



Powered Wheelchair

000690995.UK

Q100 R
Q200 R

General Manual

We at SUNRISE MEDICAL have been awarded the ISO-9001 certificate, which affirms the quality of our products at every stage, from R & D to production. This products meet the requirements in accordance with EC guidelines. Options or accessories shown are available at extra cost.



Dealer signature and stamp

QUICKSTART GUIDE

1

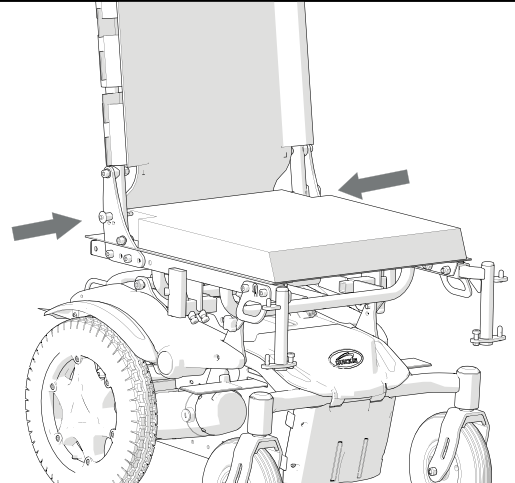
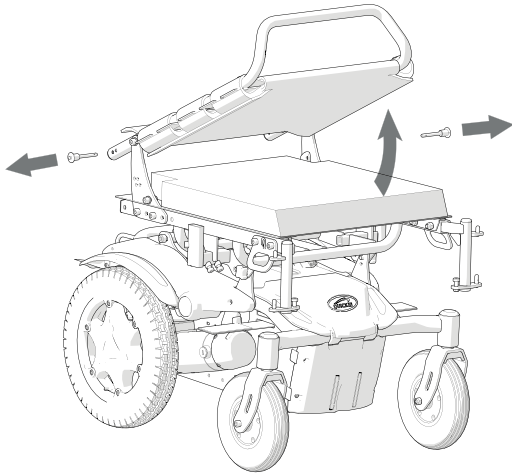

2

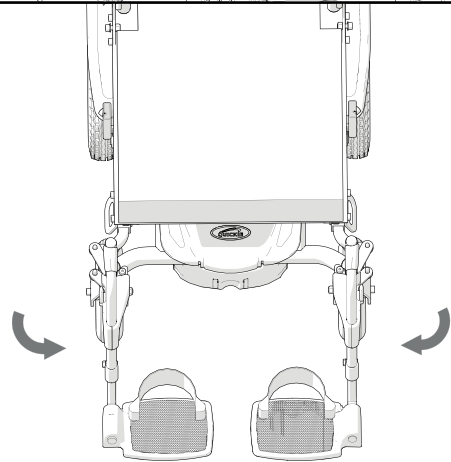
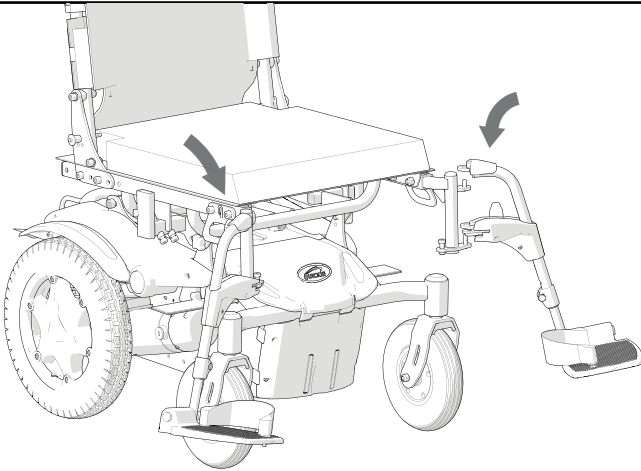

3

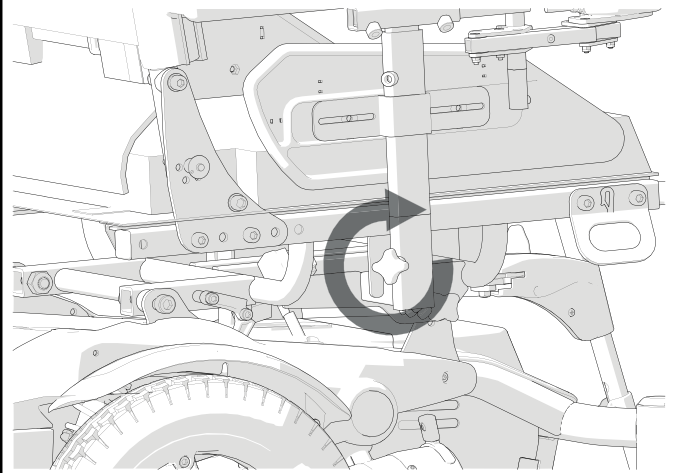
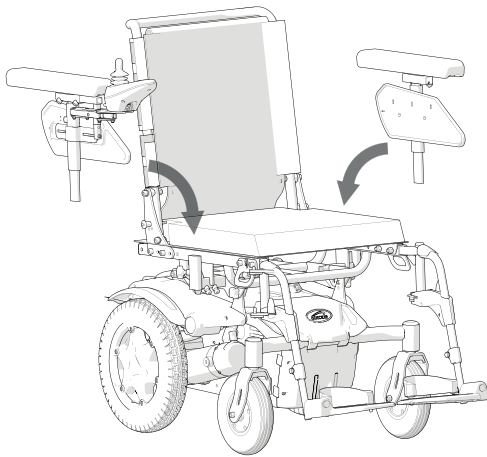

4

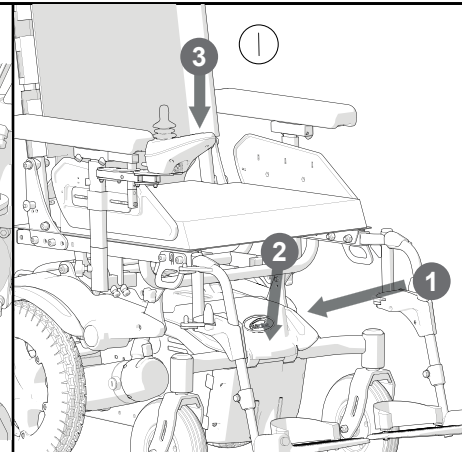
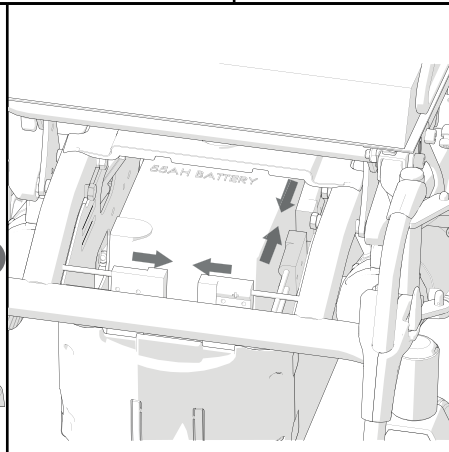
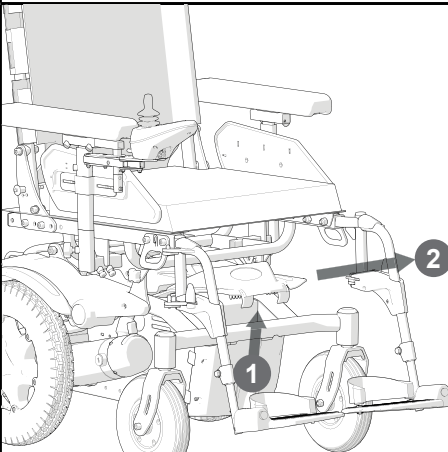

User Information

Intended use power wheel chairs:

Power wheelchairs are exclusively for a user who is unable to walk or has limited mobility, for their own personal use in- and outdoor.

When an Attendant Control Module is fitted, the Power Wheelchair may be operated by an assistant on behalf of the user.

When a Dual Control Module is fitted the Power Wheelchair may be operated by the user, or control may be switched to an assistant to operate on behalf of the user.

The maximum weight limit (includes both the user and any weight of accessories fitted to the wheelchair) is marked on the serial number label, which is affixed to the chassis of the chair.

In the chair packaging there is an additional chair serial number this can be affixed to the front page of the owners manual supplied with the wheelchair.

Warranty can only be taken on if the product is used under the specified conditions and for the intended purposes.

The intended lifetime of the wheelchair is 5 years. Please DO NOT use or fit any 3rd party components to the wheelchair unless they are officially approved by Sunrise Medical.

Area of application

The variety of fitting variants as well as the modular design mean that it can be used by those who cannot walk or have limited mobility e.g. because of:

- Paralysis
- Loss of extremity (leg amputation)
- Extremity defect deformity
- Joint contractures/joint injuries
- Strokes and brain injuries
- Neurological disabilities (e.g. MS, Parkinson...)
- Illnesses such as heart and circulation deficiencies, disturbance of equilibrium or cachexia as well as for elderly people who still have the strength in the upper body.
- Persons who are mentally and physically able to control an input device to operate the chair and its functions in a safe way.

When considering provision, please also note the body size, weight including the distribution of body weight, the user's physical and psychological constitution, the age of the user, their living conditions and their environment. If in doubt a health care professional should be involved to ensure the user is not exposed to unacceptable risks.

Sunrise Medical is ISO 9001 certified, which ensures quality at all stages of the development and production of this wheelchair.



WARNING!



DO NOT USE YOUR WHEELCHAIR UNTIL THIS MANUAL HAS BEEN READ AND UNDERSTOOD.



Sunrise Medical declares under its sole responsibility that this product is in conformity with the requirements of the directive 93/42/EEC amended by 2007/47/EEC."

Sunrise Medical declares that this product fulfils the performance requirements for a "Crash Test" to ISO 7176-19:2008.

The Serial Number and other important information may be found on a label situated on the right-hand side, main frame of the product.

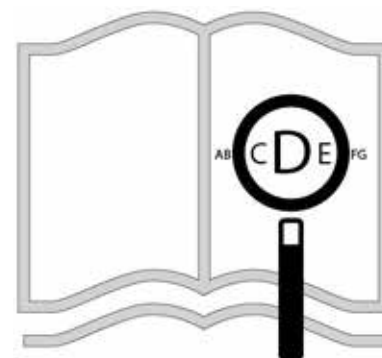

If you are visually impaired, this document can be viewed in PDF format at www.SunriseMedical.co.uk

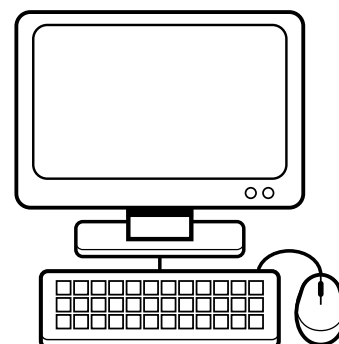

or alternatively is available on request in large text.



Q100R/Q200R Features

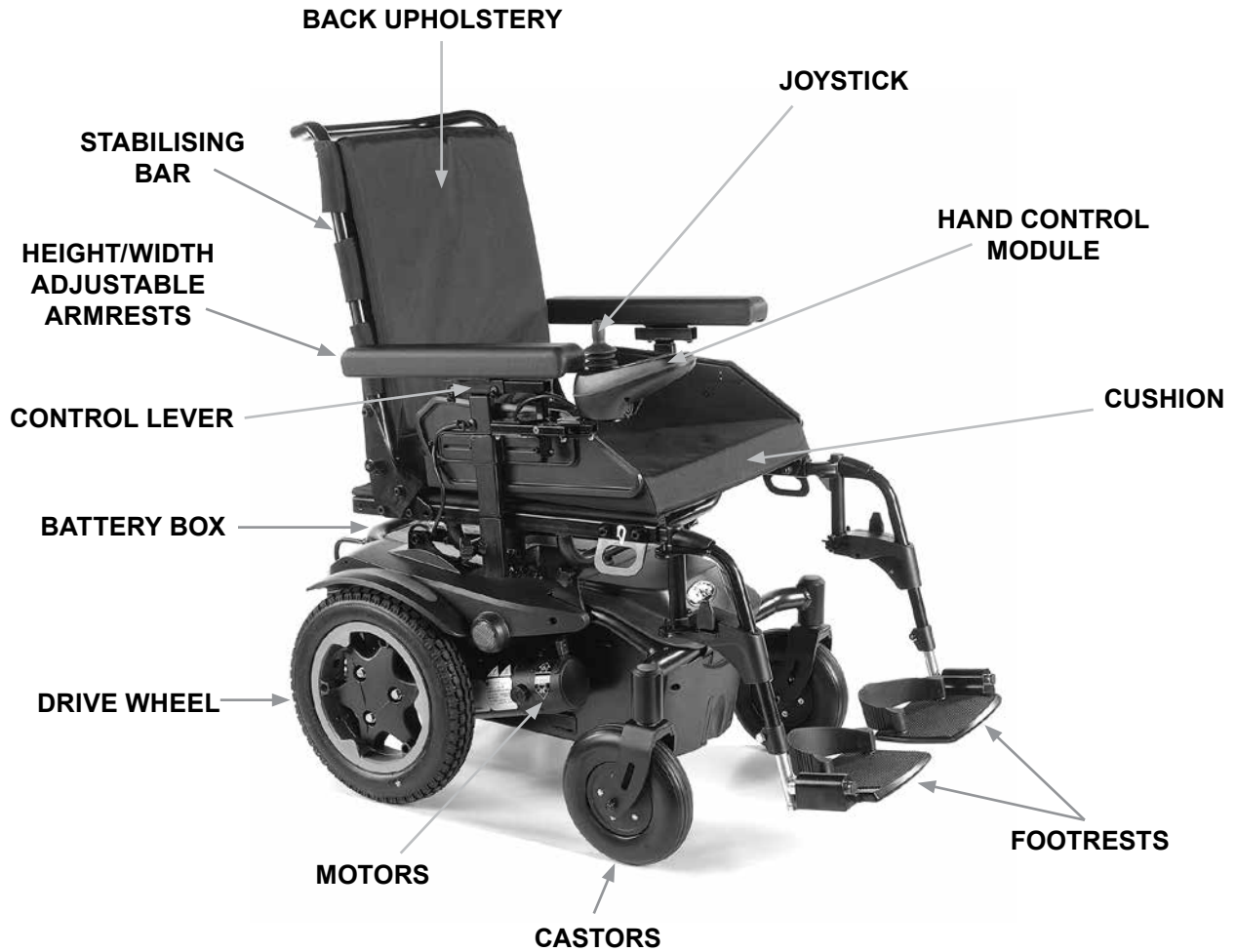

Due to its modular design, simplicity and wide range of adjustments, the Quickie Q100R/Q200R is a perfect choice for easy service, refurbishment and recycle requirements.

As a part of our ongoing product improvement initiative, Sunrise Medical reserves the right to change specifications and design without notice. Further, not all features and options offered are compatible with all configurations of the wheelchair.

All dimensions are approximate and may be subject to change.

1.0 Your Wheelchair:	7	9.0 VR2 Control System:	30
2.0 How to use this manual:	7	9.1 On/Off button:	30
2.1 Introduction:	7	9.2 Battery Level Indicator:	30
2.2 Guarantee	8	9.3 Locking/unlocking the wheelchair:	30
3.0 Label Explantation / Word definitions:	9	9.4 Operating the control joystick:	31
3.1 Definitions of words used in this manual:.....	9	9.5 Maximum speed/profile indicator:	31
4.0 Safety:	11	9.6 The horn button:	31
4.1 General Warnings:	11	9.7 Speed/Profile decrease button:	31
4.2 Features and options:	11	9.8 Speed/Profile increase button:	31
4.3 Preliminary checks:	11	9.9 VR2-L	32
4.4 Emergency braking:	11	9.10 Charging and programming socket:	33
4.5 Kerbs, (Fig 4.1):	11	9.11 VR2 dual control unit:	33
4.6 Tyres:	12	9.12 Control button and indicator:	33
4.7 Freewheel device, (Fig.4.2):	12	9.13 Actuator button and LED:	33
5.0 Transportation	13	9.14 Maximum speed button and indicator:	34
5.1 Transport of the wheelchair in a car	13	10.0 Troubleshooting The VR2 Hand Control:	34
5.2 The wheelchair as a passenger seat	15	11.0 Batteries and Charging:	36
5.3 Special transport requirements	17	11.1. Battery & Charger Specification:	36
5.4 General transport warnings	17	11.2 Electrical fuses:	36
6.0 Maintenance & cleaning	18	11.3 Batteries:	36
6.1 Maintenance	18	11.4 General battery information:	38
6.2 Sharp turns:	19	11.5 Maintenance-free batteries:	38
6.3 Weight limit:	19	11.6 Battery care:	38
6.4 Hot surfaces:	19	11.7 Maintenance-free battery care plan:	38
6.5 Road caution:	19	11.8 General charger information:	39
6.6 Adverse conditions:	19	11.9 Charger Specification:	39
6.7 Ramps:	19	11.10 Charger safety features:	39
6.8 Transfer to and from the chair:	19	11.11 Procedure for connecting the charger and charging: ...	39
6.9 Anti tips:	19	11.12 Charger safety and caution notes:	39
6.10 Use on a slope:	20	11.13 The range of your vehicle:	40
6.11 Gradients: ascents:	20	11.14 Common battery statements:	40
6.12 Gradients: descents:	20	12.0 Adjustments:	41
6.13 Lap belt:	20	12.1 Adjustment of the footrest:	41
6.14 Rear View Mirror:	22	12.2 Inner Or Outer Width Adjustment of the footrests:	41
7.0 Assembly:	23	12.3 Adjustment of the armrests:	41
7.1. Footrest	23	12.4 Seat width adjustment:	41
7.2. Armrest	23	12.5 Seat Centre of Gravity Adjustment:	41
7.3. Anti-tip wheels	23	12.6 Seat depth adjustments:	42
7.4. Kerb climber	23	12.7 Control Adjustment:	42
7.5. Batteries	24	12.8 Dual/Attendant control (Where fitted)	42
7.6. Wheels	24	12.9 Parallel swing-away control:	42
7.7. Fitting The Lap Belt :	25	12.10 Programming:	42
7.8 Crutch Holder	25	13.0 Cleaning:	43
7.9 Lights and indicators	25	13.1 Cleaning General:	43
8.0 Using The Wheelchair:	26	13.2 Cleaning seating:	43
8.1 Preparing for stowed transportation:	26	13.3 Cleaning control system:	43
8.2 To use the wheelchair again:	26	13.4 Speciality controls:	43
8.3 Mechanical Fixed Reclining back (90° to 102° - 4 positions)	26	14.0 Shipping & Storage Requirements:	43
8.4 Fixed Seat Tilt:	27	14.1 Storage temperature & humidity:	43
8.5 Freewheel device:	27	14.2 Special shipping requirements:	43
8.6. Tyre pressure:	27	14.3 Medium to long term storage:	43
8.7 Transfers :	28	15.0 Disposal:	43
8.8 Slopes:	28	16.0 Specification sheets (EN 12184 & ISO 7176-15)	44
8.9 Laterals	29	17.0 Service Advice-Service History:	46
8.10 Mounting a kerb or step:	29	18.0 Performance checks:	47
8.11 Dismounting the kerb:	29	18.1 Re-use	47

1.0 Your Wheelchair:

We at Sunrise Medical want you to get the best out of your Q100R/Q200R wheelchair. This Owner's Manual will familiarise you with the chair and its features. It contains hints on everyday usage and general care in addition to information on the high quality standards which we adhere to and details about the guarantee.

Your wheelchair will be delivered ready for quick assembly – refer to the quick start guide on the inside cover of this user manual. There are a wide range of components and adjustments available on the Q100R/Q200R. For further information about these you should contact your Sunrise Medical authorised dealer.

Your wheelchair will reach you in excellent condition having been personally inspected before leaving our factory. Following the guidelines for maintenance and cleaning your wheelchair will maintain its first class condition and give you complete satisfaction.

The Q100R/Q200R has been designed for use by an individual on a daily basis. It is suitable for both indoor and outdoor use (Class B). It is only intended for use as a pavement vehicle, but may also be used when crossing between pavements.

This vehicle has been designed for a single occupant of limited mobility up to the weight of Q100R 125Kg and Q200R 136Kg (dependant on options chosen for your chair) who has the cognitive, physical and visual ability to control the vehicle safely on a maximum slope – see section 16.0 Specification Sheet section for maximum slope details. If you are in any doubt as to the suitability of the power chair, contact your local Sunrise Medical approved supplier for clarification, prior to commencing use.

It is very important to read the relevant section of the owner's manual when making any minor adjustments. Consult the Technical Manual or your local Sunrise Medical authorised dealer for more complex adjustments.

If you have any queries about the use, maintenance or safety of your wheelchair, please contact your local approved Sunrise Medical service agent. If you do not know of an approved dealer in your area or have any other questions please write or telephone:

Sunrise Medical
Thorns Road
Brierley Hill
West Midlands
DY5 2LD
England
Phone: 0845 605 66 88
Fax: 0845 605 66 89
www.SunriseMedical.co.uk

2.0 How to use this manual:

2.1 Introduction:

Please keep a note of your local service agent's address and telephone number in the space below.

In the event of a breakdown, contact them and try to give all relevant details so they can help you quickly.

The wheelchairs shown and described in this manual may not be exactly the same in every detail as your own model. However, all instructions are still entirely relevant, irrespective of detail differences.

NOTE: The manufacturer reserves the right to alter without notice any weights, measurements or other technical data shown in this manual. All figures, measurements and capacities shown in this manual are approximate and do not constitute specifications.

2.2 Guarantee

THIS GUARANTEE DOES NOT AFFECT YOUR LEGAL RIGHTS IN ANY WAY.

Sunrise Medical* provides a guarantee, as set out in the warranty conditions, for products to its customers covering the following.

Warranty conditions:

1. Should a part or parts of the product require repair or replacement as a result of a manufacturing and/or material fault within 24 months, then the affected part or parts will be repaired or replaced free of charge. The warranty will only cover manufacturing defects
2. To enforce the warranty, please contact Sunrise Medical Customer Service with the exact details of the nature of the difficulty. Should you be using the product outside the area covered by the Sunrise Medical customer service agent, repairs or replacement will be carried out by another agency as designated by the manufacturer. The product must be repaired by a Sunrise Medical designated Customer Service agent, (dealer).
3. For parts, which have been repaired or exchanged within the scope of this warranty, we provide a warranty in accordance with these warranty conditions for the remaining warranty period for the product in accordance with point 1.
4. For original spare parts which have been fitted at the customer's expense, these will have a 12 months guarantee, (following the fitting), in accordance with these warranty conditions.
5. Claims from this warranty shall not arise, if a repair or replacement of a product or a part is required for the following reasons:
 - a. Normal wear and tear, which include but is not limited to the following parts where fitted; batteries, armrest pads, upholstery, tyres, brakes shoes, ferrules, etc.
 - b. Any overloading of the product, please check the EC label for maximum user weight.
 - c. The product or part has not been maintained or serviced in accordance with the manufacturer's recommendations as shown in the user instructions and/or the service instructions.
 - d. Accessories have been used which are not specified as original accessories.
 - e. The product or part having been damaged by neglect, accident or improper use.
 - f. Changes/modifications have been made to the product or parts, which deviate from the manufacturer's specifications.
 - g. Repairs have been carried out, before our Customer Service has been informed of the circumstances.
6. This guarantee is subject to the law of the country in which the product was purchased from Sunrise Medical⁶





* Means the Sunrise Medical facility from which the product was purchased.

Additional Notes For Australia Only:

- i. For goods provided by Sunrise medical Pty Ltd in Australia, our goods come with a guarantee by Sunrise Medical that cannot be excluded under Australian Consumer Law.
- ii. You are entitled to a replacement or refund for a major failure and for compensation for any foreseeable loss or damage.
- iii. You are also entitled to have the goods repaired or replaced if the goods fail to be of acceptable quality and the failure does not amount to a major failure.
- iv. The benefits to you given by this warranty are in addition to your other rights and remedies under a law in relation to the goods to which the warranty relates.

3.0 Label Explanation / Word definitions:

3.1 Definitions of words used in this manual:

Word	Definition
 DANGER!	Advice to the user of Potential Risk of serious injury or death if the advice is not followed
 WARNING!	Advice to the user of a potential risk of injury if the advice is not followed
 CAUTION!	Advice to user that potential damage to equipment may occur if the advice is not followed
NOTE:	General advice or best practice
RWD	Rear Wheel Drive
	Reference To Additional Documentation

4.0 Safety:

If you follow the instructions given in this manual, you will enjoy many trouble-free years of use:

WARNING!

- This vehicle is not designed for use on the road except for crossing from one kerb to another.
- Load data always refers to one single person as operator.
- The wheelchair is authorised for use by one person or one seated person and their attendant if using a Dual or Attendant control unit.

WARNINGS!

4.1 General Warnings:

- Always ensure that your wheelchair is switched off before attempting to mount or dismount.
- Always ensure that you are able to operate all controls from a comfortable position. Paying attention to your posture is essential to ensure your continued comfort and well being.
- Always make sure that you can be seen clearly, especially if you intend using your wheelchair in poor light.
- This wheelchair has been built to match the needs of a particular user. If used by another user then it may need to be adjusted and reprogrammed.
- Do not let children or others use your wheelchair.
- Do not lift or hoist the wheelchair by any detachable parts such as leg rests, arm rests etc.

CAUTION!

4.2 Features and options:

Some of the options shown in this manual may not be available in your country and may also restrict the overall physical limits of the standard product (e.g. max. speed, user weight limit, etc.). Those limitations are marked on the order form, in the technical manual and in this owner's manual.

For further information please consult your Sunrise Medical authorised dealer.

WARNING!

CHOKING HAZARD – This mobility aid uses small parts which under certain circumstances may present a choking hazard to young children.

DANGER!

4.3 Preliminary checks:

- You should not try to manoeuvre at full speed.
- If you have to make a sudden turn, slow down first using the joystick or the speed control knob.
- This is very important if you are going down a hill.
- Lack of attention to this point may result in your overturning the wheelchair.
- Always check that the wheelchair is switched off before trying to get in or out.
- Always check that you can operate all the controls from a comfortable seated position. It is essential to pay attention to posture in order to assure comfort and well-being.
- Always check that the freewheel device is switched off before setting the chair in motion.
- Always check that you can be seen clearly, especially if you are using the wheelchair in conditions of low visibility.

WARNING!

4.4 Emergency braking:

If power is cut by means of the ON/OFF button, braking will be immediate and total. This method of stopping is not recommended except for emergencies, since the stop will be extremely sudden.

4.5 Kerbs, (Fig 4.1):

- Always cross the road as rapidly as possible, since other vehicles may appear.
- Do not attempt to climb or to descend from, a kerb of more than 100 mm. height.
- Do not attempt to ascend high kerbs, steep slopes or cambers due to the risk of falling out of the chair or tipping over.
- Do not attempt to ascend any kerb in the vicinity of a drain cover, uneven surfaces, or gravel covering.
- Do not attempt to descend a kerb of more than 50 mm in forward position.
- Do not attempt to climb or descend any kerb at an oblique angle. Approach only at an angle of 90° with at least 500mm run-up.

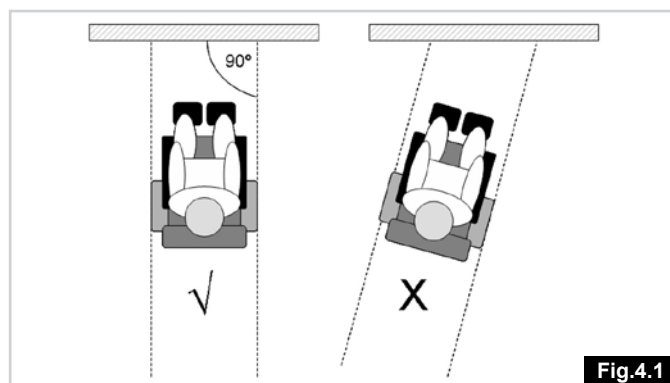

Fig.4.1

4.6 Tyres:

The tyres of a wheelchair suffer wear depending on how much the chair is used. Check them regularly, especially for inflation pressure, according to the service instructions in this manual.

WARNING!

Where fitted NEVER inflate pneumatic tyres with the air hose of a service station.

WARNING!

4.7 Freewheel device, (Fig.4.2):

Also see Fig.3.1

- Only use this function to push the chair manually from one spot to another.
- Keep in mind that while the freewheel system is in operation, the chair is without a braking system.
- Disengaging the motor causes an error message to appear in the control, which is indicated when the LED display flashes rapidly.
- For safety reasons the wheelchair can no longer be moved using the joystick.
- Do not operate the freewheel device whilst seated in the wheelchair.
- The freewheel device should only be operated by a person who has the strength and agility to be able to fully manoeuvre the wheelchair safely, during freewheel.

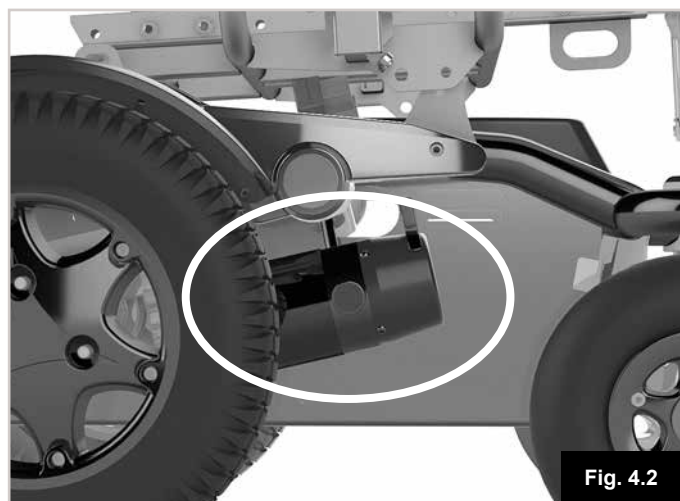

Fig. 4.2

5.0 Transportation

5.1 Transport of the wheelchair in a car

Getting in and out of the vehicle

⚠ DANGER!

- Confirm that the vehicle is suitably equipped to transport a passenger in a wheelchair, and ensure the method of access/egress is suitable for your wheelchair type. The vehicle should have the floor strength to take the combined weight of the occupant, the wheelchair and accessories.
- Use a ramp (or lifting device) suitable for the entire weight of the wheelchair (including user) for entering the vehicle.
- The wheelchair should be secured in a forward facing direction. This wheelchair is approved for use in cars and meets the requirements for forward facing transport and head on collisions. The wheelchair has not been tested for other positions in a vehicle (Fig. 5.1).

⚠ CAUTION!

- Sufficient space should be available around the wheelchair to enable clear access to attach, tighten and release the wheelchair and occupant tie down restraints and safety belts.
- Ease of access to, and manoeuvrability in, motor vehicles can be significantly affected by wheelchair size and turning radius; smaller wheelchairs and/ or wheelchairs with a shorter turning radius will generally provide greater ease of vehicle access and manoeuvrability to a forward-facing position.

Securing the wheelchair with a strap restraint system

This wheelchair has been successfully crash tested in accordance to: ISO 7176-19:2008, using a representing restraint system.

- Secured with a 4-point strap restraint system (2 in the front, 2 in the back, Fig.5.2), that conforms to:
 - i. ISO 10542 (international) or
 - ii. SAE J2249 (USA).

NOTE: Wheelchair secured with a 4-point strap restraint system; suitable for the total weight of the wheelchair (including any options) in accordance with the WTORS1) manufacturers instruction.

Terminology explained:

1) *WTORS: Wheelchair Tie-down Occupant Restraint System*

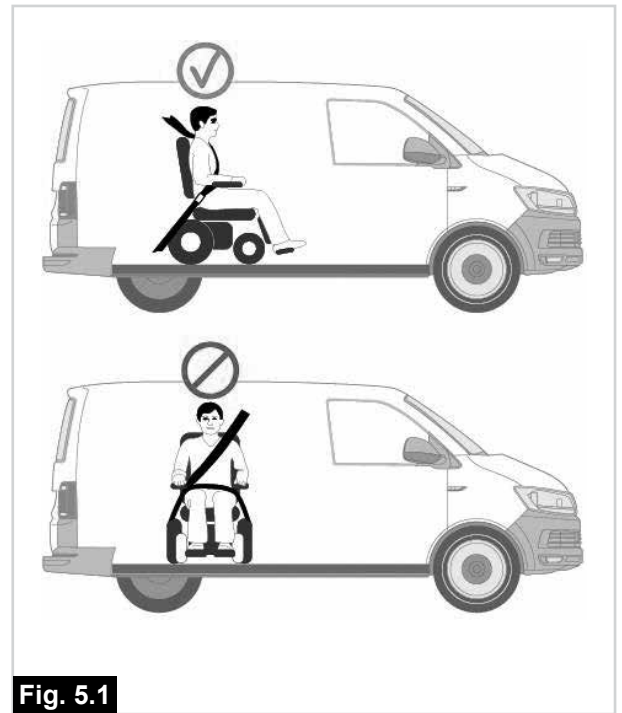

Fig. 5.1

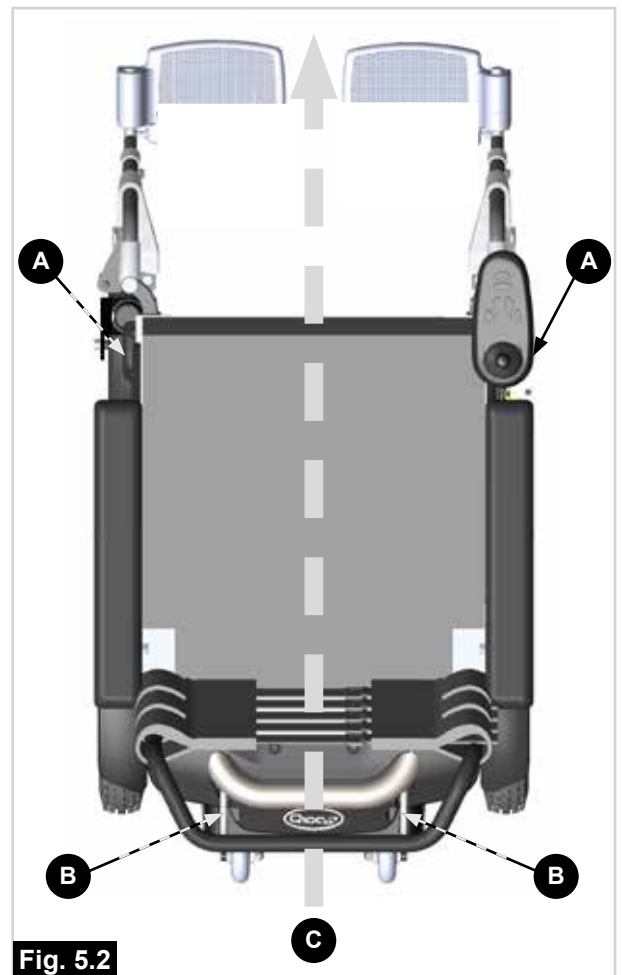

Fig. 5.2

- A** Front Tie Down Points.
- B** Rear Tie Down Points.
- C** Direction of Travel.

⚠ DANGER!

- The wheelchair can only be secured by using the tie-down points on the wheelchair's frame (Fig. 5.2 - 5.8).
- The tie-down points (2 in the front, 2 in the back) are indicated by the tie-down symbol (Fig. 5.5). Fit the front straps first, then the rear. Tension the straps to secure the wheelchair. The wheelchair may not be secured onto any accessories (wishbones, armrests, anti-tip brackets etc.).
- No changes or replacements must be made to the anchorage points/car fastenings on the wheelchair, or to constructional elements or parts of the frame without consulting the manufacturer.
- When the wheelchair is transported in a vehicle without occupant and no restraint system is available then the wheelchair should be properly stored and secured in the cargo area during travel.

Fig. 5.5

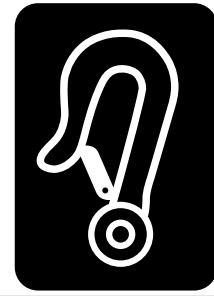

Fig. 5.6



Fig. 5.3

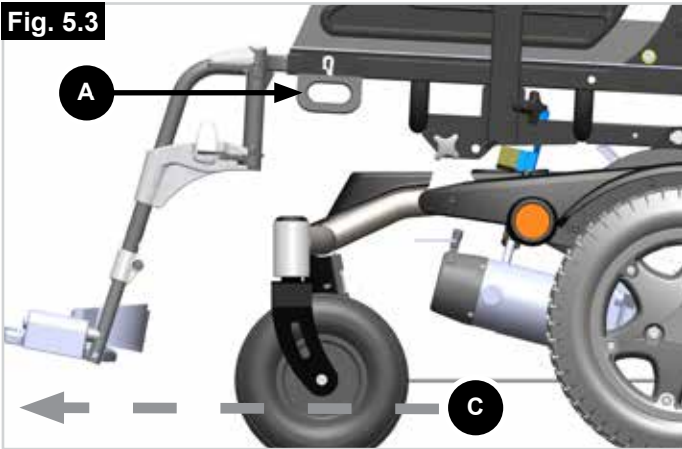

Fig. 5.4

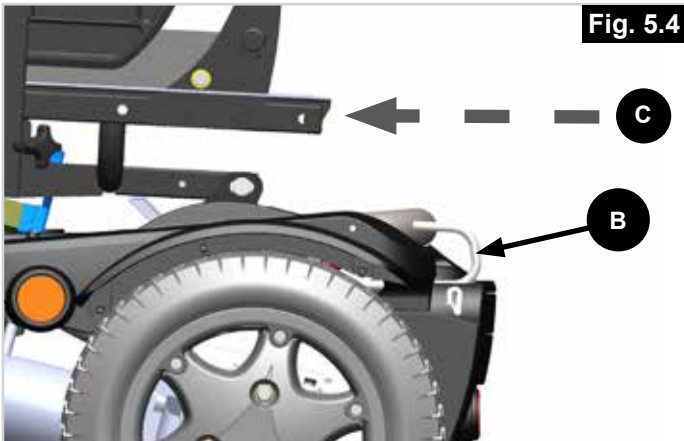
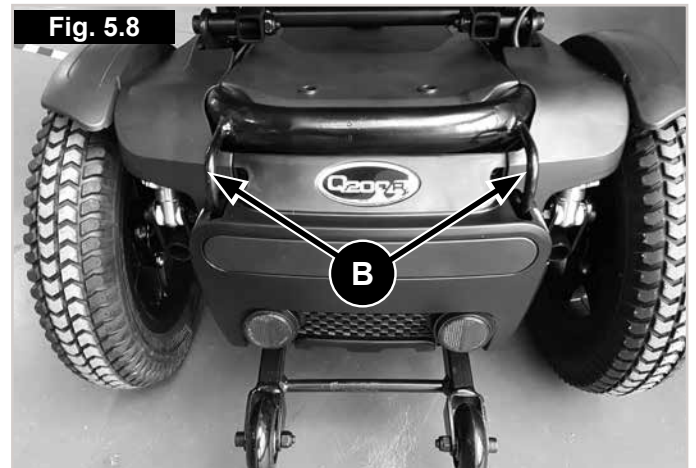

Fig. 5.7



Position of the Front tie down restraint., (Fig.5.7 - A).

Fig. 5.8



Position of the Rear tie down label & bracket, (Fig.5.8 - B).

- A** Front Tie Down Points.
- B** Rear Tie Down Points.
- C** Direction of Travel.

5.2 The wheelchair as a passenger seat

A wheelchair secured in a vehicle will not provide the equivalent level of safety and security as a vehicle seating system. Sunrise Medical recommends that the user transfers to the vehicle seating and uses the vehicle-installed restraint system wherever possible. Sunrise Medical recognizes that it is not always practical for the user to be transferred and in these circumstances, where the user must be transported whilst in the wheelchair, the following advice must be followed:

DANGER!

- The safety of the user during transportation depends upon the diligence of the person securing the tie down restraints and they should have received appropriate instructions and/or training in their use.
- Wherever possible remove and stow safely away from the wheelchair all auxiliary equipment, e.g. : crutches, loose cushions, tray tables, etc.
 - i. Removed and secured separately in the vehicle, or
 - ii. Secured to the wheelchair, but with energy-absorbing padding placed between the table and the user.
- Articulating/elevating leg rest should not be used in the elevated position when the wheelchair and user are being transported.
- If applicable: Reclining backrests should be returned to an upright position.
- If applicable: Seat elevators should be in the lowest position.
- If applicable: The manual brakes must be firmly applied.

Occupant restraint Instruction

DANGER!

- Use a 3-point occupant restraint system to secure the occupant.
- Both pelvic and upper torso restraint belts must be used to restrain the occupant (Fig. 5.5) to reduce the possibility of head and chest impacts with the vehicle components.
- Restraints should be mounted to the appropriate vehicle pillar and should not be held away from the body by wheelchair components such as armrest or wheels (Fig. 5.7).
- Use a suitable positioned headrest when being transported in a wheelchair.
- Postural supports (lap straps, lap belts) should not be used or relied on for occupant restraint in a moving vehicle unless they are labelled as meeting the requirements specified in ISO 7176-19:2008 or SAE J2249.

Positioning the occupant restraint

DANGER!

- The pelvic restraint belt must be worn low across the front of the pelvis so that the angle of the pelvic belt is within the preferred zone of 30° to 75° to the horizontal.
- A steeper (greater) angle within the preferred zone is desirable i.e. closer to, but never exceeding 75° degrees (Fig. 5.10).
 - i. The upper torso restraint belt must fit over the shoulder and across the chest as illustrated (Fig. 5.9). Restraint belts must be adjusted as tightly as possible consistent with user comfort.
- Restraint belt webbing must not be twisted when in use.
- Care should be taken when applying the occupant restraint to position the seatbelt buckle so that the release button will not be contacted by wheelchair components during a crash.

Passenger with a user weight < 22 kg.

When the user being transported is a child, less than 22 kg mass and the vehicle involved has less than eight (8) seated passengers it is recommended that they be transferred to an UNCE Regulation 44 compliant child restraint system (CRS).

This type of restraint system provides a more effective occupant restraint system than the conventional 3 point occupant restraint system and some CRS systems also include additional postural supports to assist in maintaining the position of the child when seated.

Parents or care providers may consider the option, in some circumstances, for their child is to remain in their wheelchair whilst in transport due to the level of posture control and comfort provided by the set up in the wheelchair.

We would recommend in such circumstances that a risk assessment be carried out by your healthcare professional and relevant competent persons.

Fig. 5.9

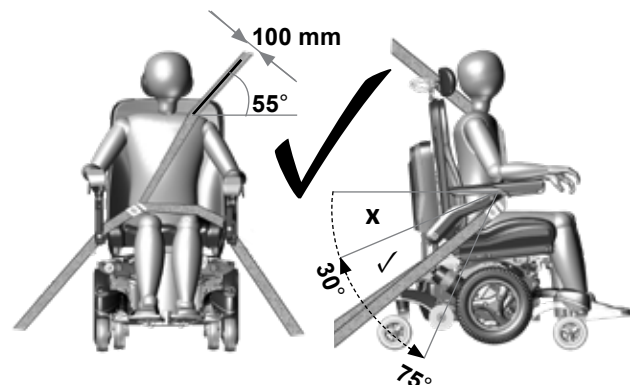
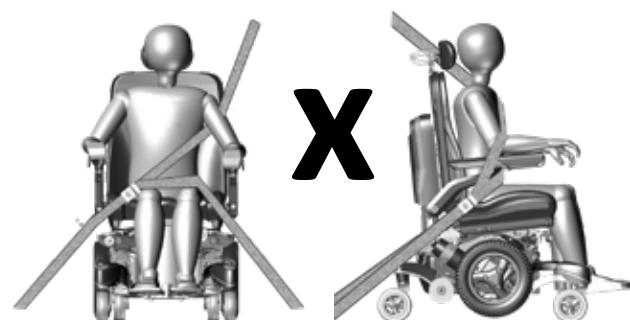

Fig. 5.10



5.3 Special transport requirements

Using your wheelchair on the train.

Before you travel, please contact the train operator. They will be able to supply details of any special requirements/instructions. We advise you to check the following:

- Is there a suitable and intended “wheelchair” area in the train for wheelchair users (with adequate turning space to manoeuvre)?
- Is there a suitable or designated area on the platform for wheelchair users (with adequate turning space to manoeuvre)?
- Is there suitable boarding access available to allow you to access the railway carriage and the intended “wheelchair” area?
- Is the boarding access suitable for the combined mass of the wheelchair and the occupant?
- Make sure the slope of the boarding access is not greater than the dynamic safe slope. (See Section 16)
- Any obstacles or thresholds should not exceed the max kerb climbing capability of your wheelchair. (See Section 16)

Most train operators will provide assistance provided that arrangements have been made in advance. We suggest you have your Owner’s Manual ready when planning your journey and contacted them.

Transporting the wheelchair as luggage.

Parts of the wheelchair that can easily be detached should be removed when transporting the wheelchair. Store these parts securely. E.g.:

- A. Remove the leg rests
 - B. Remove the armrests
 - C. Fold down the backrest
- Ensure that any detachable parts are secured with your mobility aid or separately packed and labelled so they do not get lost during loading and unloading.
 - The wheelchair may be transported by road, rail, sea or air.
 - Before you travel, please contact the appropriate carrier. The travel operator will be able to supply details of any special requirements/instructions.
 - For information about dimensions and weight of the wheelchair, see (Section 16).
 - For information about the batteries in your wheelchair see (Section 6).
 - Ensure that any detachable parts are secured with your mobility aid or separately packed and labelled so they do not get lost during loading and unloading.

- Take this user manual, the seating system user manual (& Seating System) and the controller user manual (& Controller) with you. The carrier will need to refer to the following sections:
 - i. Pushing the wheelchair.
 - ii. How to lock/unlock the controller.
 - iii. How to disconnect the batteries.
 - iv. How to disconnect the drive.
- Transporting the chair.
- Medium to long term storage, follow the instructions.

Hoisting the wheelchair (Fig. 5.11)

The most forward seat depth holes provide a reference balance position for 2 point lifting systems (individual chair configuration and options may require alternative position).



5.4 General transport warnings

WARNING!

- No changes or replacements must be made to the anchorage points/car fastenings on the wheelchair, or to constructional elements or parts of the frame without consulting Sunrise Medical.
- The wheelchair should be inspected by a Sunrise Medical authorised dealer/service agent, before reuse following involvement in any type of vehicle collision.

6.0 Maintenance & cleaning

The wheelchair's lifespan is dependent on it being well maintained.

For information concerning specific settings, maintenance or repair work, please contact your authorized Sunrise dealer. Always be sure to mention the model, year of manufacture and identification number provided on the identification plate of the wheelchair when contacting your dealer.

CAUTION!

The wheelchair should be serviced by your authorized Sunrise dealer once a year or, in the case of intensive use, every six months. For a list of approved authorised dealers in your area please contact Sunrise Medical Service Centre.

The contact details of your local Sunrise medical service centre can be found on the inside front cover of this booklet.

National and International Website addresses are on the back cover.

6.1 Maintenance

WARNING!

- Loose fasteners should be re-tightened according to the installation instructions.
- Chest straps should be replaced at the first indication of damage and/or excessive wear.
- If a broken or loose component is found, discontinue use immediately and contact your authorised Sunrise Medical supplier for replacement.
- Check all Velcro fastening straps for correct adhesion when pressed together.
- Ensure that any contamination, such as fluff, hair, etc is removed from the Velcro straps. Such contamination may affect adhesion.

WARNING!

- If you are in any doubt about the performance requirements of your wheelchair contact your Sunrise Medical authorised dealer.
- After performing any maintenance or repairs on the wheelchair you must make sure that it is functioning correctly before it is used.
- All fasteners must be replaced like for like using the correct length, tensile strength and materials.
- When replacing self-locking nuts, or nuts/studs secured with a thread locking solution, ensure that a suitable thread locking solution is reapplied to the fastener.

Daily checks

Perform the daily check routine before driving as described in chapter 18.0.

Weekly checks

Perform the weekly check routine before driving as described below.

Checking Parking brake:

This test should be carried out on a level floor with at least one meter clearance all around the chair.

- Switch on the control system.
- Check that the battery gauge remains on, or flashes slowly, after one second.
- Push the joystick slowly forwards until you hear the parking brakes operate.
- The chair may start to move.
- Immediately release the joystick. You must be able to hear each parking brake operate, (click), within a few seconds.
- Repeat the test a further 3 times, pushing the joystick slowly backwards, left and right.

Checking connectors & cables:

- Make sure that all connectors are securely mated.
- Check the condition of all cables and connectors for damage.

 **DANGER!**

6.2 Sharp turns:

Full speed turns should not be attempted. If you need to turn sharply you must reduce your speed with the joystick or speed setting. This is particularly important when travelling across or down a slope. Disregarding this advice could lead to your wheelchair tipping over.

 **DANGER!**

6.3 Weight limit:

- For Q100R The user plus items carried should never exceed a total weight of 125 kgs.
- For Q200R The user plus items carried should never exceed a total weight of 136 kgs.
- Never use this chair for weight training if the total weight (user plus additional weights) exceed a total weight as listed above.
- Exceeding the weight limit is likely to damage the seat, frame or fasteners and may cause severe injury to you or others from chair failure
- Exceeding the weight limit will void the warranty
Wheelchair motors:

6.4 Hot surfaces:

 **WARNING!**

After prolonged use, the motors will produce heat, which is radiated through the motors' outer casing. Do not touch the motors' outer casing for at least 30 minutes after using the wheelchair, to allow it to cool.

 **WARNING!**

Not only motors can become hot during the operation of the chair, the upholstery material and armrests may heat up when standing in the sun.

 **DANGER!**

6.5 Road caution:

- Please show the utmost consideration for the other traffic on the road.
- Remember that the last thing a car or lorry driver expects to see is a wheelchair backing off the kerb into the road.
- If in any doubt, do not risk crossing the road until you are certain that it is safe.
- Always cross the road as quickly as possible; there may be other traffic.

 **WARNING!**

6.6 Adverse conditions:

- Please be aware that when driving your wheelchair in adverse conditions, e.g. on wet grass, mud, ice, snow or other slippery surfaces, you may experience a reduction in the grip and traction of your wheelchair. We recommend you take extra precautions in these conditions, particularly on hills and slopes; your wheelchair could become unstable or skid causing possible injury. Extreme variances in temperature may trigger the self protect mechanism in the control system. If this occurs the control system will temporarily shut down to prevent damage to the electronics or the chair.
- When you are using a Powered Scooter or Wheelchair, take extra care with loose or long items of clothing. Moving parts, such as wheels, can be potentially dangerous or even fatal if clothing becomes entangled.

 **WARNING!**

6.7 Ramps:

- When using a ramp, please ensure that it is capable of taking the combined weight of the power chair and yourself.
- If a ramp is being used to load a chair into a vehicle, please ensure the ramp is properly secured to the vehicle.
- Always approach the ramp head-on and exercise caution.
- Please ensure your ramp is suitable for the product you are transporting.

 **WARNING!**

Maximum ramp angle is defined in Section 16 Specification Sheets

6.8 Transfer to and from the chair:

Sunrise Medical recommend that you consult your healthcare professional for assistance in developing your personal front or side transfer technique to best suit your needs and avoid any personal injury.

 **WARNING!**

6.9 Anti tips:

- Make sure that anti tips are not damaged or worn before using your chair.
- Check the anti tips are functioning correctly on a regular basis.
- Attendants must be aware of the location of the anti tips to prevent feet being trapped underneath causing injury.
- Attendants - Do not stand on the anti tips, this could cause the wheelchair to become unstable.

⚠ WARNING!

6.10 Use on a slope:

Your wheelchair has been designed and tested to allow its use on slopes or gradients as defined in Section 16 Specification Sheets.

- Before attempting to climb or descend a slope or a kerb, caution should be taken when using weight shift options (e.g. powered recline) of the seat where fitted and/or your body for a counter balance weight.
- To improve stability lean forward when driving uphill, with the seat and back in an upright position.
- Alternatively sit in an upright position when travelling in a forward, downhill direction or recline the seat backwards. We strongly recommend that you return back to an upright lowered position before attempting to climb or descend a slope.
- Failure to do this may cause the wheelchair to become unstable.
- If you are in any doubt about the capabilities of your wheelchair on a slope then do not attempt to drive up or down the slope/kerb; try to find an alternative route.

⚠ WARNING!

6.11 Gradients: ascents:

- When going uphill, keep the chair moving.
- Steer by moving the joystick from side to side.
- If you have stopped on a hill, you should start slowly.
- On a RWD chair, if necessary lean forward to prevent the tendency for the front wheels to lift.

⚠ WARNING!

6.12 Gradients: descents:

- On descents, it is important not to let the wheelchair accelerate beyond its normal level of ground speed.
- It is safer to proceed slowly down steep descents (below the speed of 5kph) and stop, if any anxiety arises regarding directional control.
- If the chair picks up speed, centre the control to slow it or to stop all forward movement, then restart slowly and do not allow the speed to increase.

⚠ WARNING!

6.13 Lap belt:

Before using your wheelchair ensure the Lap belt is worn and correctly adjusted before use.

The lap belt is fitted to the wheelchair as shown in the fitting instructions in section 5.7. It is important that the belt is secured around the back of the wheelchair. The straps can be fed between the armrest and backrest. Adjust the belt position so that the buckles are in the centre of the seat. See section 5.7.

Adjust the lap belt to suit the user's needs as follows:

To increase the belt length:

Feed the belt through slide adjusters and male buckle to provide more belt length, (Fig.6.1).

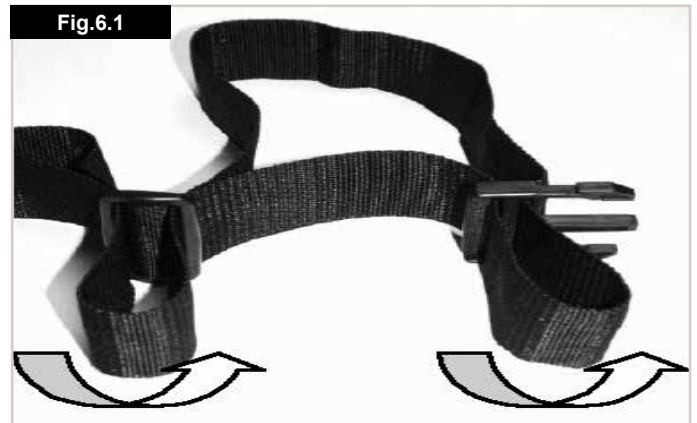

To reduce the belt length:

Feed the belt back through male buckle and slide adjusters, (Fig.6.2).

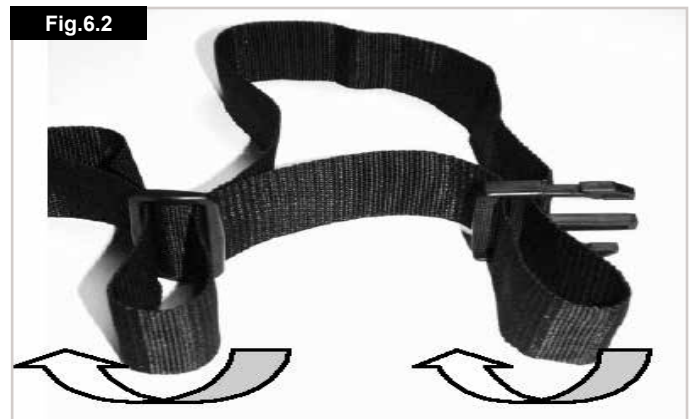

Ensure that there is no excess belt material looping out of the male buckle, (Fig.6.3)



When fastened check space between the lap belt and the user, when correctly adjusted it should be possible to insert the flat of the hand between the lap belt and the user, (Fig.6.4).



Generally the Lap Belt should be fixed so that the straps sit at an angle of approximately 45°, and when correctly adjusted should not allow user to slip down in the seat, (Fig.6.5).



To fasten buckle:

Firmly push the male buckle into female buckle, (Fig.6.6).

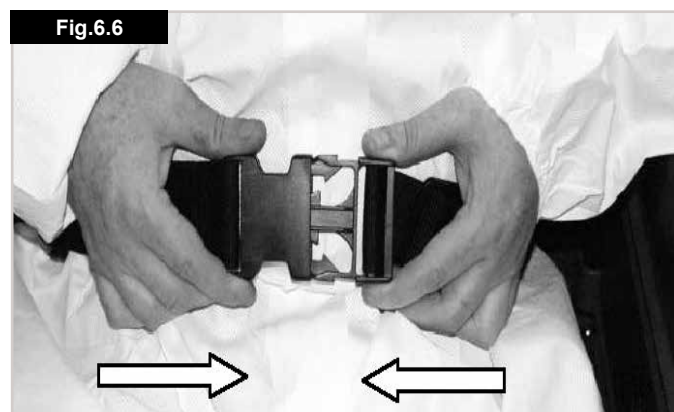

To release belt:

Press the exposed sides of the male buckle and push towards the centre whilst gently pulling apart, (Fig.6.7).

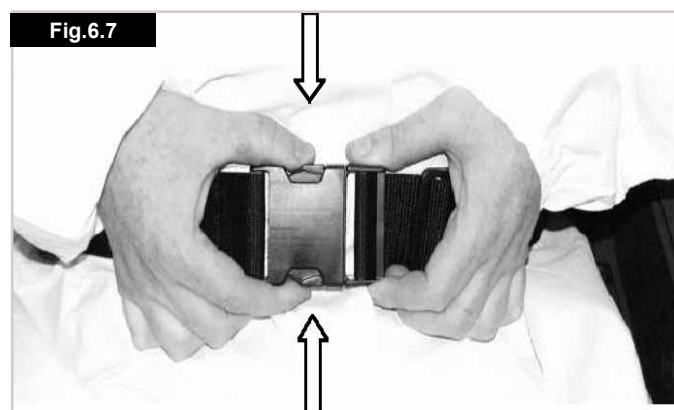

⚠ WARNING!

Do not rely on the lap belt only when the wheelchair and occupant are transported in a vehicle, use the separate occupant lap and diagonal restraints provided in the vehicle.

⚠ WARNING!

Advice to Client

The lap belt must be checked on a daily basis to ensure it is adjusted correctly and it is free from any obstruction or adverse wear.

⚠ DANGER!

Failure to make sure that the lap belt is secure and adjusted prior to use could cause serious injury to the user. E.g. too loose a strap may allow the user to slip down in the chair and risk suffocation.

⚠ WARNING!

Maintenance:

- Check lap belt, and securing components; at regular intervals for any sign of fraying or damage.
- Replace if necessary.
- Clean the lap belt with warm soapy water and allow to dry.
- The lap belt should be adjusted to suit the end user as detailed above.
- Sunrise Medical also recommend that the length and fit of the belt is checked on a daily basis to reduce the risk of the end user inadvertently re-adjusting the belt to an excessive length.
- If in doubt about the use and operation of the seat belt then ask your healthcare professional, wheelchair dealer, carer or attendant for assistance.

⚠ WARNINGS!

- The rider plus item should never exceed a total weight as defined in Section 16 Specification Sheets.
- Before you use the chair, carefully check the functionality.
- If you discover any chair malfunction, take it to be repaired or reset. Your dealer can help you to find the fault and correct it.
- Make sure batteries are charged. Do not use the chair when battery is low. The chair may come to a sudden, unexpected stop.
- Be aware that there is a point during every transfer when the wheelchair seat is not below you.
- Use extra care when you drive your chair in reverse. If one of the wheels hits an obstacle, you could lose control of the chair or fall out.
- Never use your chair on a slope unless you are sure you can do so without losing traction.
- Lift the chair only by non-detachable parts of the main frame.
- Never short-circuit electrical connections as you could cause an explosion.
- Do not use this chair if fitted with pneumatic tyres that are under or over-inflated.
- When using mobile phones you should switch off the chair to avoid causing electromagnetic radiation.

6.14 Rear View Mirror:

To fit the rear view mirror, (Fig.6.8 - 6.10):

- The swing away joystick mount contains an integrated mirror mounting feature. To fit the mirror the swing away joystick mount will need to be reconfigured. Refer to Service Manual for details.
- Following reconfiguration of the swing away joystick mount, Insert the stem of the mirror into the hole in the parallel swing-away, (A).
- Fit the washer and nut onto the thread of the mirror stem, (B).
- Tighten the nut just enough to allow the mirror to be positioned correctly for the user, (Fig 6.9).
- Use a 13.0mm spanner to fully tighten the nut to a torque of 10.0Nm, (Fig.6.10).

⚠ WARNING!

- Take care when close manoeuvring as the mirror may catch on people or objects.
- Do not hang objects off the mirror.
- If affected by glare, tilt the mirror slightly.
- Keep the mirror clean.

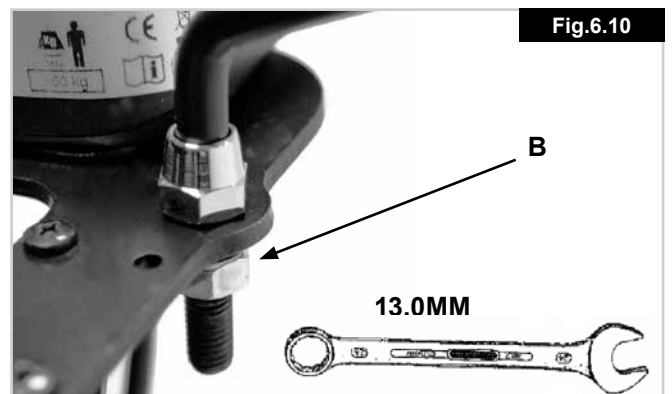
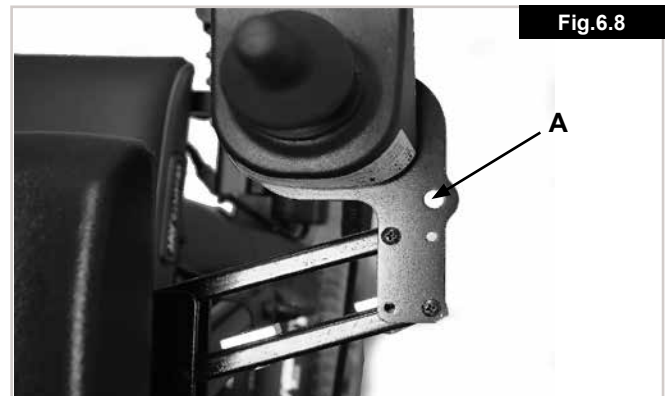

7.0 Assembly:

7.1. Footrest (Fig. 7.0-7.1):

The Q100R.Q200R is supplied with two models of Swing away footrest.

The footrests can be swung away by pulling the release lever back towards the seat and pushing the hanger outwards. To remove the footrest, activate the release lever, rotate the footrest approximately 90° outwards and then pull it out upwards. To refit the footrest follow the reverse procedure and the lock engages automatically when swung inward.

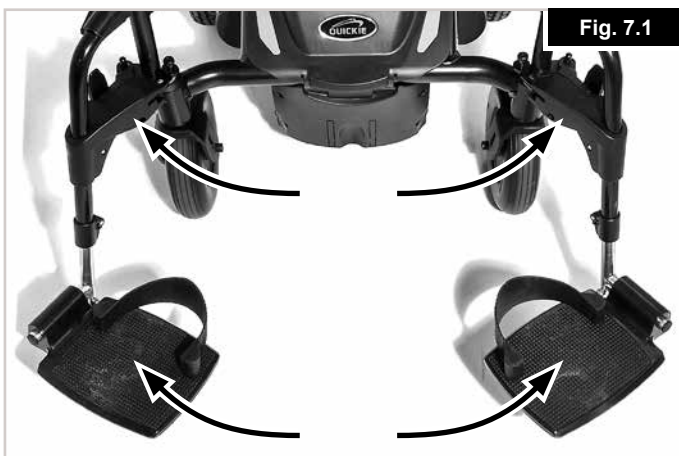

7.2. Armrest (Fig. 7.2):

Slide the armrest tube into the receiver of the wheelchair and turn the lever to the right to secure it. If you require a different individually fixed armrest height, you can set this using the adjusting screw on the connecting tube.

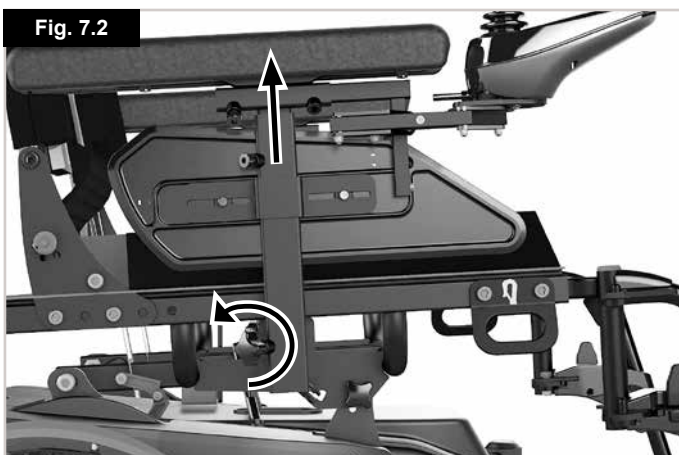

7.3. Anti-tip wheels (Fig.7.3):

These are mounted when the wheelchair leaves the factory. The anti-tip wheel tube is welded to the main chassis of the wheelchair frame.

Note: Anti-tips wheels may interfere with kerbs when mounting or dismounting. Follow the instructions in sections 6.9 & 6.10.

WARNING!

Never use the wheelchair without the anti-tip wheels fitted.



7.4. Kerb climber (Fig. 7.4):

- The Q100R and Q200R are available with a kerb climber option, this can be fitted by your powerwheel chair supplier.
- Fitting the kerb climber
- Remove the plastic cover at the front of the wheelchair by removing the 4 mounting screws.
- Remove the two thin push out pieces from the plastic cover.
- Mount the two side plates of the kerb climber through the provided holes of the front tube and tighten to 20-25Nm.
- Reassemble the plastic front cover – carefully guiding this over the two side plates of the kerb climber. Replace the 4 screws and tighten to 1-2Nm.
- Mount the kerb climbing wheel through the provided hole and tighten assembly to 10-15Nm.
- Check assembly is fully tightened before use.



7.5. Batteries (Fig.7.5):

For removal of batteries see section 11.0 for details
To disconnect the batteries.

- Remove the front Battery cover by lifting upwards at the handle provided at the front of the cover.
- Undo the two GREY plugs that connects the two batteries together.

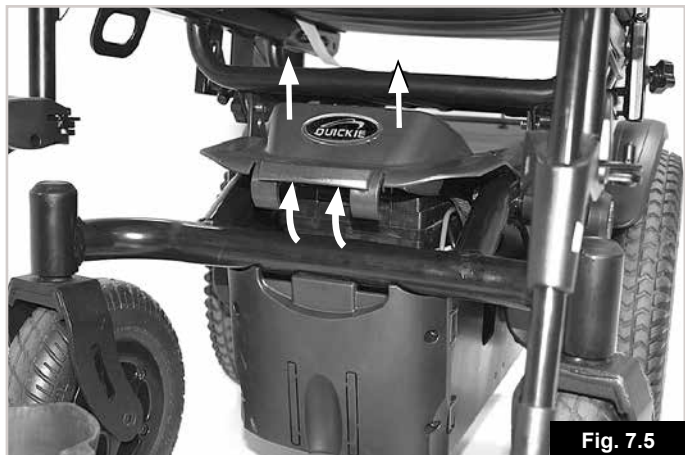

Fig. 7.5

7.6. Wheels (Fig.7.6 & 7.7):

If it is necessary to remove the wheels, to repair a damaged tyre for example, proceed as follows:

WARNING!

All wheels are safety critical items. If you are unsure about performing these tasks, please contact your approved Sunrise Medical dealer.

Front castor wheel:

Q100 (Fig. 7.6.1)

- Use a 6 mm. Allen wrench & 13.0mm spanner to remove the wheel axle from the fork.
- Remove the damaged wheel.
- When the wheel has been repaired, follow the reverse procedure to refit.
- Tighten the axle to a torque of 13-17 Nm.

Q200 (Fig. 7.6.2)

- Use a 5 mm. Allen wrench & 13.0mm spanner to remove the wheel axle from the fork.
- Remove the damaged wheel.
- When the wheel has been repaired, follow the reverse procedure to refit.
- Tighten the axle to a torque of 13-17 Nm.



Rear drive wheel (Fig.7.7):

- Loosen the 3 studs with a 17mm socket.
- Elevate the wheel using blocks.
- Remove the studs & damaged wheel.
- When it has been repaired, follow the reverse procedure to refit.
- Tighten the 3 studs to a torque of 40-45Nm

Note: The rear wheels are designed as separate rims and can be disassembled to simplify changing the tube or tyre.



⚠ WARNING!

The Lap Belt is a safety critical item. If you are unsure about fitting it, please contact your approved Sunrise Medical dealer.

7.7. Fitting The Lap Belt :



- 1) Remove Lap belt from bag, (Fig.7.8).
- 2) Fix the lap belt to the backrest bracket using the hole provided, (Fig.7.9).
- 3) The Lap Belt should look like this when fitted, (Fig.7.10),

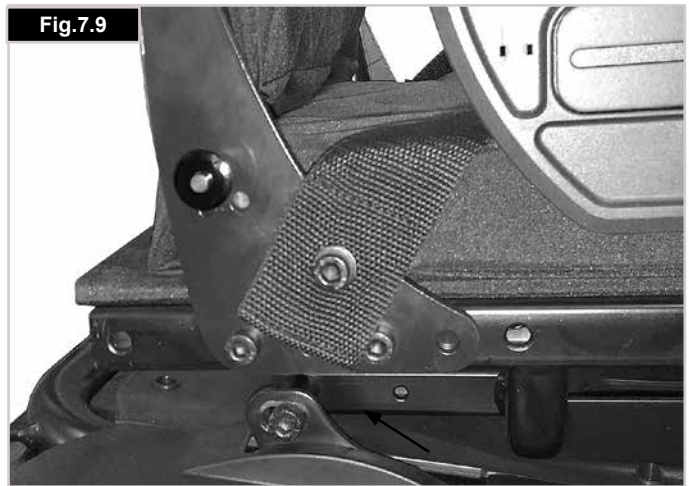

7.8 Crutch Holder, (Fig.7.11):

⚠ WARNING!

- Ensure that the crutch is securely fastened to the crutch holder.
- Ensure that the crutch is not interfering with the mechanisms of the chair.
- Ensure that the crutch does not protrude from the chair.
- Do not attempt to remove the crutch whilst the chair is in motion.
- Always come to a complete stop and turn off the power to the controls before attempting to remove the crutch. This will avoid accidentally operating the chair.

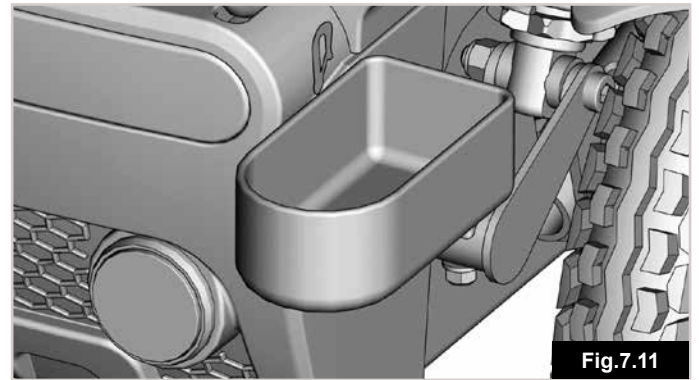

7.9 Lights and indicators, (Fig.7.12-7.13):

Where fitted, ensure that the lights and indicators are functioning correctly and lens are clean before going outdoors at night.

Lights assemblies can become very hot - Care must be taken if removing them for repair.

NOTE: Please contact your local Sunrise medical approved servicing agent for any warranty, service or repair work required.



8.0 Using The Wheelchair:

WARNING!

Parts of the wheelchair are heavy. Please use correct lifting techniques.

If you are unsure about lifting or removing any assemblies, or performing any other task requiring physical effort, get someone to help you who can manage the task.

8.1 Preparing for stowed transportation:

Remove the batteries as described in section 7.5 and Chapter 11.0

To lift the batteries please use the handles on the webbing straps surrounding the batteries.

Ensure that the cushion, back, are removed or folded & foot plates are flipped up or removed.

To lift the chair please use the tie down hooks.

8.2 To use the wheelchair again:

Reverse the above procedure ie;

Put the cushion, kerb climber, backrest & foot rests back in place. Refit the batteries.

WARNING!

Never lift the wheelchair by the armrests or foot rests, since they are detachable parts and harm could be done to the user or to the wheelchair.

8.3 Mechanical Fixed Reclining back (90° to 102° - 4 positions) (Fig. 8.1)

The backrest can be adjusted in 4° increments by removing the two quick release pins (fig 8.1).



The backrest spacers can be fitted in 2 positions (fig 8.1.1 and fig 8.1.2)



When assembled as shown in figure 8.1.1 it is possible to select 94 or 102° recline

When assembled as shown in figure 8.1.2 it is possible to select 90 or 98° recline

Pull the backrest spacers from the backrest tube and push back on in desired position

Choose the required backrest angle from the 2 available settings, re-insert quick release pins to fix recline angle..

WARNING

Ensure the Quick release pins are fully engaged into the selected hole.

8.4 Fixed Seat Tilt:

The seat can be tilted and set manually within a range of 0°, 3° 6° (Fig.8.2).

- Loosen the two rear M10 bolts (1)
- Undo the 2 front wing screws (2)
- Move the seat to the desired tilt angle.
- Replace and tighten the 2 wing screws (2)
- Retighten the two M10 bolts (1) to 10/12Nm.

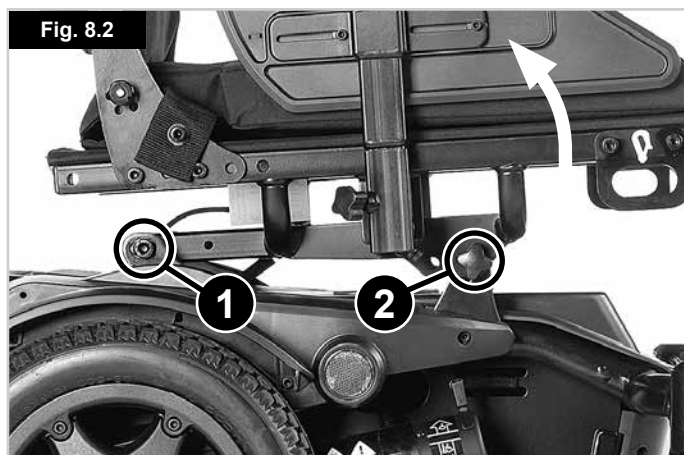

8.5 Freewheel device (Fig. 8.3):

Pull brake release lever away from battery box so that it is the freewheel position. If you wish to push the wheelchair with the motors off, you should follow this procedure with both wheels. When the levers are pushed inwards, the drive wheel will automatically connect with the propulsion mechanism. Follow this procedure with both wheels.

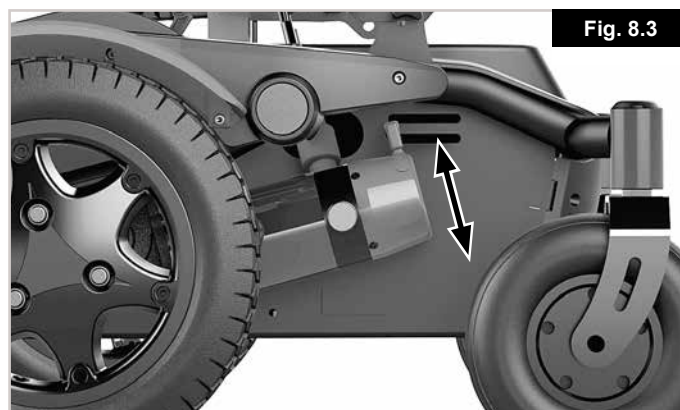

8.6. Tyre pressure:

Where pneumatic tyres are fitted, It is important to check inflation pressure regularly, along with the state of wear of the tyres. The maximum pressure recommended for the front wheels is 36 psi (2.5 bars), while for the rear wheels it is 40 psi (2.7 bars).

WARNING!

Never inflate the tyres with a service station air pump. It is recommended that you use a manual pump or a pressure regulator (manometer).

8.7 Transfers (Fig.8.4):

Always position the wheelchair close to the place where the transfer will be carried out. It is important

that the controller is turned OFF, so that the wheelchair will not move throughout the procedure. The wheelchair is highly stable

owing to its weight. Do not stand up on the footrests at any time during the transfer.



8.8 Slopes (Fig.8.5):

The following instructions explain how to manoeuvre correctly on steep ramps and slopes, especially in the course of descent.



⚠ WARNING!

- If your chair has a powered seat tilt, powered recline or manual recline back, we strongly recommend that you bring the backrest into an upright position and set the seat tilt to the level position.
- If you stop on an incline, start off slowly and, if necessary, lean forward to counteract the tendency of the front wheels to rise.
- On descents it is important not to allow the wheelchair to exceed normal speed. Indeed, the safest course is to go down steep hills slowly and to stop immediately if you have any doubts about the steering.
- If the chair gathers speed, move the joystick to its central position to slow down, or stop completely.
- Start off again slowly and do not allow speed to increase. Make sure the automatic brakes are engaged.
- Climbing or descending a slope with the automatic brakes disengaged can be dangerous.

As guidance for safe use on a slope we reviewed the effect of chair stability at two user weights 75kg and maximum user weight for both the Q100R (125kg) and Q200R models (136kg).

The graphic below (Fig. 8.6) shows the range in rearward dynamic stability for Q100R and Q200R when configured in least and most stable conditions* and when tested with 75kg and maximum user weights.

Maximum user weight range is shown by solid lines.

75kg user weight range is shown by dashed lines.

* Least stable configuration defined as:

Max seat depth (510mm), maximum seat tilt (6°) and maximum recline (12°).

Most stable configuration defined as:

Minimum seat depth (410mm), minimum seat tilt (0°) and minimum recline (0°).

⚠ CAUTION!

- These figures are meant as a guide to understand the effect of user weight and chair configuration on dynamic stability
- Real world stability can be affected by body composition, slope surface conditions, accessories, alterations to chair programming and so forth
- Chair may lose traction/slide before tipping on steeper slopes

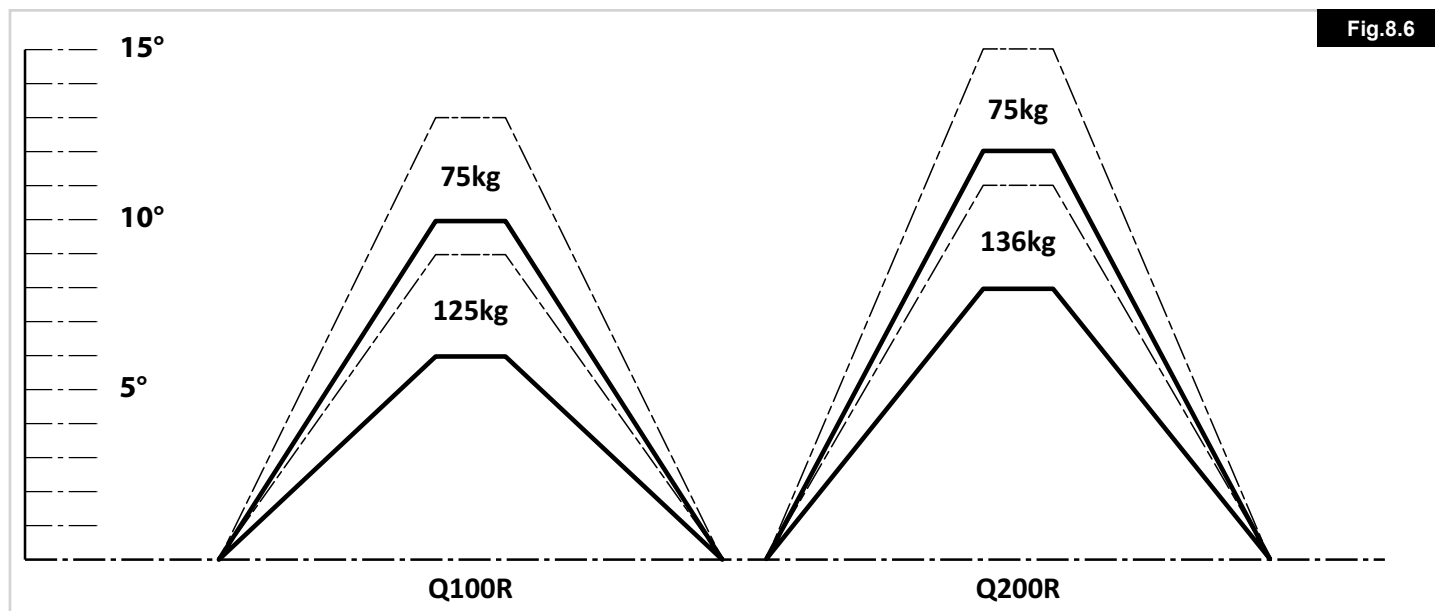

8.9 Laterals (Fig.8.7-8.8)

To Adjust the Width.

Slacken screw with 4mm Allen wrench, rotate lateral and retighten screw 4-7Nm.

To Adjust the Height.

Slacken both clamps with 4mm Allen wrench. Re-position lateral, retighten clamps 5-7Nm.

⚠ WARNING!

- Laterals should only be adjusted by medically trained personnel.
- Do not hang objects from the pads or brackets.

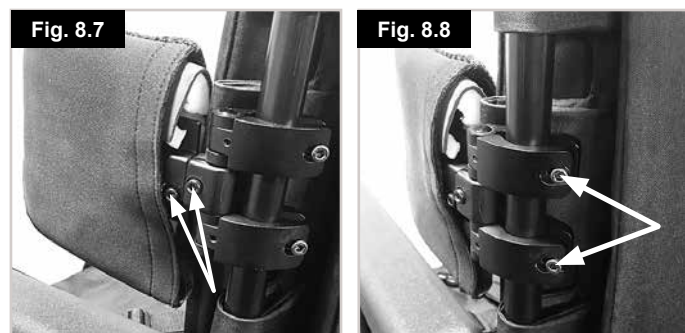

8.10 Mounting a kerb or step (Fig. 8.9):

Always approach a kerb at 90 degrees, For larger kerbs (step) head on driving forwards slowly and steadily and always at a 90 degrees angle. As the kerb climber or castor makes contact with the kerb (step), the wheelchair should be moving slowly. Small kerbs can be climbed from a standstill. Apply sufficient power to the motors to lift the front of the chair up onto the kerb (step) and then apply slightly more power and speed so that the drive wheels climb the kerb (step) smoothly and without hesitation. As far as possible, keep the joystick in the straight forward position. In accordance to the ground clearance, the maximum obstacle height possible to climb is 70mm without Kerb climber and 100mm with the optional kerb climber.

⚠ WARNING!

The approach speed and process can vary depending on your wheelchair performance and castor wheel choice between the Q100R and Q200R models.

8.11 Dismounting the kerb (Fig. 8.10):

- Reverse the chair slowly and carefully until both rear wheels are on the edge of the kerb, again in a 90 degrees position to the kerb.
- Reverse as slowly as possible off the kerb with the rear wheels. You will feel more secure if you can lean forward, but if you can't, don't worry, the wheelchair is extremely stable. As long as you stay within its limitation, you will be quite safe.
- The front of the chair will naturally follow down the kerb as you continue to drive slowly backwards.

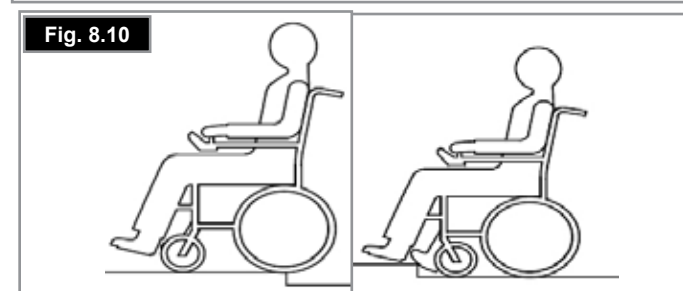
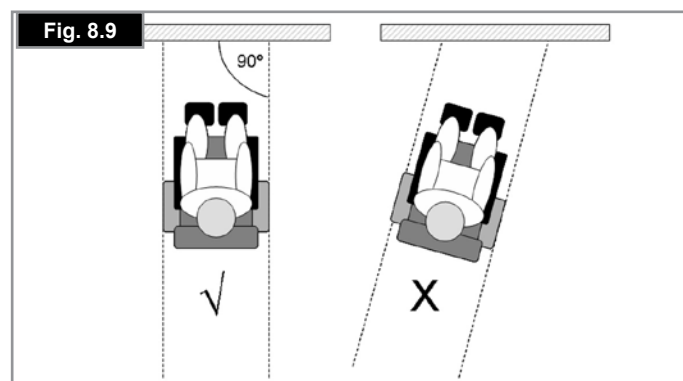

9.0 VR2 Control System (Fig.7.1):

Your wheelchair is controlled by the Joystick. This regulates the power & speed of the wheelchair. The Joystick determines the speed and direction of the wheelchair.

9.1 On/Off button:

The On/Off button applies power to the control system electronics, which in turn supply power to the wheelchair's motors.

WARNING!

Do not use the on/off button to stop the wheelchair unless there is an emergency. (If you do you may shorten the life of the wheelchair drive components).

9.2 Battery Level Indicator:

The battery gauge shows you that the wheelchair is switched on. It also indicates the status of the wheelchair. Refer to Fig.9.1.

9.3 Locking/unlocking the wheelchair:

The VR2 control system can be locked to prevent unauthorised use. The locking method is via a sequence of key presses and joystick movements as detailed below.

To lock the wheelchair;

- While the control system is switched on, depress and hold the On/Off button.
- After 1 second the control system will beep. Now release the On/Off button.
- Deflect the joystick forwards until the control system beeps.
- Deflect the joystick in reverse until the control system beeps.
- Release the joystick, there will be a long beep.
- The wheelchair is now locked.

To unlock the wheelchair;

- Use the On/Off button to switch the control system on. The maximum speed/profile indicator will be rippling up and down.
- Deflect the joystick forwards until the control system beeps.
- Deflect the joystick in reverse until the control system beeps.
- Release the joystick, there will be a long beep.
- The wheelchair is now unlocked.

WARNING!

To avoid unexpected or unintentional movement of the wheelchair and to conserve battery power, it is recommended that the control system is switched Off when drive or seating adjustments are not being used.



Fig. 9.1

9.4 Operating the control joystick:

When engaging the main On/Off button, allow a few seconds prior to moving the joystick. This allows the system to self check. If you move the joystick too soon, the battery level indicator display will not illuminate until the joystick is released.

If the joystick is off centre at the time of switching on, after 5 seconds a system error will occur.

Whilst this is not harmful to your wheelchair, you will need to switch off and then back on to clear the system.

Note: This is a safety feature to prevent unintended movement.

Proportional control summary:

Steering.

To steer the chair simply move the joystick knob in the desired direction. The further you move the joystick from the central position, the faster the wheelchair will travel in the direction the joystick is pushed.

Look ahead while you drive, not at the controls.

Stopping.

When the joystick returns to its central position, the brakes will activate automatically.

Braking Distance.

On flat ground, braking distance is approximately equal to the length of the wheelchair. Going downhill the braking distance may be slightly longer.

Forward/Reverse.

WARNING!

It is important that you stop the wheelchair before you change direction from forward to reverse.

WARNING!

Always turn the controller off before you transfer in or out of the wheelchair.

9.5 Maximum speed/profile indicator:

This is a gauge which shows the maximum speed setting for the wheelchair or if the control system is programmed for drive profile operation, the selected drive profile. This gauge also indicates if the speed of the wheelchair is being limited or if the control system is locked.

9.6 The horn button:

The horn will sound while this button is depressed.

9.7 Speed/Profile decrease button:

This button decreases the maximum speed setting or, if the control system is programmed for drive profile operation, selects a lower drive profile.

9.8 Speed/Profile increase button:

This button increases the maximum speed setting or, if the control system is programmed for drive profile operation, selects a higher drive profile.

Remember that only with practice will you become a competent driver. Find a safe, hazard free environment to practice controlling the wheelchair and familiarise yourself with the controls and functions.

9.9 VR2-L

There are common controls between the VR2 and the VR2-L control systems where a control differs it will be described below. All common controls can be found on the previous page.

Lights and indicators:

The wheelchair can be equipped with lights and indicators. Where lights are not factory fitted, they may be fitted as an optional extra by an approved Sunrise Medical authorised dealer.

WARNING!

Ensure that the lights and indicators are functioning correctly and lenses are clean before going outdoors at night.

Indicators:

To turn on the wheelchairs indicators operate the required button either left or right, the associated LED will also illuminate continuously.

If the LED flashes rapidly either a total short circuit, a single lamp open circuit or a total open circuit in the left or right indicator circuit has been detected.

Depress the indicator button to turn off the indicator and the associated LED.

Main lights:

To turn on the wheelchairs lights operate this button, the associated LED will illuminate continuously.

If the LED flashes a short circuit in the lighting circuit has been detected.

Depress the light button to turn off the lights and the associated LED.

Hazard warning lights:

To turn on the wheelchairs hazard warning lights operate this button, the associated LED will flash at the same rate. The left and right turn indicator LEDs will also flash.

If the LED flashes rapidly either a total short circuit, a single lamp open circuit or a total open circuit in the entire indicator circuit has been detected.

Depress the hazard warning button to turn off the lights and the associated LED.

Actuator button and LEDs:

Depending on whether your wheelchair is fitted with one or two actuators the operation of this button will differ.

Wheelchairs with one actuator

Depressing the actuator button will enter actuator adjustment mode. This will be indicated by the illumination of both actuator LED's. Actuator adjustment can then be made by deflecting the joystick forwards or backwards. To re-enter drive mode, depress either actuator button.

Wheelchairs with two actuators

Depressing the actuator button will enter actuator adjustment mode. Depressing the button once illuminates the left LED, and deflection of the joystick will adjust the actuator motor connected to that channel. If the right button is depressed the associated LED will be illuminated, and deflection of the joystick will adjust the actuator motor connected to the other channel.

To re-enter drive mode, depress the selected actuator button, as indicated by the associated LED.

It is also possible to select the other actuator by left or right movements of the joystick.



Fig. 9.2

9.10 Charging and programming socket:

(Fig.9.10)

⚠ WARNING!

- This socket should only be used for programming and charging the wheelchair.
- This socket should not be used as a power supply for any other device.
- Connection of other electrical devices may damage the control system or affect the EMC performance of the wheelchair.

See Section 11.0 about charging.

The programming socket will enable an approved Sunrise Medical authorised dealer to re-programme your chair and also gain useful information when tracing any faults. When the chair leaves the factory, the parameters of the controller are set to default.

To programme the controller you need a special programming device (handheld or PC software), which is available to your Sunrise Medical authorised dealer.

⚠ WARNING!

Programming the controller of the wheelchair is only allowed through authorised personnel trained by Sunrise Medical. Incorrect controller settings could cause driving outside the safe limits and could result in damage or injury.

Note: Sunrise Medical does not accept responsibility for damages which result from unexpected movement or stopping of the wheelchair due to inappropriate programming or unauthorised use of the wheelchair.

9.11 VR2 dual control unit:

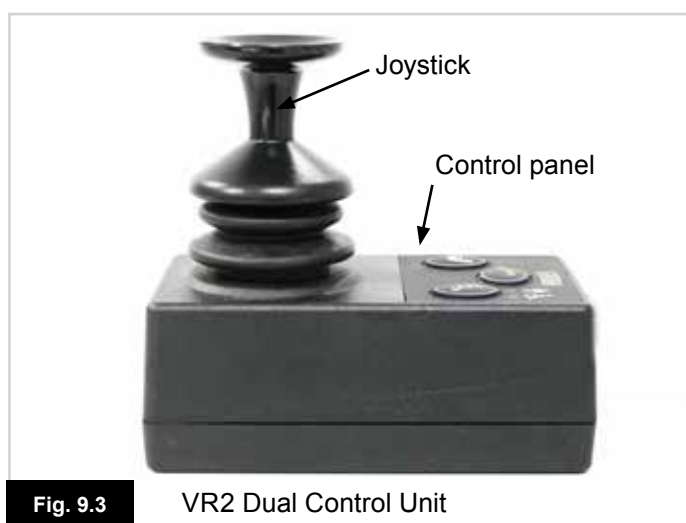

Fig. 9.3

VR2 Dual Control Unit

9.12 Control button and indicator:

This shows which joystick has control. If the red wheelchair light is on the wheelchair occupants joystick has control. If the green attendant light is on the dual attendant systems joystick has control. The button is used to transfer control between the two choices, (Fig.9.4).

9.13 Actuator button and LED:

All VR2 dual attendant systems have an actuator button fitted as standard. If the VR2 is programmed with no actuators then this button has no function, (Fig.9.4).

Wheelchairs with one actuator:

Depressing the actuator button once will enter actuator adjustment mode. This will be indicated by the illumination of both actuator LED's. Actuator adjustment can then be made by deflecting the joystick forwards and backwards. To re-enter drive mode, depress either the actuator button or the speed button.

Wheelchairs with two actuators:

Depressing the actuator button will enter actuator adjustment mode. Depressing the button once illuminates the left LED and deflection of the joystick forwards or backwards will adjust the actuator connected to that channel. Selection between the two actuators is achieved by deflecting the joystick to the left and right. As the actuator selected changes so will the LED which illuminates. Left for actuator 1 and right for actuator 2.

To re enter drive mode, depress either the actuator button or the speed button.



Fig. 9.4

9.14 Maximum speed button and indicator:

This shows the maximum speed setting for the wheelchair when the dual attendant system has control. There are five settings - setting 1 is the slowest speed and setting 5 is the highest speed. The speed setting is changed with the speed button, (Fig.9.4).

If the control system is programmed for drive profile operation, then the dual attendant system speed adjuster will only adjust the speed within the selected profile. Changing between drive profiles can only be achieved using the VR2 main joystick.

WARNING!

To avoid unexpected or unintentional movement of the wheelchair and to conserve battery power, it is recommended that the control system is switched Off when drive or seating adjustments are not being used.

Note: Always move the chair with care.

If the programming of the attendant drive profile (s) needs adjustments to make it more convenient for the attendant and/or the person sitting in the wheelchair, please contact your Sunrise Service agent for adaptation.

If the direction of movement of the directional attendant control needs to be altered, please contact your authorised Sunrise Medical dealer for adaptation.

WARNING!

Do not attempt to program the wheelchair yourself. Always consult a qualified health care professional. Contact your Sunrise medical approved dealer for details.

10.0 Troubleshooting The VR2 Hand Control:

Always consult your Sunrise Medical authorised dealer when a diagnostic fault has appeared on your hand control.

The battery gauge and maximum speed/profile indicator show the status of the control system, (Section 7.0, Fig.7.1).

Battery Gauge is steady - This indicates that everything is OK.

Battery Gauge flashes slowly - The control system is functioning correctly but the batteries need charging as soon as possible.

Battery Gauge steps up - The wheelchair batteries are being charged. You will not be able to drive the wheelchair until the charger is disconnected and you have switched the control system off and on again.

Battery Gauge flashes rapidly (even with the joystick released)

The control system safety circuits have operated and the control system has been prevented from moving the wheelchair.

This indicates a system trip. i.e. the VR2 has detected a problem somewhere in the wheelchairs electrical system.

- Switch off the control system.
- Make sure that all connectors on the wheelchair and the control system are mated securely.
- Check the condition of the battery.
- If you can't find the problem, try the self help guide on the next page.
- Switch on the control system again and try to drive the wheelchair.
- If the safety circuits operate again, switch off and do not try to use the wheelchair.
- Contact your Sunrise Medical authorised dealer.

Self help guide, (Fig.10.1). (See next page).

If a system trip occurs you can find out what has happened by counting the number of bars on the battery gauge that are flashing.

Go to the number on the list which matches the number of flashing bars and follow the instructions.

Slow or sluggish movement - If the wheelchair does not travel at full speed or does not respond quickly enough and the battery condition is good, check the maximum speed setting. If adjusting the speed setting does not remedy the problem then there may be a non hazardous fault. Consult your Sunrise Medical authorised dealer.

Speed/Profile Indicator ripples up and down - This indicates the control system is locked, refer to section 7.3 for details on how to unlock the control system.

Speed/Profile Indicator flashes - This indicates that the speed of the wheelchair is being limited for safety reasons. The exact cause will depend on the build of the chair but usually indicates that the seat is elevated.

Actuator LED flashes - This indicates that the actuators may be inhibited in one or both directions.

Fault code										Possible cause	
											The batteries need charging, or there is a bad connection to the battery. Check the connections to the battery. If the connections are good, try charging the batteries.
											The left hand motor has a bad connection. Check the connections to the left hand motor.
											The left hand motor has a short circuit to a battery connection. Contact your Sunrise Medical authorised dealer.
											The right hand motor has a bad connection. Check the connections to the right hand motor.
											The right hand motor has a short circuit to a battery connection. Contact your Sunrise Medical authorised dealer.
											The wheelchair is being prevented from driving by an external signal. One possibility is that the battery charger is plugged in.
											A joystick fault is indicated. Make sure that the joystick is in the centre position before switching on the control system.
											A control system fault is indicated. Make sure the control system connections are secure.
											The parking brakes have a bad connection. Check the parking brake and the motor connections. Make sure that the control system connections are secure.
											An excessive voltage has been applied to the control system. This is usually caused by a poor battery connection. Check the battery connections.
											+ S S = Speed indicator LED's A communication fault is indicated. Make sure that the joystick cable is securely connected and not damaged.
											+ A A = Actuator LED's An actuator trip is indicated. If more than one actuator is fitted, check which actuator is not working. Check the actuator wiring.

Fig. 10.1

11.0 Batteries and Charging:

WARNING!

Please read the owner's manual supplied with the charger carefully. The general procedures and effects for the interference with the chair and the batteries remain valid.

WARNING!

Do not expose any part of the battery to direct heat (i.e. naked flame, gas fire).

WARNING!

When charging always place your charger on a hard surface in a room with good ventilation.

WARNING!

You should not charge your batteries in outdoor conditions.

11.1. Battery & Charger Specification:

Batteries:

24 V (2x12V) / 55Ah (C20)

Dimensions: 229 x 138 x 211 mm

Charger:

Connector: 3 pin Neutrik XLR

Charger: 24 Vd.c. 8 A

11.2 Electrical fuses:

To prevent the wheelchair from becoming overloaded, fuses been built into the battery looms. The fuses automatically isolate the battery from the wheelchair wiring and control systems in the event of an electrical short circuit.

If you suspect that the fuses have blown, contact your Sunrise Medical authorised dealer as soon as possible, who will carry out a full diagnostic to determine the cause of the original the fault.

WARNING!

Do not attempt to change the fuses yourself.

Do not attempt to by-pass the fuse as this would be very dangerous.

Contact your Sunrise Medical authorised dealer as soon as possible.

11.3 Batteries (Fig. 11.1 - 11.6):

For removal of batteries:

- Remove the front Battery cover by lifting upwards at the handle provided at the front of the cover (Fig. 11.1).
- Undo the two GREY plugs that connects the two batteries together (Fig. 11.2).
- Remove legrests
- Remove two cap screws from rear of top shroud with 4mm Allen wrench (Fig. 11.3).
- Remove wing screws
- Lift the front of the seat upwards (Fig. 11.4)
- Carefully push the seat support brackets (1) backwards to lock the seat in the lifted position then remove two cap screws (2) from front of top shroud with 4mm Allen wrench (Fig. 11.5)
- Loosen the two M10 cap screws at rear of seat assembly
- Release Velcro straps holding the two batteries in place
- Remove the two batteries from the base – taking care not to move the raised seat frame (Fig. 11.6).
- Replace batteries, taking care to align terminal positions correctly (see fig 11.7)
- Secure batteries with Velcro straps
- Replace top shroud, tighten front cap screws to a torque of 1-2Nm
- Carefully pull red seat support forward while supporting seat to unlock/lower seat
- Select desired seat tilt angle, replace wing screws and tighten
- Tighten two M10 cap screws to a torque of 10-15Nm
- Tighten top shroud rear cap screws to a torque of 1-2Nm
- Reconnect batteries GREY connectors
- Replace legrest and front battery cover.

DANGER!

Do not short circuit the battery terminals. Remember that spanners or jewelry are conductive and if dropped across the battery terminals may cause severe burns and/or explosion!

WARNING!

- The red seat support brackets are only intended to support the seating during maintenance operations. Excessive upwards force – example lifting the wheelchair while the seating is raised will damage the mechanism.
- Batteries are heavy. Use correct lifting techniques when removing them from the wheelchair and from the battery boxes.
- Always use the handles or straps provided to lift the batteries.

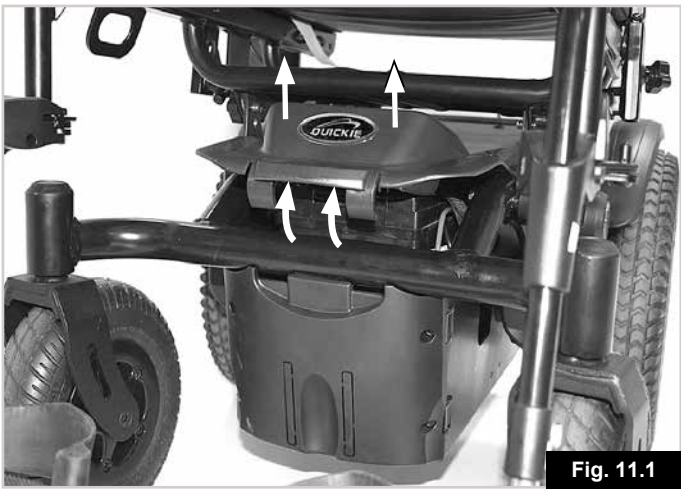

Fig. 11.1



Fig. 11.2



Fig. 11.3



Fig. 11.4

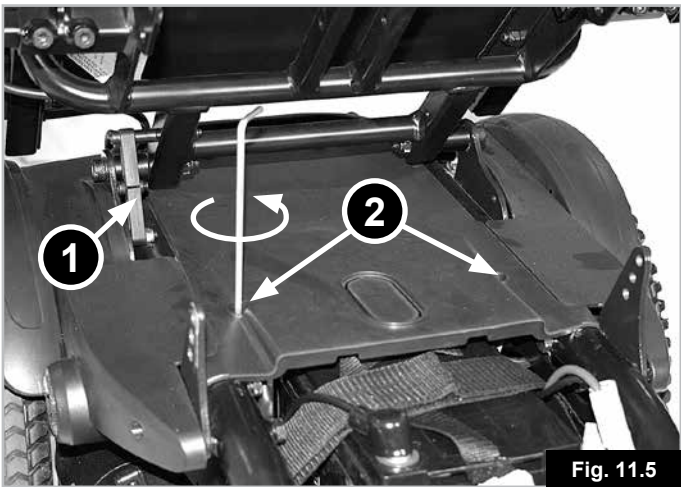

Fig. 11.5

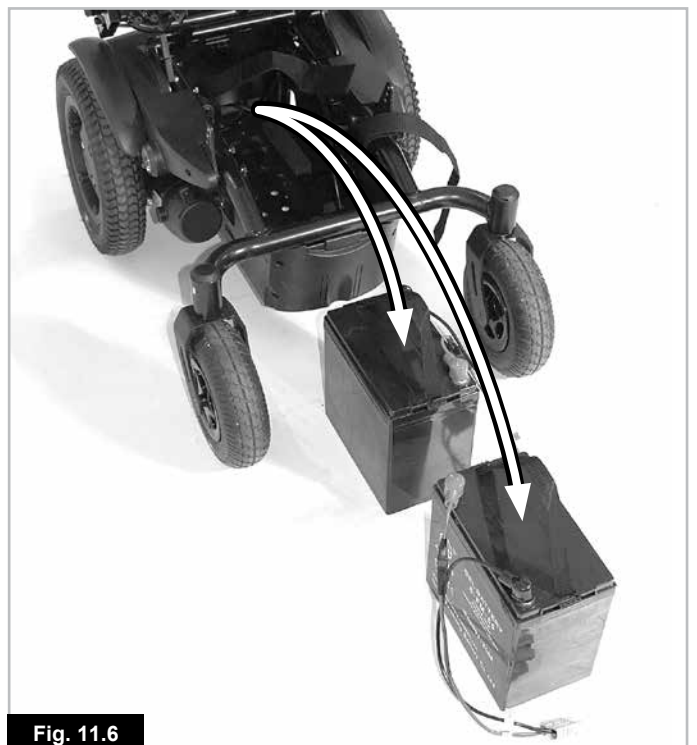

Fig. 11.6

11.4 General battery information:

Batteries are the power source for almost all of the modern mobility products available today. The design of batteries used in mobility products is significantly different to the batteries used to start a car for example. Car batteries are designed to release a large amount of power over a short period of time, whilst mobility batteries (commonly called deep cycle batteries) release their power evenly, over a long period of time. Therefore, due to the lower production volumes and increased technological requirements, mobility batteries are typically more expensive.

Commonly two 12 volt batteries are used together in a mobility product, giving a total voltage of 24 volts. The size of the battery (e.g. its available power) is expressed in amps per hour e.g. 55 A/hr. The higher the number, the bigger the battery size, weight and, potentially, the greater the distance you can travel. Sunrise Medical only fit as standard maintenance-free batteries into these types of wheelchairs.

11.5 Maintenance-free batteries:

This type of battery uses a method of carrying the electrolyte commonly referred to as 'gel-type', that is held within the battery case. As the name implies, no maintenance is required other than regular charging. You can safely transport this type of battery without fear of acid spilling.

Furthermore, they are approved for transportation on aircraft, trains and ships.

11.6 Battery care:

Below is set out a battery care plan for maintenance-free batteries. This has been agreed between Sunrise Medical and the battery manufacturers, to enable you to get the best out of your batteries. If a different care plan is followed, this may result in lower than expected performance from your mobility vehicle.

11.7 Maintenance-free battery care plan:

- Only use an approved Sunrise Medical charger compatible with the vehicle to be charged.
- Charge your batteries every night, regardless of the amount of use your mobility device has had during the day.
- Do not interrupt the charging cycle.
- If your mobility device is not required for use, it should remain connected to the charger until required. This will not damage your batteries, as long as the mains socket/plug is left switched on. Turning the mains socket/plug off, but leaving the mains cable plugged in will eventually deplete your battery charge.
- If you leave your vehicle for an extended period (more than 15 days) charge the batteries fully and then disconnect the main battery lead.
- Failure to allow for recharge will damage the batteries and can lead to shortened distances and premature failure.
- Do not top up the charge of your batteries during the day. Wait until the evening for a full overnight charge.
- As a general rule, maintenance-free batteries take longer to fully charge than lead acid batteries.
- The battery terminals need to be checked regularly for signs of corrosion. If any corrosion is apparent, then clean the terminals completely (a wire brush is ideal) and re-grease the terminal using Vaseline petroleum jelly, not ordinary grease. Ensure that the terminal nut and bolt, cable clip and exposed cable are completely covered with jelly.
- Following all the points above should result in a healthier battery, greater range for the vehicle user and a longer life for your batteries.
- Return the batteries back to Sunrise Medical or directly to the battery manufacturer for recycling, when they no longer hold charge.

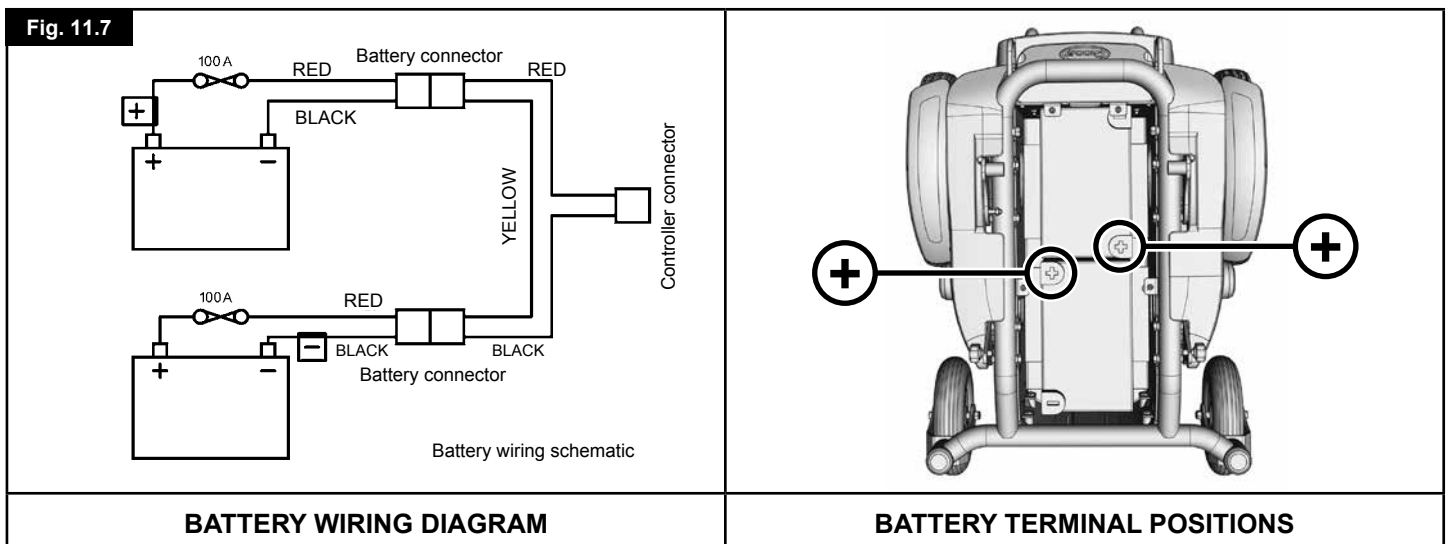

11.8 General charger information:

The external charger has been designed to charge two 12 V Gel type batteries connected in series (= 24 V).

11.9 Charger Specification:

WARNING!

Only use chargers for cyclic batteries, Gel-Type with 24V/8A output nominal max.



For more information about the charger operation, consult the instructions provided with the charger.

Note: If the charger is not connected to the control it does not output charge voltage.

WARNING!

It is possible that the charger's metallic box may slightly raise in temperature due to use.

11.10 Charger safety features:

The chargers have features which prevent hazards or accidents occurring as a result of connecting batteries the wrong way round, overheating caused by fault conditions or attempting to charge wrong voltage batteries.

The majority of charger sizes are electrically double insulated and no earth connection is required. Some larger sizes may be electrically earthed and this will be clearly stated on the label.

The 3 pin UK mains input plug contains a replaceable fuse. The rating of this fuse is shown on the charger label.

WARNING!

Always replace with the same type and size of fuse as specified. Fitting of different fuses can result in damage to the charger or failure of the charger to operate properly.

If your charger has been specified for use in Continental Europe it will contain a European two pin plug which does not have a fuse. In this case the fuse is located in the fascia panel of the charger.

11.11 Procedure for connecting the charger and charging:

- The wheelchair can be charged via the charger socket at the front of the VR2 remote control, (Fig. 11.8).
- Ensure the VR2 is switched off.
- First, connect the charger to the VR2.
- Then, connect the charger to the mains supply by means of the mains plug and switch on.
- Do not leave the charger connected to the battery with the mains disconnected or switched off. This could result in damage to your battery being caused by deep discharge over a period of time.
- Always switch off at the mains before disconnecting the batteries.



Fig. 11.8

11.12 Charger safety and caution notes:

WARNING!

- The charger is designed for indoor use. Do not use outdoors or expose to rain, snow, spray or moisture.
- When buying replacement batteries or charger always consult your Sunrise Medical service agent.
- The charger may be used with other brands of Gel type batteries, subject to written confirmation from the Technical Department of Sunrise Medical.

11.13 The range of your vehicle:

The batteries give the chair a range of approximately 30km depending on powerchair model Q100R or Q200R. Most manufacturers of mobility products state the range of their vehicles either in the sales literature or within the Owner's Manual. The range stated sometimes differs from manufacturer to manufacturer even though the battery size is the same. Sunrise Medical measure the range of their vehicles in a consistent and uniform manner, but variances still occur due to motor efficiencies and overall product load weight.

The range figures are calculated to I.S.O. Standard 7176. Part 4: Wheelchair Energy Consumption Theoretical Range.

This test is carried out in controlled conditions with new, fully charged batteries, on a level test surface and a user weight of 100 kg. The range figures stated should be seen as a theoretical maximum and could be reduced if any single, or combination, of the following circumstances occur:

- User weight heavier than 100 kg.
- Batteries whose age and condition are less than perfect.
- The terrain is difficult e.g. very hilly, sloping, muddy ground, gravel, grass, snow and ice.
- The vehicle climbs kerbs regularly.
- The ambient temperature is very hot or very cold.
- Incorrect tyre pressures in one or more tyres.
- Lots of start/stop driving.
- Also thick pile carpets within the home can affect range.
- Use of additional power consumption options (e.g. light, actuators, etc.).

The battery sizes available on each Sunrise Medical product should give sufficient range to cope with the majority of customer's lifestyles.

11.14 Common battery statements:

Over the years, battery technology has moved forward but, unfortunately, some of the advice given on battery care has not. This has resulted in a number of confused and at times contradictory instructions on the 'best' way to care for your batteries.

This section will help to dispel some of these myths and legends.

To reduce the risk of damage to electric plug and cord, pull by the plug rather than the cord when disconnecting the charger. Make sure the cord is located so that it will not be stepped on, tripped over or otherwise subjected to damage or stress. An extension cord should not be used unless absolutely necessary. Use of an improper extension cord could result in a risk of fire and electric shock. If any extension cord must be used, make sure the pins on the plug of the extension cord are the same number, size and shape as those of the plug on the charger; and that the extension cord is properly wired and in good electrical condition.

12.0 Adjustments:

12.1 Adjustment of the footrest (Fig. 12.1.1 & 12.1.2):

To adjust the height of a footrest:

Depending on footrest type, loosen the screw using either a 4mm allen wrench or an 11mm socket and set the footrest at the height desired, then tighten the screw in the hole.

Note: Make sure that the screws are tightened securely.

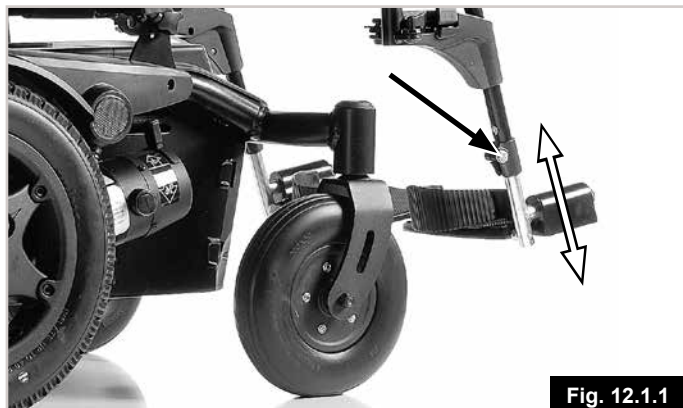

Fig. 12.1.1



Fig. 12.1.2

12.2 Inner Or Outer Width Adjustment of the footrests:

Using an optional kit the width between the footrests can be made 4cm larger or smaller than standard. An instruction sheet is included in the kit.



Fig. 12.2

12.3 Adjustment of the armrests:

Height adjustment (Fig. 12.3):

Loosen cap screw (arrowed), lift armpad to desired height, tighten cap screw to a torque of 3-7Nm.

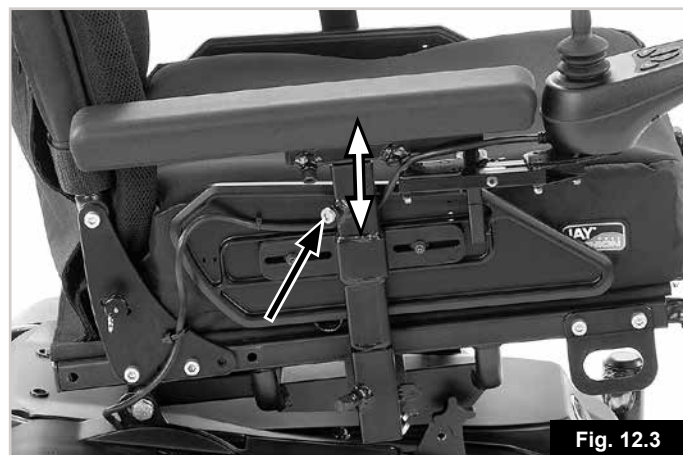

Fig. 12.3

12.4 Seat width adjustment (Fig. 12.4):

To adjust the width between the armrests, use a size 5mm allen wrench to loosen the cap screws on the armrest adapter retainers, which are located on the side frame below the armrests, and pull the armrests outwards or inwards to achieve the desired position. Tighten screws to a torque of 3-7Nm.



Fig. 12.4

12.5 Seat Centre of Gravity Adjustment:

The Q200R Configurable product has the added feature of Seat forward/rearward adjustment. This can be used to adjust the centre of gravity by moving the seat/user position relative to the base. Centre of gravity adjustment maybe necessary to both improve stability on slopes and tractions (driveability) for certain types of users.

⚠ WARNING!

Adjustments to the centre of gravity must ONLY be carried out by qualified Rehab engineers that have been trained and approved. Therefore instructions of how to make such adjustments are deliberately NOT included within this manual so they are only available to those qualified. Incorrect adjustment may lead serious lack of product stability and a risk of tipping or sliding which can result in serious injury.

12.6 Seat depth adjustments: (Fig. 12.6).

Remove the 2 bolts on the backrest brackets 1 for each side of the frame, using a 6mm Allen key and 13.0mm spanner. Move the backrest into the seat depth position required. Re-assemble bolts and tighten to a torque of 17-20Nm. To compensate for the armrest position, both the sideguard and the armpad are adjustable.

There are 5 Seat depths; 410 to 510mm in 25mm steps.

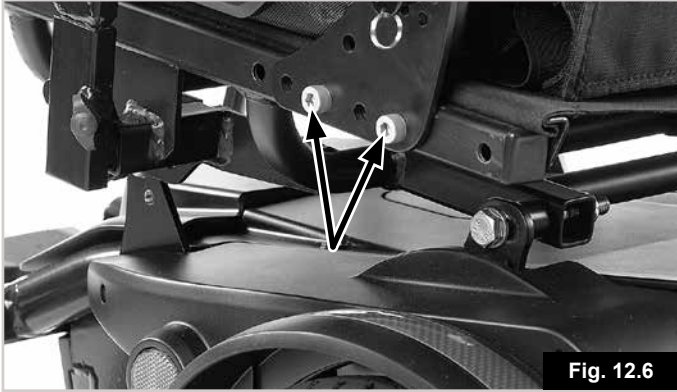

12.7 Control Adjustment (Fig. 12.7):

The control can be adjusted to various positions by pushing it along the armrest. The control can be moved by turning the lever below the arm pad anti-clockwise, reposition the controller and secure by turning the lever clockwise to tighten.

⚠ WARNING!

- Do not replace the joystick knob with any unauthorised item. It may cause hazardous operation and loss of control of the chair.
- It is important that the joystick boot is replaced if it is torn or brittle; failure to do so could cause substance damage to the controller and unexpected movement of the chair.
- Ensure that you always have comfortable access to the controls whilst the chair is moving and make sure that the controller is fixed securely to the chair.



12.8 Dual/Attendant control (Where fitted)

⚠ WARNING!

- Ensure that you set the speed of the attendant control to a speed that you can comfortably follow.
- Always turn off the power to the controller when leaving the user in the chair. (See sections 9.10 - 9.14).

12.9 Parallel swing-away control (Fig.12.8):

⚠ WARNING!

- Before adjusting the swing-away arm, switch off the controller to avoid accidental displacement of the joystick which would cause unwanted movement of your wheelchair.
- Keep your fingers and clothing, etc. clear while operating the swing-away mechanism.
- Be aware that the width of your chair has increased if the swing-away arm is out and you may not get between certain obstacles.
- Do not hang any items on or over the parallel swing-away remote assembly as this could damage the swing-away mechanism.
- When transferring to and from the wheelchair do not use the remote as a means of support.
- Keep fingers, clothing, etc. clear of the swing-away mechanism at all times.
- Ensure the power is switched off while adjusting the parallel swing-away arm.
- Only operate the wheelchair at low manoeuvring speed when the parallel swing-away is in use, (Fig.12.7).



12.10 Programming:

When the chair leaves the factory, the parameters of the controller are set to default. However, if any alterations are required, then you should contact your dealer, where a specialist can carry out this work.

Note: A programmer or a PC-based software program with the appropriate connecting lead are required to program the wheelchair.

⚠ WARNING!

Never attempt to programme the wheelchair yourself.

⚠ WARNING!

Programming the controller of the wheelchair is only allowed through authorised personnel trained by Sunrise Medical. Incorrect controller settings could cause driving outside the safe limits and could result in damage or injury.

13.0 Cleaning:

13.1 Cleaning General:

- The wheelchair should be wiped over once per week with a slightly damp, not wet, cloth and any fluff or dust that has accumulated around the motors should be blown or dusted away.
- Make sure that you dry all parts of your wheelchair if it becomes wet or damp after cleaning or if it is used in a wet or damp atmosphere.
- It is important that should the wheelchair be used by more than one person it is cleaned thoroughly to ensure there is no cross infection. You should use a proprietary disinfectant for this task. Please pay attention to the manufacturer's instructions of the disinfectant you are using.
- Inspect the upholstery/seating for tears, dents, wearing or slackening of upholstery particularly near to metal as this could result in poor posture or lower levels of comfort and pressure relief.

13.2 Cleaning seating:

All parts/accessories such as swing-away trays should be cleaned with a damp cloth.

All lateral supports, headrest, armrests, side-guards, calf pads, lap belts and kneepads should be cleaned with a damp cloth.

CAUTION!

Do not use a hose or a pressure washer to clean your chair.

13.3 Cleaning control system:

Clean the control system and the joystick with a cloth dampened with diluted detergent. Be careful when cleaning the joystick.

CAUTION!

Never use abrasive or spirit based cleaners.

13.4 Speciality controls:

Where fitted Ensure that joysticks (all variants) are cleaned with a mild disinfectant and a cleaning cloth to avoid any cross infection possibilities.

WARNING:

Ensure the controller is switched off before cleaning.

14.0 Shipping & Storage Requirements:

14.1 Storage temperature & humidity:

Storage Temperature: Min: -40°C Max: 65°C

Relative Humidity (non-condensing): Min:5% Max: 95%

14.2 Special shipping requirements:

The wheelchair may be transported by road, rail, sea or air and the batteries conform to IATA regulations.

CAUTION!

Before you travel, please contact the appropriate carrier. The travel operator will be able to supply details of any special requirements/instructions.

- Ensure that any detachable parts are secured with your mobility aid or separately packed and labelled so they do not get lost during loading and unloading.
- Take this Owner's Manual with you.
- The carrier will need to refer to the following sections.
- How to lock/unlock the Joystick, (Section 7.3).
- How to disconnect the batteries, (Section 9.3, Fig.9.1 to 9.9).
- How to disconnect the drive, (Section 6.10).

14.3 Medium to long term storage:

When storing your wheelchair for long periods of time (in excess of one week), follow these simple instructions:

Fully charge the wheelchair for at least 24 hours. Disconnect the batteries or battery boxes.

WARNING!

Never store your wheelchair;

- Outside.
- In direct sunlight, (plastic parts may discolour).
- Near a source of direct heat.
- In a damp environment.
- In a cold environment.
- With the batteries/battery boxes connected, (even if the controller is switched off).

Avoiding all of the above will minimise battery deep cycle discharge and extend battery lifetime.

When returning the wheelchair to use, please reconnect the batteries/battery boxes and charge the wheelchair for at least 24 hours before use.

15.0 Disposal:

The symbols below mean that in accordance with local laws and regulations your product should be disposed of separately from household waste. When this product reaches the end of its life, take it to the local collection point designated by local authorities. The separate collection and recycling of your product at the time of disposal will help conserve natural resources and ensure that it is recycled in a manner that protects the environment.

Ensure you are the legal owner of the product prior to arranging for the product disposal in accordance with the above.

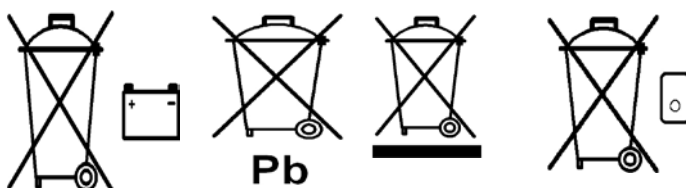

16.0 Specification sheets (EN 12184 & ISO 7176-15)

Sunrise Medical S.L.
 Polígono Bakiola, 41
 48498 Arrankudiaga – Vizcaya
 España
 Tel.: +34 (0) 902142434
 Fax: +34 (0) 946481575
 www.sunrisemedical.com

Operating temperature: - 25°C to 50°C
 Storage temperature: -40°C to 65°C
 Moisture resistance: IPx4
 No restrictions on humidity and air pressure

Model: Quickie Q100R



Maximum occupant mass:
 Q100R 125kg user.

The wheelchair Quickie
 Q100R conforms to the
 following standards:

a) requirements and test
 methods for static, impact
 and fatigue strengths
 (ISO 7176-8)

b) power and control
 systems for electric
 wheelchairs requirements
 and test methods (ISO
 7176-14)

c) climatic test in
 accordance with ISO
 7176-9

d) requirements for
 resistance to ignition in
 accordance with
 ISO 7176-16

e) the product is specified
 as a Class B power chair

f) all materials used on
 this product conform to
 EN1021 parts 1 and 2.

ISO 7176-15	Min	Max	Comments
Overall length (with legrest)	1010mm	1140mm	
Overall width powerbase	-	540mm	
Overall width seat	540mm	580mm	Armrests in / out
Folded length	770mm	780mm	
Folded height	640mm	680mm	
Total mass (w/batteries)	-	94kg	
Mass of the heaviest part	-	17kg	Battery
Mass of removable armrest	1.8kg	2.7kg	Without / with joystick
Static stability downhill	15°	-	
Static stability uphill	13°	-	
Static stability sideways	12°	-	
Energy consumption (Max. range)	-	31km	
Dynamic stability uphill	6°	10°	Least / most stable seat
Obstacle climbing	75mm	100mm	Without / with K.C
Maximum speed forward	-	6km/h	
Min. braking distance from max. speed	1000mm	-	
Seat plane angle	0°	6°	3 positions
Effective seat depth	410mm	510mm	5 positions
Effective seat width	430mm	500mm	
Seat surface height at front edge	450mm	490mm	Cushion removed
Backrest angle	0°	12°	4 positions
Backrest height	-	500mm	Cushion removed
Footrest to seat distance	350mm	480mm	Uni type hanger
Leg to seat surface angle	72°	75°	Depends on leg length
Armrest to seat distance	220mm	300mm	Cushion removed
Front location of armrest structure	385mm	460mm	
Minimum turning radius	800mm	-	
EN 12184	Min	Max	Comments
Maximum height of kerb safely descend	-	100mm	
Minimum width of corridor	1100mm	-	
Minimum ground clearance	90mm	-	45mm at anti-tips
Speed control operation force	-	1,8 N	
Direction control operation force	-	1,5 N	

NOTE: Some of the options and measures may be not available in all countries.

Model: Quickie Q200R



Maximum occupant mass:
Q200R 136kg user.

The wheelchair Quickie
Q200R conforms to the
following standards:

a) requirements and test
methods for static, impact
and fatigue strengths
(ISO 7176-8)

b) power and control
systems for electric
wheelchairs requirements
and test methods (ISO
7176-14)

c) climatic test in
accordance with ISO
7176-9

d) requirements for
resistance to ignition in
accordance with
ISO 7176-16

e) the product is specified
as a Class B power chair

f) all materials used on
this product conform to
EN1021 parts 1 and 2.

ISO 7176-15	Min	Max	Comments
Overall length (with legrest)	1070mm	1160mm	
Overall width powerbase	-	580mm	
Overall width seat	540mm	580mm	Armrests in / out
Folded length	-	830mm	
Folded height	640mm	680mm	
Total mass (w/batteries)	-	98kg	
Mass of the heaviest part	-	17kg	Battery
Mass of removable armrest	1.8kg	2.7kg	Without / with joystick
Static stability downhill	15°	-	
Static stability uphill	15°	-	
Static stability sideways	15°	-	
Energy consumption (Max. range)	31km	29km	6km/h - 10km/h
Dynamic stability uphill	8°	12°	Least / most stable seat
Obstacle climbing	-	100mm	10km/h (67mm - no KC)
Maximum speed forward	6km/h	10km/h	
Min. braking distance from max. speed	1000mm	2100mm	6km/h - 10km/h
Seat plane angle	0°	6°	3 positions
Effective seat depth	410mm	510mm	5 positions
Effective seat width	430mm	500mm	
Seat surface height at front edge	450mm	490mm	Cushion removed
Backrest angle	0°	12°	4 positions
Backrest height	-	500mm	Cushion removed
Footrest to seat distance	330mm	480mm	Basix type hanger *
Leg to seat surface angle	65°	90°	Adjustable footplate
Armrest to seat distance	220mm	300mm	Cushion removed
Front location of armrest structure	385mm	460mm	
Minimum turning radius	850mm	-	
EN 12184	Min	Max	Comments
Maximum height of kerb safely descend	-	100mm	
Minimum width of corridor	1150mm	-	
Minimum ground clearance	95mm	-	50mm at anti-tips
Speed control operation force	-	1,8 N	
Direction control operation force	-	1,5 N	

NOTE: Some of the options and measures may be not available in all countries.

17.0 Service Advice-Service History:

This section is designed to assist you in keeping a record of any service and repairs to your wheelchair. The service Agent will complete this section and return the manual to you.

NOTE: Please contact your local Sunrise medical approved servicing agent for any warranty, service or repair work required.

Model				
Serial Number				
Year	1	2	3	4
Service dates				
Controller				
On/Off switch				
Output plug				
Operation				
Dynamic braking				
Programmable configuration				
Batteries				
Physical Damage				
Connections				
Discharge tests				
Wheels/Tyres				
Wear				
Pressure				
Bearings				
Whel nuts				
Motors				
Wiring				
Noises				
Connections				
Brakes				
Brushes				
Freewheel Device				
Chassis				
Condition				
Steering				
Upholstery				
Seat				
Back				
Armrests				
Electric's				
Condition of loom				
Connections				
Test run				
Forward				
Reverse				
Emergency stop				
Left run				
Right run				
Up/Down slope				
Over obstacle				
Parking brake				

Servicing Agents Only:

Any parts required should be obtained from Sunrise Medical only either through our web site or by direct contact with our Customer Service or Service department. Do not used unauthorized parts or carry out unauthorised modifications.

18.0 Performance checks:

After performing any maintenance or repairs on the wheelchair you must make sure that it is functioning correctly before it is used.

- Visually inspect the wheelchair to make sure the legrests, armrests etc are correctly positioned and attached to the wheelchair and all fasteners are sufficiently tightened.
- Make sure that the backrest is correctly fitted and adjusted.
- Make sure that all of the cushions are in place.
- Switch on the hand control – Do the lights flash? This signifies that there is a fault in the electronic system. Refer to section 8.0 for basic troubleshooting.
- Perform the parking brake check.
- Operate all of the electric options, including lights and indicators (if fitted) to make sure that they work correctly.
- Drive the wheelchair in each of the drive profiles, (if installed), to make sure the wheelchair performs as it did before.

WARNING!

If you are in any doubt about the performance requirements of your wheelchair contact your Sunrise Medical authorised dealer.

NOTE: Only the tasks in the GREEN boxes below should be attempted by the user. If you are in any doubt, please contact your Sunrise Medical authorised dealer.

18.1 Re-use

Due to its construction the Q100R/Q200R is ideal for inside use (low seat height, compact dimensions) as well as outside use, (lights, 55Ah batteries, etc.).

Its high level of flexibility, due to the number of possible adjustments, and the modular platform technology (modular construction system) make the Q100R/Q200R ideal for re-use.

Individual modules (seat tilt in space, backrest angle adjustment) can be fitted and removed very quickly and within the seating system there are a range of possibilities so that individual adjustments can be made to suit the end user.

Optional mounting of the operating unit on the left or right side of the chair, with the possibility of changing later, and adjustable distance from the backrest.

Maintenance and Inspection Schedule	Daily	Weekly	Quarterly	Six month	Annually
Check battery level indicator and charge if necessary.	*				
Check the joystick of the hand control is not bent or damaged.	*				
Ensure all removable parts / wing screws are securely fastened.	*				
Check lapstrap for wear and make sure the buckle is operational.	*				
Parking brake test.		*			
Check tyres and inflate.		*			
Ensure the fasteners on the seat depth adjustment are tight,		*			
Ensure all cables and connectors are sound and are tidy and out of the way.		*			
Clean wheelchair and upholstery.		*			
Battery terminal inspection – Remove any corrosion and apply Vaseline.			*		
Check upholstery, seating, headrests, armpads and calfpads for wear.				*	
Complete inspection, safety check and service should be made by a Sunrise Medical authorised dealer.					*



UK = www.SunriseMedical.co.uk

DE = www.SunriseMedical.de

FR = www.sunrisemedical.fr

IT = www.SunriseMedical.it

NL = www.SunriseMedical.nl

ES = www.SunriseMedical.es

PT = www.SunriseMedical.pt

SE = www.SunriseMedical.se

NO = www.SunriseMedical.no

DK = www.SunriseMedical.dk

CH = www.SunriseMedical.ch

CZ = www.medicco.cz

PL = www.Sunrise-Medical.pl

EU = www.SunriseMedical.eu

AU = www.sunrisemedical.com.au

US = www.SunriseMedical.com

