



Quickie Jive

Instructions for Use



000690669.00

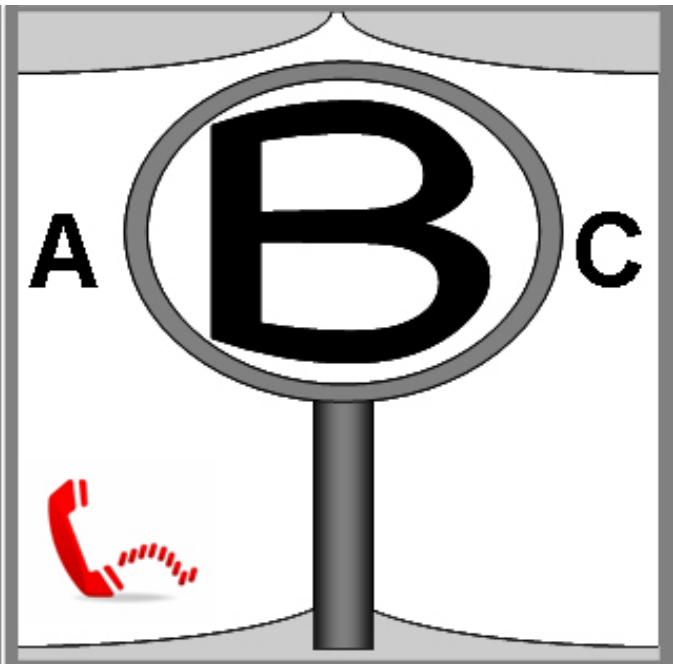

IF YOU ARE VISUALLY IMPAIRED, THIS DOCUMENT CAN BE VIEWED IN PDF FORMAT AT WWW.SUNRISEMEDICAL.COM OR ALTERNATIVELY IS AVAILABLE ON REQUEST IN LARGE TEXT.

FOR FURTHER INFORMATION ON THE FULL SPECIFICATION AND OPTIONS AND ACCESSORIES PLEASE REFER TO THE ORDER FORM. ALL INFORMATION IS SUBJECT TO CHANGE WITHOUT NOTIFICATION. PLEASE CONSULT SUNRISE MEDICAL WITH ANY QUERIES YOU MAY HAVE.

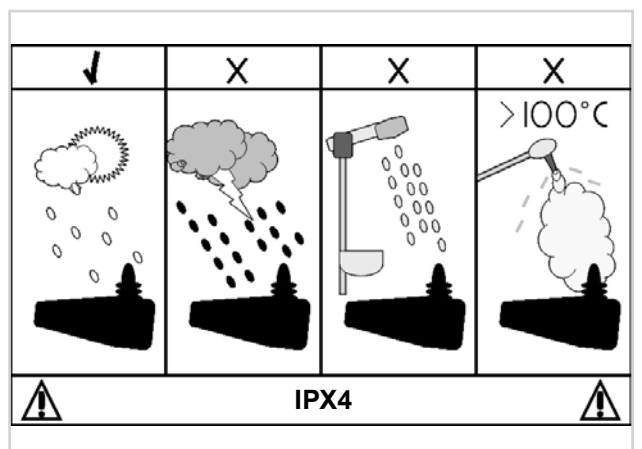
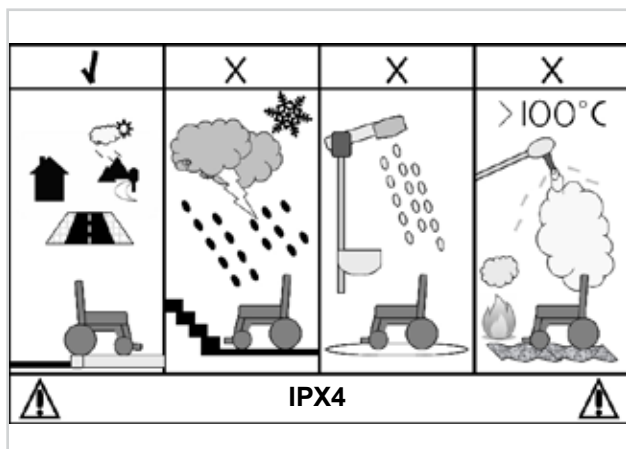
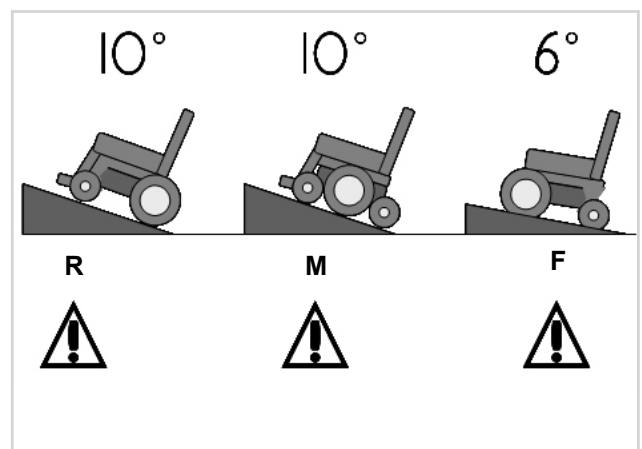
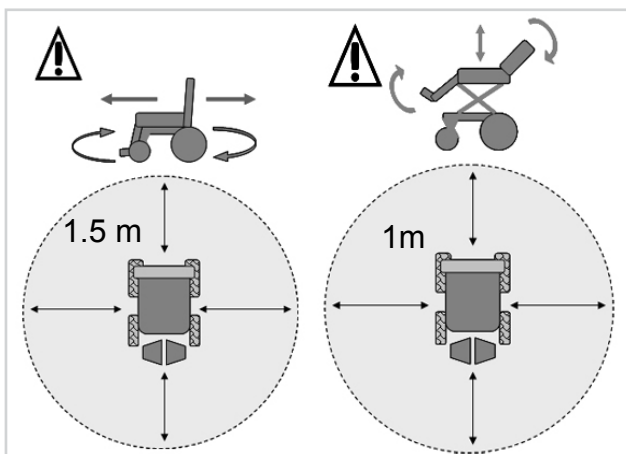

User Information

Intended use power wheel chairs:

Power wheelchairs are exclusively for a user who is unable to walk or has limited mobility, for their own personal use indoors and outdoor.

When an Attendant Control Module is fitted, the Power Wheelchair may be operated by an assistant on behalf of the user.

When a Dual Control Module is fitted the Power Wheelchair may be operated by the user, or control may be switched to an assistant to operate on behalf of the user.

The maximum weight limit (includes both the user and any weight of accessories fitted to the wheelchair) is marked on the serial number label, which is affixed to the chassis of the chair.

The chair serial number is affixed also to the front page of the owners manual supplied with the wheelchair.

Warranty can only be taken on if the product is used under the specified conditions and for the intended purposes.

The intended lifetime of the wheelchair is 5 years. Please DO NOT use or fit any 3rd party components to the wheelchair unless they are officially approved by Sunrise Medical.

Area of application

The variety of fitting variants as well as the modular design mean that it can be used by those who cannot walk or have limited mobility e.g. because of:

- Paralysis
- Loss of extremity (leg amputation)
- Extremity defect deformity
- Joint contractures/joint injuries
- Strokes and brain injuries
- Neurological disabilities (e.g. MS, Parkinson...)
- Illnesses such as heart and circulation deficiencies, disturbance of equilibrium or cachexia as well as for elderly people who still have the strength in the upper body.
- Persons who are mentally and physically able to control an input device to operate the chair and its functions in a safe way.

When considering provision, please also note the body size, weight including the distribution of body weight, the user's physical and psychological constitution, the age of the user, their living conditions and their environment. If in doubt a health care professional should be involved to ensure the user is not exposed to unacceptable risks.

Sunrise Medical is ISO 9001 certified, which ensures quality at all stages of the development and production of this wheelchair.



WARNING!



DO NOT USE YOUR WHEELCHAIR UNTIL THIS MANUAL HAS BEEN READ AND UNDERSTOOD.



Sunrise Medical declares under its sole responsibility that this product is in conformity with the requirements of the directive 93/42/EEC amended by 2007/47/EEC."

Sunrise Medical declares that this product fulfils the performance requirements for a "Crash Test" to ISO 7176-19.

The Serial Number and other important information may be found on a label situated on the right-hand side, main frame of the product.

The JIVE has been designed for use by an individual on a daily basis. It is suitable for both indoor and outdoor use (Class B). It is intended for use on walk ways and/or roads depending on the configuration, but may always be used when crossing between walk ways*.

**The use of the JIVE on walk ways and roads may be subject to the applicable legal requirements of National Road Laws and or Road Traffic Laws*

Mid Wheel Drive (MWD)

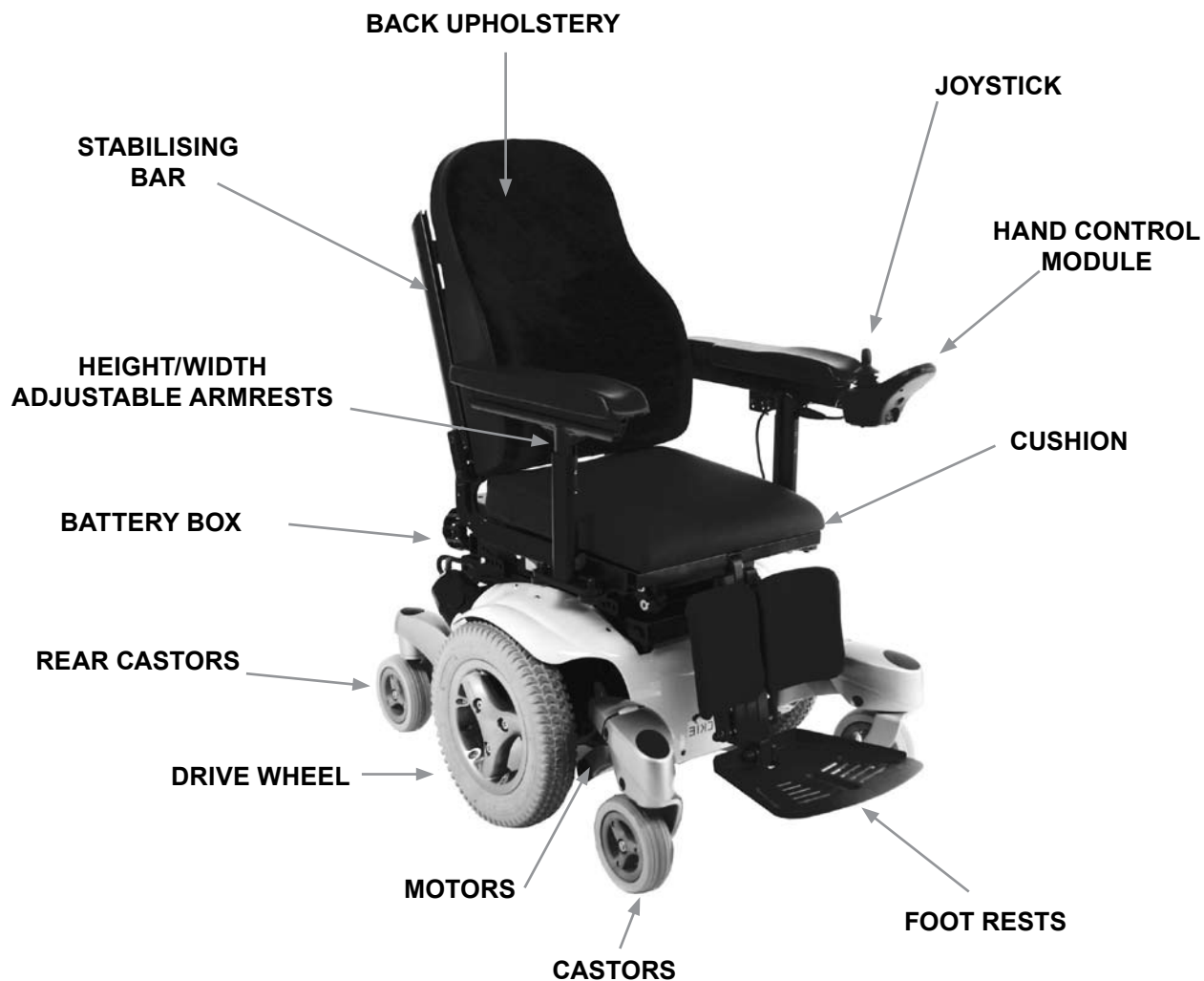

Due to its modular design, simplicity and wide range of adjustments, the Quickie Jive is a perfect choice for easy service, refurbishment and recycle requirements.

As a part of our ongoing product improvement initiative, Sunrise Medical reserves the right to change specifications and design without notice. Further, not all features and options offered are compatible with all configurations of the wheelchair.

All dimensions are approximate and may be subject to change.

Rear Wheel Drive (RWD)

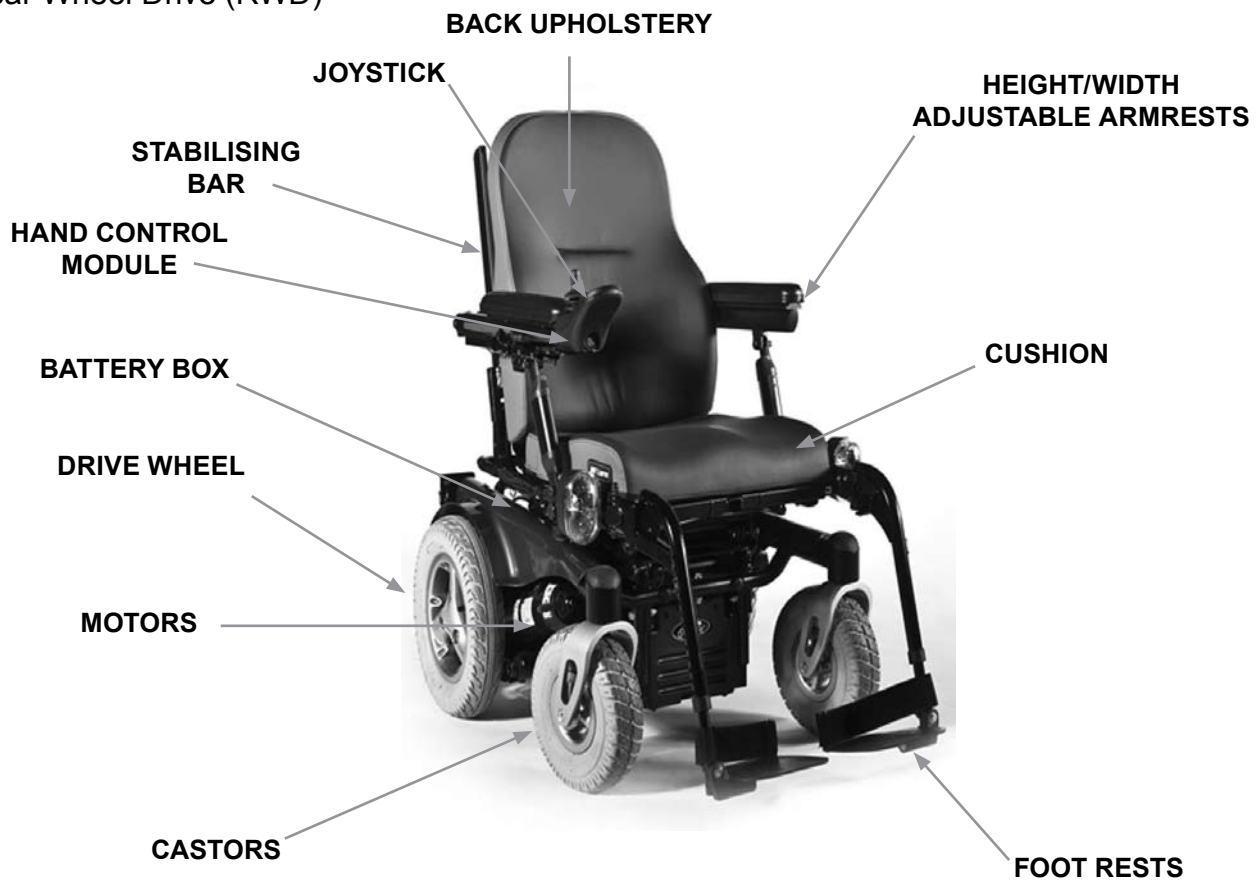

Front Wheel Drive (FWD)

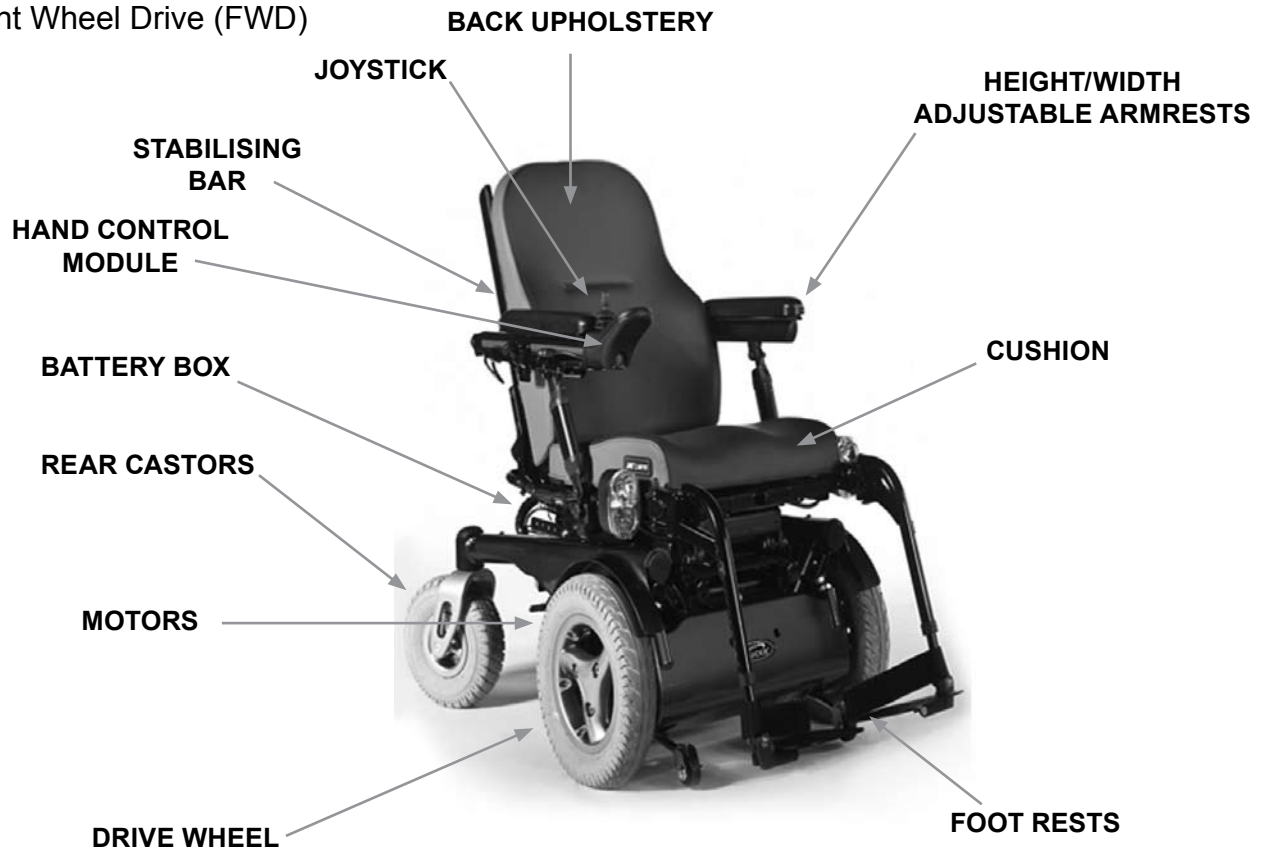

1.0 Your Wheelchair	7		
2.0 How to use this manual:	7		
2.1 Introduction:	7		
2.2 Guarantee:	7		
2.3 Warranty-Repair-Service conditions:	7		
2.4 Label explanations	8		
3.0 Label Explantation / Word definitions	8		
3.1 Definitions of words used in this manual	8		
4.0 General safety warning and user tips	10		
4.1 General warnings	10		
4.2 Features and options	10		
4.3 Kerbs	10		
4.4 Routine service	10		
4.5 Emergency freewheel	10		
4.6 EMC - Radio transmitting devices.	10		
4.7 Emergency braking	10		
4.8 Sharp turns	11		
4.9 Batteries	11		
4.10 Tyres	11		
4.11 Weight limit	11		
4.12 Wheelchair motors	11		
4.13 Wheelchair range	12		
4.14 Road use	12		
4.15 Adverse conditions	12		
4.16 Ramps	12		
4.17 Transfer to and from the chair	12		
4.18 Lift and tilt modules	12		
4.19 Anti tips	12		
4.20 Use on a slope	13		
4.21 Gradients: ascents	13		
4.22 Gradients: descents	13		
4.23 Using a vehicle mounted passenger lift	13		
4.24 Creep mode	13		
4.25 Stability of your wheelchair	14		
4.26 Seat stay pin	14		
4.27 Wheels	14		
4.28 Rear view mirror	14		
4.29 Crutch holder	14		
4.30 Lights and indicators	15		
4.31 Vent tray	15		
4.32 Swing away tray	15		
4.33 Using a kerb climber	15		
4.34 Lap strap	17		
5.0 Preparing your wheelchair for use	18		
5.1 Handling the wheelchair	18		
5.2 Preparation for transportation or storage	18		
5.3 Re-Assembling	18		
5.4 Emergency freewheel	18		
5.5 Drive wheel suspension Jive F/R	19		
5.6 Control joystick unit position	19		
5.7 Arm Rests	19		
5.8 Leg Rests	20		
6.0 Seating	22		
6.1 Seat cushions	22		
6.2 Changing seat depth on the standard rehab seat	22		
6.3 Changing seat height	23		
6.4 Removable seat covers	23		
6.5 Backrest, folding for transport	23		
6.6 Manual angle adjustment of the fixed back	23		
6.7 Manual adjustable backrest (manual recline)	24		
6.8 JAY backrests	24		
6.9 Headrest	24		
6.10 Manual setting of the seat angle on the Jive	24		
6.11 Powered Seating	24		
7.0 VR2 Control System (Fig.7.1):	26		
7.1 On/Off button:	26		
7.2 Battery Level Indicator:	26		
7.3 Locking/unlocking the wheelchair:	26		
7.4 Operating the control joystick:	27		
7.5 Maximum speed/profile indicator:	27		
7.6 The horn button:	27		
7.7 Speed/Profile decrease button:	27		
7.8 Speed/Profile increase button:	27		
7.9 Actuator button and LEDs:	27		
7.10 VR2-L	28		
7.11 Charging and programming socket:	29		
7.12 VR2 dual control unit:	29		
7.13 Control button and indicator:	29		
7.14 Actuator button and LED:	29		
7.15 Maximum speed button and indicator:	30		
7.16 Quickie Direct Actuator Control Box:	30		
8.0 Troubleshooting The VR2 Hand Control:	30		
9.0 R-net Control System	32		
9.1 R-net control system information	32		
10.0 Controller Mounts	33		
10.1 General warnings	33		
10.2 Parallel swing-away general warnings, (Fig.10.1)	33		
10.3 Attendant control, (Fig.10.2)	33		
10.4 Centre bar mount control (R-net)	34		
10.5 Tray mount control (R-net)	34		
10.6 Swing-away tray mounted centre control (R-net)	34		
10.7 Forus control (R-net)	34		
10.8 Powered swing away arm (R-net)	35		
11.0 Speciality Controls	36		
11.1 Proximity head array	36		
11.2 Driving with the head array (Fig 11.1)	36		
11.3 Proportional head control	36		
11.4 Sip and puff control and buddy buttons	37		
11.5 HMC mini joystick as a chin control or hand control	37		
11.6 Proportional chin control (Fig.11.8)	37		
11.7 Micro pilot Joystick	37		
12.0 Batteries and charging	38		
12.1 Batteries	38		
12.2 Safety cut-outs	38		
12.3 Common battery statements	38		
12.4 Maintenance free batteries	39		
12.5 Battery care	39		
12.6 Maintenance free battery care plan	39		
12.7 General charger information	39		
12.8 The range of your vehicle	41		
12.9 Battery warranty	41		
13.0 Transportation	42		
13.1 Transportation Warnings	42		
13.2 Occupant Restraint Instruction:	44		
13.3 Positioning of the Tie Down Restraints:	44		
13.4 Leg Strap Fitting Instructions Adjustable Hangers	46		
13.5 Special shipping requirements:	46		
13.6 Medium to long term storage:	46		
14.0 Maintenance and Cleaning	47		
14.1 Tyre maintenance and pressures	47		
14.2 Removing the MWD castor wheel.	49		
14.3 Removing the RWD/FWD castor wheel.	50		
14.4 Cleaning and your wheelchair	51		
14.5 Lighting bulb exchange procedure	52		
14.6 Electrical connections	52		
14.7 How to connect the cables to the batteries	53		
14.8 Controller access	54		
14.9 Storage	54		
14.10 Authorised Sunrise Medical service agents	54		
14.11 Recommended maintenance routines	54		
15.0 Specification sheets	56		
15.1 Model: Quickie Jive R	56		
15.2 Model: Quickie Jive F	57		
15.3 Model: Quickie Jive M	58		
16.0 Service History	59		
17.0 Disposal	59		

1.0 Your Wheelchair

We at Sunrise Medical want you to get the best out of your JIVE wheelchair. This Owner's Manual will familiarise you with the chair and its features. It contains hints on everyday usage and general care in addition to information on the high quality standards which we adhere to and details about the guarantee.

Your wheelchair should be delivered fully configured for your use; there are a wide range of components and adjustments available on the JIVE. For further information about these you should contact your Sunrise Medical authorised dealer.

Your wheelchair will reach you in excellent condition having been personally inspected before leaving our factory. Following the guidelines for maintenance and cleaning your wheelchair will maintain its first class condition and give you complete satisfaction. The JIVE has been designed for use by an individual on a daily basis. It is suitable for both indoor and outdoor use (Class B). It is only intended for use as a pavement vehicle, but may also be used when crossing between pavements.

This vehicle has been designed for a single occupant of limited mobility who has the cognitive, physical and visual ability to control the vehicle safely. The JIVE R, JIVE F & JIVE M have a maximum user weight up to 160Kg (dependant on options chosen for your chair). The JIVE R & JIVE M have a maximum slope handling of 18% (10°). The JIVE F- XL, has an increased maximum user weight of 240Kg. The JIVE F and JIVE F-XL, has a maximum slope handling of 10%. (6°). If you are in any doubt as to the suitability of the power chair, contact your local Sunrise Medical approved supplier for clarification, prior to commencing use.

It is very important to read the relevant section of the owner's manual when making any minor adjustments. Consult the Technical Manual or your local Sunrise Medical authorised dealer for more complex adjustments.

If you have any queries about the use, maintenance or safety of your wheelchair, please contact your local approved Sunrise Medical service agent. If you do not know of an approved dealer in your area or have any other questions please write or telephone:

Sunrise Medical LTD.
Sunrise Business Park
High Street, Wollaston
West Midlands DY8 4PS
England

Phone: +44 (0) 1384 44 66 88

Fax: +44 (0) 1384 44 66 99

2.0 How to use this manual:

2.1 Introduction:

Please keep a note of your local service agent's address and telephone number in the space below.

In the event of a breakdown, contact them and try to give all relevant details so they can help you quickly.

The wheelchairs shown and described in this manual may not be exactly the same in every detail as your own model. However, all instructions are still entirely relevant, irrespective of detail differences.

NOTE: The manufacturer reserves the right to alter without notice any weights, measurements or other technical data shown in this manual. All figures, measurements and capacities shown in this manual are approximate and do not constitute specifications.

2.2 Guarantee:

The guarantee form is included in the Sunrise Pack. Please fill in the relevant details and return to us to register your entitlement.

THIS IN NO WAY AFFECTS YOUR STATUTORY RIGHTS.

2.3 Warranty-Repair-Service conditions:

1) The repair or replacement will be carried out by an authorised Sunrise Medical dealer/service agent.

2) To apply the warranty conditions, should your wheelchair require attention under these arrangements, notify the designated Sunrise Medical service agent immediately giving full information about the nature of the difficulty. Should you be operating the wheelchair away from the locality of the designated Sunrise Medical service agent, work under the "Warranty Conditions" will be carried out by any other service agent designated by the manufacturer.

3) Should any part of the wheelchair require repair or replacement, as a result of a specific manufacturing or material defect, within **twenty four months** from the date on which the possession of the wheelchair was transferred to the original purchaser, and subject to it remaining within that ownership, the part or parts will be repaired or replaced completely free of charge if returned to the authorised service agent.

If you are unsure who your local servicing agent is: Please contact Sunrise Medical using the contact details opposite.

Dealer signature and stamp

4) Any repaired or replaced part will benefit from these arrangements for the balance of the warranty period applicable to the wheelchair.

5) Parts replaced after the original warranty has expired are covered for a further twelve months.

6) Items of a consumable nature will not generally be covered during the normal warranty period, unless such items have clearly suffered undue wear as a direct result of an original manufacturing defect. These items include amongst others upholstery, tyres, inner tubes and similar parts. On powered products this will also include batteries, motor brushes etc

7) The above warranty conditions apply to all wheelchair parts for models purchased at full retail price.

8) Under normal circumstances, no responsibility will be accepted where the wheelchair has required repair or replacement as a direct result of:

a) The wheelchair or part not having been maintained or serviced in accordance with the manufacturer's recommendations, as stated in the Owner's Manual and/ or Service Manual. Or failing to use only the specified original equipment parts.





b) The wheelchair or part having been damaged by neglect, accident or improper use.

c) The wheelchair or part having been altered from the manufacturer's specifications, or repairs having been attempted prior to the service agent being notified.

2.4 Label explanations

3.0 Label Explanation / Word definitions

3.1 Definitions of words used in this manual

Word	Definition
 DANGER!	Advice to the user of Potential Risk of serious injury or death if the advice is not followed
 WARNING!	Advice to the user of a potential risk of injury if the advice is not followed
 CAUTION!	Advice to user that potential damage to equipment may occur if the advice is not followed
NOTE:	General advice or best practice
RWD	Rear Wheel Drive
FWD	Front Wheel Drive
MWD	Mid Wheel Drive
	Reference to a related document
	Information

⚠ WARNING!

- * BATTERIES CONTAIN ACID AND CAN EXPLODE. ALWAYS WEAR EYE PROTECTION WHEN WORKING NEAR BATTERIES.
- * ALWAYS KEEP BATTERY TERMINALS AND CLAMPS CLEAN AND FREE OF CORROSION.
- * ALWAYS CHARGE BATTERIES IN WELL VENTILATED AREA, AWAY FROM SPARKS AND FLAME.
- * NEVER ALTER BATTERY WIRING OR BATTERY BOX.
- * NEVER ALLOW TOOLS TO MAKE CONTACT ACROSS TERMINALS.
- * NEVER USE BATTERIES OR CLAMPS WITH WING NUT TERMINALS, OR CLAMPS THAT EXCEED TERMINAL POST HEIGHT.

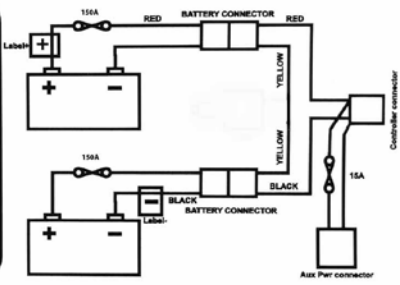

Battery Label – Warning Instructions and Circuit Diagram









Lever position for the Left-hand freewheel mechanism.
OUT – disengaged IN - engaged



Lever position for the Right-hand freewheel mechanism.
OUT – disengaged IN - engaged

Labels and their descriptions

	
<p>Warning - Do Not Touch - HOT</p>	<p>WARNING – Ensure the seat interface quick release is screwed in tight before using your wheelchair, especially on a slope</p>
	
<p>Attached to Joystick WARNING – Do not drive your wheelchair on a slope with the backrest reclined and/or the seat lifted</p>	<p>WARNING – Maximum user weight for the chair (will be either 240Kg, 160Kg or 137Kg depending on the options, Kerb climbing and model chosen)</p>
	
<p>WARNING – Danger of finger entrapment</p>	<p>WARNING – When the seat is raised, ensure the spring pin clicks back into the lock position to hold the seat upright.</p>

4.0 General safety warning and user tips

4.1 General warnings



WARNING!

- Always ensure that your wheelchair is switched off before attempting to mount or dismount.
- Always ensure that you are able to operate all controls from a comfortable position. Paying attention to your posture is essential to ensure your continued comfort and well being.
- Always make sure that you can be seen clearly, especially if you intend using your wheelchair in poor light.
- This wheelchair has been built to match the needs of a particular user. If used by another user then it may need to be adjusted and reprogrammed.
- Do not let children or others use your wheelchair.

4.2 Features and options

NOTE: Some of the options shown in this manual may not be available in your country and may also restrict the overall physical limits of the standard product (e.g. max. speed, user weight limit, etc.). Those limitations are marked on the order form, in the technical manual and in this owner's manual. For further information please consult your Sunrise Medical authorised dealer.

4.3 Kerbs



DANGER!

- Never descend a kerb Forwards with a RWD chair or Backwards with a FWD and MWD chair. Please read carefully the section 4.33 on kerb climbing in this manual before attempting to mount and dismount any kerbs in your wheelchair.
- Do not attempt to climb or descend a series of steps. It is unsafe to do so and could cause personal injury or damage the chair. The Jive has only been designed to climb a single step or kerb.
- We recommend that users with upper trunk instability wear further customised restraint systems to keep the upright body position during descending or ascending ramps, curbs or obstacles.

4.4 Routine service

The recommended service interval is one year. (See service history table in section 16).

4.5 Emergency freewheel



DANGER!

- Please remember that you have no braking facility when the freewheel levers are moved from the normal drive position to the freewheel position (Fig. 4.1). Always ensure an attendant is with you when bringing the chair into the freewheel mode.
- The wheelchair must never be left with one or both levers in the freewheel position. For an enhanced description of this facility and its limitations to use please see later section at 5.4.



4.6 EMC - Radio transmitting devices.



WARNING!

- When operating two-way radio, walkie-talkies, C.B., amateur radio, public mobile radio and other powerful transmitting devices the wheelchair should be brought to a halt and turned off.
- The operation of cordless, mobile telephones and cell phones including hands-free devices is permitted but if abnormal operation of the wheelchair is encountered then the chair must be brought immediately to a halt and turned off.

NOTE: the electrical systems of the wheelchair may disturb the performance of alarm systems in retail shops.

4.7 Emergency braking

There are three ways to stop your wheelchair:

1. Simplest and safest way to stop the wheelchair is to release the joystick (see Hand Control section 7). This will bring the chair to a halt in a controlled manner.
2. Pulling back the joystick will brake the chair abruptly with a fast stop
3. Switching the control system off whilst the chair is in motion will also bring the chair to a halt.



WARNING!

This third method is only to be used in an emergency situation as the stopping action is very abrupt.

4.8 Sharp turns

 **DANGER!**

Full speed turns should not be attempted. If you need to turn sharply you must reduce your speed with the joystick or speed setting. This is particularly important when travelling across or down a slope. Disregarding this advice could lead to your wheelchair tipping over.

4.9 Batteries

Your wheelchair is supplied as standard from Sunrise Medical with maintenance-free batteries. These only require regular charging. Before charging, please read section 12 in this manual.

 **WARNING!**

Do not, under any circumstances, tamper with the batteries. If in any doubt contact your local Sunrise Medical authorised dealer.

 **CAUTION!**

Before using your vehicle for the very first time, please charge your batteries for a period of 24 hours.

 **WARNING!**

Avoid contact with acid on damaged sealed type batteries or wet batteries. Battery acid can cause burns to the skin as well as damage to floors, furniture and your wheelchair. If it comes into contact with the skin or clothing, wash immediately with soap and water. If it comes into contact with the eye, immediately flood the eye with running cold water for at least 10 minutes and seek medical attention immediately. Acid can be neutralised with baking soda and water. Take care to keep batteries upright at all times, especially when transporting your wheelchair.

Battery and charger type:

24V (2x12V) / 73 Ah/20h. Maintenance free
Dimensions: 260 x 171 x 210 mm.

24V (2x12V) / 60 Ah/20h. Maintenance free
Dimensions: 256 x 169 x 178 mm.

Connector: 3 pins "Neutrik" type (polarity scheme in section 17)

4.10 Tyres

Your wheelchair tyres can wear depending on use. Check them regularly in accordance with the service instructions in this manual, especially the pressure of the tyres.

 **DANGER!**

Never inflate the tyres using a garage forecourt airline, always use the pump provided.

4.11 Weight limit

 **DANGER!**

- The user plus items carried should never exceed a total weight of 160Kg or 137Kg if fitted with a kerb climber. This figure rises to 240Kg for the Jive F-XL.
- Never use this chair for weight training if the total weight (user plus additional weights) exceed a total weight of 160Kg or 137Kg if fitted with a kerb climber, (240Kg for the Jive F-XL).
- Exceeding the weight limit is likely to damage the seat, frame or fasteners and may cause severe injury to you or others from chair failure
- Exceeding the weight limit will void the warranty.

4.12 Wheelchair motors

After prolonged use, the motors will produce heat, which is radiated through the motors' outer casing.

 **WARNING!**

Do not touch the motors' outer casing for at least 30 minutes after using the wheelchair, to allow it to cool. (Fig. 4.2).



 **WARNING!**

Hot surfaces

Not only the motors can get hot during the operation of the chair, but also the upholstery material and armrests when standing in the sun.

4.13 Wheelchair range

The range of your wheelchair can be affected by many factors such as user weight, terrain, ambient temperature, use of powered options and battery condition.

NOTE: The stated range in the sales literature should be seen as the theoretical maximum (ISO 7176; Part 4) and may not be attained by every user (also see section 12.8 in this manual).

We recommend that every user initially limit their journey to half the stated range, until they have confidence in the actual range their wheelchair can attain.

CAUTION!

If your battery indicator is showing a low charge then do not attempt a long journey unless you are confident in reaching your destination and also returning to your home without the risk of being left stranded.

4.14 Road use

Please show the utmost consideration for the other traffic on the road.

DANGER!

Remember that the last thing a car or lorry driver expects to see is a wheelchair backing off the kerb into the road. If in any doubt, do not risk crossing the road until you are certain that it is safe. Always cross the road as quickly as possible; there may be other traffic.

4.15 Adverse conditions

Please be aware that when driving your wheelchair in adverse conditions, e.g. on wet grass, mud, ice, snow or other slippery surfaces, you may experience a reduction in the grip and traction of your wheelchair.

WARNING!

We recommend you take extra precautions in these conditions, particularly on hills and slopes; your wheelchair could become unstable or skid causing possible injury.

NOTE: Extreme variances in temperature may trigger the self protect mechanism in the control system. If this occurs the control system will temporarily shut down to prevent damage to the electronics or the chair.

4.16 Ramps

WARNING!

When using a ramp, please ensure that it is capable of taking the combined weight of the power chair and yourself. If a ramp is being used to load a chair into a vehicle, please ensure the ramp is properly secured to the vehicle.

Always approach the ramp head-on and exercise caution.

CAUTION!

Please ensure your ramp is suitable for the product you are transporting.

4.17 Transfer to and from the chair

WARNING!

Sunrise Medical recommend that you consult your healthcare professional for assistance in developing your personal front or side transfer technique to best suit your needs and avoid any personal injury.

WARNING!

Ensure controller is switched off during transfers to avoid unintentional movement.

4.18 Lift and tilt modules

WARNING!



Please be aware that the lift and tilt modules present a trap hazard. Make sure that when operating the tilt and lift it is free from all clothing, hands, feet and other extremities to prevent injury.

Do not drive on ramps or slopes with the seat tilted, reclined or raised. Before attempting to climb or decline a slope, return to an upright position

4.19 Anti tips

CAUTION!

Make sure that anti tips are not damaged or worn before using your chair.

Check the anti tips are functioning correctly on a regular basis.

WARNING!

Attendants must be aware of the location of the RWD anti tips to prevent feet being trapped underneath causing injury

Attendants - Do not stand on the anti tips, this could cause the wheelchair to become unstable.

4.20 Use on a slope

Your wheelchair has been designed and tested to allow its use on slopes or gradients of up to 10° (18%) in RWD/MWD configuration and 6° (11%) in FWD configuration. However, you have the option of adjusting your seating position with either a lift, tilt or recline or a combination of these options.

WARNING!

In certain circumstances your wheelchair could become unstable. Before attempting to climb or descend a slope or a kerb, caution should be taken when using weight shift options (e.g. powered tilt or recline), of the seat and/or your body for a counter balance weight.

To improve stability lean forward when driving uphill, with the seat and back in an upright position.

Alternatively sit in an upright position when travelling in a forward, downhill direction or tilt and/or recline the seat backwards.

When driving downhill with a FWD chair reduce your speed below 5kph. This prevents the chair from going onto the front anti-tip wheels when decelerating.

WARNING!

We strongly recommend that you return the seat and back to an upright lowered position before attempting to climb or descend a slope. Failure to do this may cause the wheelchair to become unstable.

WARNING!

If you are in any doubt about the capabilities of your wheelchair on a slope then do not attempt to drive up or down the slope/kerb; try to find an alternative route.

4.21 Gradients: ascents

WARNING!

- When going uphill, keep the chair moving.
- Steer by carefully moving the joystick forwards making slight Left and Right adjustments as you go.
- If you have stopped on a hill, you should start slowly.
- On a RWD chair, if necessary lean forward to prevent the tendency for the front wheels to lift.

4.22 Gradients: descents

On descents, it is important not to let the wheelchair accelerate beyond its normal level of ground speed.

WARNING!

Proceed slowly down steep descents, (below the speed of 5kph) and stop if any anxiety arises regarding directional control.

If the chair picks up speed, centre the joystick to slow it or to stop all forward movement, then restart slowly and do not allow the speed to increase.

NOTE: The solid state controller has the benefit of a logic system that will help compensate when driving along a camber or up a hill. This is an added safety feature on your wheelchair. In addition of course, you may control the wheelchair speed by using the speed control.

4.23 Using a vehicle mounted passenger lift

Wheelchair lifts are used in vans, buses and buildings to help you move from one level to another.

DANGER!

- Ensure that the user and all carers fully understand the lift manufacturer's instructions for using the passenger lift.
- Never exceed the lift manufacturer's recommended safe working load and load distribution guidance.
- Always turn off all power when you are on the lift. If you fail to do so, you may touch the joystick by accident and cause your chair to drive off the platform. Be aware that a rollstop at the end of the platform may not prevent this.
- Always position the user securely in the chair to help avoid falls while on the lift.
- Always ensure the chair is in drive mode when using passenger lift (wheels locked not in freewheel mode).

4.24 Creep mode

WARNING!

Please ensure your backrest recline angle relative to floor level, (which is a combination of the back recline itself and the tilt angle), does not exceed 12° to drive the chair safely.

NOTE: If your wheelchair is fitted with a Lift/Tilt module, you will go into 'Creep Mode' as soon as the seat is lifted.

WARNING!

If you have Recaro seating or a manual recline backrest on your wheelchair, please be aware that there will be no feedback system to the controller that tells it that the seat is in a reclined position. If you recline your backrest and attempt to drive, it will not go into 'creep mode', it will instead drive at full speed.

DANGER!

This is especially dangerous when attempting to drive up a slope.

4.25 Stability of your wheelchair

Please follow the user instructions in this manual regarding the use of seat lift and tilt modules and the use of your chair on a slope.

WARNING!

Other variables can affect your chair stability, including:

Movement of the user
Effects of the addition of accessories or other equipment
Inappropriate adjustments or modifications to the wheelchair

In some cases these issues are further compounded by the effects of the local environment such as:

- Hills
- Slopes
- Ramps
- Sloping/uneven footpaths
- Dropped kerbs

Furthermore different body proportions of a wheelchair user affect stability for example:

- Lower limb wasting or amputation
- Increased upper torso mass
- Upper torso height
- Obesity

4.26 Seat stay pin

A seat stay pin is provided on your powerchair to provide access for service and maintenance. When the seat is raised, ensure the spring pin clicks back into the lock position to hold the seat upright.

WARNING:

Do not move the wheelchair with the seat stay pin in place and make sure you are on flat stable ground. Make sure that the pin is retracted before lowering the seat.

4.27 Wheels

DANGER!

Always use the pump that is supplied with the chair, Never use a forecourt pump.

Inspect all tyres regularly for signs of wear.

Do not drive over anything that could cause punctures in the tyres.

Ensure that there are no objects in your path that could possibly become lodged in your chair mechanism or in the spokes of the rear wheels. This could cause the chair to come to a sudden stop.

Riding over drains or grids could cause the wheelchair castors or wheels to become lodged, causing the chair to come to a sudden stop.

Always maintain the correct pressure for the tyre. These are listed in section 13 of this manual.

4.28 Rear view mirror

WARNING!

To avoid injury to people around you please be aware that the mirror protrudes outside the space envelope of the chair and could cause injury to someone when driving past.

The mirror must be used on the 10KPH model on UK roads.

Always make sure that when using the mirror that it is clean and unbroken so that it does not impair your visibility.

4.29 Crutch holder

WARNING!

Make sure that the crutch is securely fastened to the crutch holder.

Make sure that the crutch is not interfering with the mechanisms of the chair.

Make sure that the crutch does not protrude from the chair.

Do not attempt to remove the crutch whilst the chair is in motion.

Always come to a complete stop and turn off the power to the controls before attempting to remove the crutch. This will avoid accidentally operating the chair.

4.30 Lights and indicators

WARNING!

Ensure that the lights and indicators are functioning correctly and lens are clean before going outdoors at night.
Lights assembly can become very hot - Care must be taken if removing them for repair.

4.31 Vent tray

WARNING!

Using a vent tray will affect the stability and overall weight of your wheelchair.

Make sure that the batteries and the ventilator are securely fastened to the tray before use.
Familiarise yourself with the increased size of the wheelchair before driving to prevent potential collisions
When activating the recline backrest make sure that the area around the vent tray is clear.
Be aware that the vent tray assembly can cause a finger trap hazard when the backrest is reclined.
The vent tray is not designed to hold anything other than the vent unit and its batteries, it is not designed to hold an oxygen bottle etc. Use of these items may cause your wheelchair to become unstable.
The vent tray must be installed and maintained by a Sunrise Medical authorised dealer.

4.32 Swing away tray

WARNING!

The maximum weight allowed for the tray is 2.5kg.
Do not overload the tray, this could cause the tray to break or could cause the chair to become unstable.
Do not leave lit cigarettes or other heat sources on the tray as this could cause the tray to deform and mark.
Ensure that all extremities and clothing are free when positioning the tray for use.

4.33 Using a kerb climber

WARNING!

Always approach a kerb at 90° (Fig 4.3).

Approach the kerb (step) head on driving forwards slowly and steadily and always at a 90° angle.

RWD-Chair: As the kerb climber or castor makes contact with the kerb (step), the wheelchair should be moving slowly. Small kerbs can be climbed from a standstill.
FWD-Chair: Start accelerating the chair after a stop approx. 20cm in front of the kerb to create enough speed/torque to get the chair up.
MWD-Chair: Stop the chair as soon as the castor wheels touch the kerb.

RWD- and MWD-Chair: Apply sufficient power to the motors to lift the front of the chair up onto the kerb (step) and then apply slightly more power and speed so that the drive wheels climb the kerb (step) smoothly and without hesitation. As far as possible, keep the joystick in the straight forward position.
FWD-Chair: slow down the acceleration as soon as the drive wheels are on the kerb until the rear castor are up.

In accordance to the ground clearance, the maximum obstacle height possible to climb is 5 cm for a RWD-Chair (10 cm with kerb climber on a rear wheel drive base, Fig. 4.9, overleaf) and 10 cm for a FWD- and MWD chair, when conducted as described above.

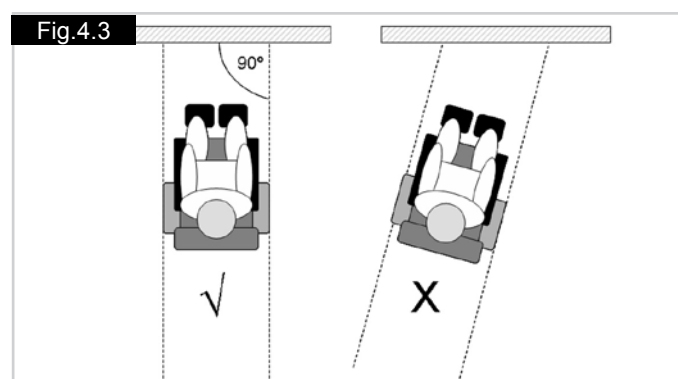

WARNING!

The approach speed and process can vary depending on your wheelchair drive type and castor wheel choice.

4.33.1 Dismounting the kerb with a rear wheel drive chair

WARNING!

Reverse the chair slowly and carefully until both rear wheels are on the edge of the kerb, again in a 90° position to the kerb.

Reverse as slowly as possible off the kerb with the rear wheels. You will feel more secure if you can lean forward, but if you can't, don't worry, the wheelchair is extremely stable. As long as you stay within its limitation, you will be quite safe.

The front of the chair will naturally follow down the kerb as you continue to drive slowly backwards.

We recommend to use the lap strap to feel more secure during declining the kerb.

4.33.2 Dismounting the kerb with a front (FWD) or mid wheel drive (MWD) chair

WARNING!

Move the chair slowly and carefully in a forward direction until both front wheels are on the edge of the kerb, again in a 90° position to the kerb. (Fig 4.3)

Drive as slowly as possible off the kerb with the drive wheels. Don't stop the chair during declining the kerb. You will feel more secure if you can lean backwards, but if you can't, don't worry, the wheelchair is extremely stable. As long as you stay within its limitation, you will be quite safe.

The rear of the chair will naturally follow down the kerb as you continue to drive slowly forwards.

All powered seating options need to be in home position. Your powered leg rests may need to be adjusted to give enough clearance to mount or dismount the kerb.

We recommend to use the lap strap to feel more secure during declining the kerb. For extra protection we recommend to fit every chair with the leg rests.

4.33.3 Kerb climber fitting and removal procedure (RWD base only)

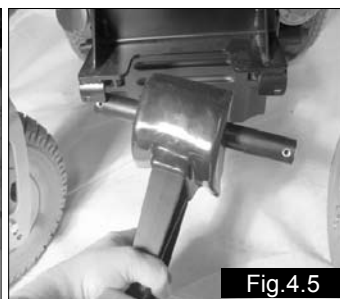
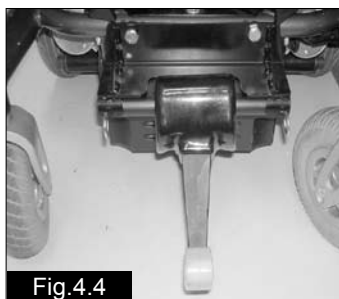

- Locate the kerb climber bar into the left hand location bracket and push it into the right hand receiver bracket (Fig. 4.4 and Fig 4.5).
- Hold the kerb climber with your right hand in the receiver bracket.
- Align the holes of the receiver bracket and the kerb climber tube and plug in the locking pin from the top.

Reverse the procedure to remove the kerb climber.

DANGER!

1. Please show the utmost consideration for the other traffic on the road. Remember that the last thing a car or lorry driver expects to see is a wheelchair backing off the kerb into the road. If in any doubt, do not risk crossing the road until you are certain that it is safe.
2. Always cross the road as quickly as possible; there may be other traffic.
3. Do not attempt to go up or down more than a 10 cm (4") high kerb (Jive R only with kerb climber fitted).
4. Do not attempt to use the kerb climber on a series of steps.
5. Do not attempt kerbs if on steep slopes or cambers.
6. Do not attempt any kerbs in the vicinity of drain covers, uneven or gritty road surfaces.
7. Do not attempt to dismount a kerb any higher than 5 cm (2") in the forwards direction in a RWD-chair.
8. Do not mount or dismount kerbs at an angle other than straight on (90 degrees) to the edge of the kerb.
9. Prior to climbing ensure your leg rests will clear the kerb.
10. Take care of the anti tips which might interfere with the kerb or the ground when mounting or dismounting a kerb.

WARNING!

This wheelchair is designed to be repaired and assembled by a Sunrise Medical authorised dealer and not the end user. The end user has to disassemble and assemble the chair only for transportation (see section 5.2).

4.34 Lap strap

The 5 cm (2") Aircraft Buckle lap strap. (Fig. 4.6).



The 5 cm (2") Aircraft Padded Lap strap. (Fig. 4.7)



The lap strap fitted for a right-handed user. (Fig. 4.8)



The lap strap fitted for a left-handed user. (Fig. 4.9)



Place the strap loosely across the seat with the opening end of the buckle facing to the right for a left-handed person and to the left for a right-handed person. (Fig. 4.10)



Pass the other ends of the strap through the gap between the backrest posts and the backrest upholstery as shown above. (Fig. 4.11)



Feed the bracket ends of the straps under the backrest brace bar as shown, using the lower fixing hole. Ensure that the adjuster buckles can be accessed and the strap is not twisted, (Fig. 4.12).



Put a washer on the bolt. Pass the bolt through the lap strap fixing bracket. Put the next washer on to the bolt, (Fig. 4.13).

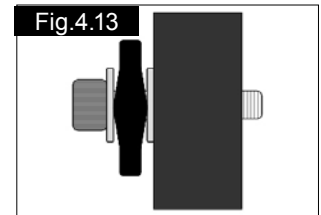

Screw the bolt into the lowest pre-drilled hole in the frame. (Fig. 4.14)



Tighten using a 5.0mm hex wrench to a torque value of 10Nm, (Fig. 4.15).



Adjust the lap strap to suit, leaving no more than a hand's width gap for comfort and safety.

The hand clearance should be with the lap strap under normal tension and not allow large gaps or loops, (Fig. 4.16).



Generally, the lap strap should be fixed so that the straps sit at an angle of approximately 45° (Fig. 4.17), and when correctly adjusted should not allow user to slip down in the seat.



DANGER!

- Always make sure that the lap strap is correctly secured and adjusted prior to use.
- Too loose a strap could cause the user to slip down and cause serious injury.
- Check lap strap and securing components at regular intervals for any signs of fray or damage. Replace if necessary
- When servicing, check for correct operation of the release buckle and for any signs of wear on the material or plastic brackets.
- Lap straps are not suitable for transit purposes, approved occupant restraint systems must be used.

NOTES:

1. Standard Sling - Lap strap movement is restricted by upholstery
2. Contoured back - Use universal bottom bracket as per recline back method

5.0 Preparing your wheelchair for use

5.1 Handling the wheelchair

NOTE: To dismantle the chair for transport or storage no tools are required.

The list of components when dismantled: (components below are related to the maximum detachable parts and dependent on the type of seating system chosen):

- 1 pair of armrests
- 1 pair of leg rests, or single centre mount leg rest with flip-up footplate
- 1 backrest (Jay/ Jay Comfort)
- 1 drive unit with seat frame.

5.2 Preparation for transportation or storage

First remove the leg rests if swing away leg rests are attached. In the case of a centre mount leg rest, just flip up the footboard. Lift off the armrests (Fig. 5.1), disconnect the hand control if necessary, (Fig.5.3-5.4). Release the retainer pin and fold down the backrest at the frame (Fig. 5.2). Now you can store the chassis part. By releasing the freewheel mechanism (Fig. 5.5 RWD-FWD and Fig. 5.6 MWD) on the left and right side of the chassis you can move the drive unit as close as possible to the place you want to store it.

You can also drive the base with the joystick up or down a ramp into and out of a car for transportation.

 **WARNING!**

Make sure, when the chair is stored or left in the car or anywhere else, the controller is switched off and the freewheel mechanisms are engaged.

 **CAUTION!**

If there is a need to lift the drive unit on the RWD and FWD chair the big side frame tubes should be used. On the MWD use the rear castor arm and the drive wheel. Caution should be taken if the chair is in freewheel.

To remove the control pod:

VR2: Loosen the adjustment screw on the control arm and slide the arm out of the bracket, (Fig 5.3). Place the controller and arm in a safe place until required.

R-net: Locate the in-line bus connector. Gently pull the plugs apart to separate the loom, (Fig. 5.4). To reconnect the hand control just repeat the process in reverse.

5.3 Re-Assembling

Flip up or replace the backrest. Put your armrests back in and connect the remote controller. Attach the hangers or flip down the footplate. Make sure your freewheel mechanisms are engaged. Now you are ready to drive the chair.

 **WARNING!**

Never lift the wheelchair by the armrests or the leg rests, since they are detachable and harm could be done to the user or to the wheelchair.

5.4 Emergency freewheel

Jive F/R

By pressing the freewheel levers on both sides of the base into the down position (Fig. 5.5), the drives become disconnected from the motors.

Jive M

By pulling the freewheel levers outwards from both sides of the base (Fig. 5.6), the drives become disconnected from the motors.

 **DANGER!**

This may only be used in an emergency, or if you need to manually push your wheelchair. It is not intended for permanent use or to push the wheelchair up/down a slope with the user sitting in it.

NOTE: The chair's automatic braking system will not work unless the brake release levers are in the "drive" position.

 **WARNING!**

Motor surfaces can be hot after use. Be careful not to touch the motor casing when disengaging the freewheel.

 **WARNING!**

Never attempt to disengage the freewheel mechanism whilst sitting in the wheelchair, especially on a slope.

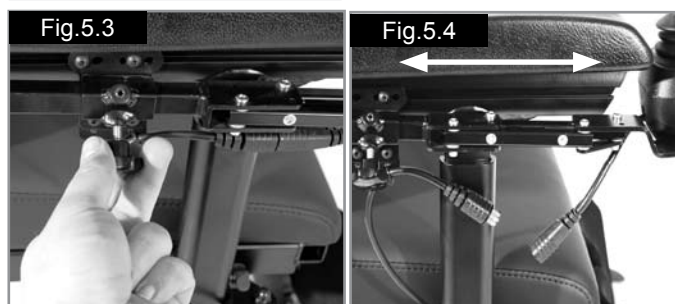
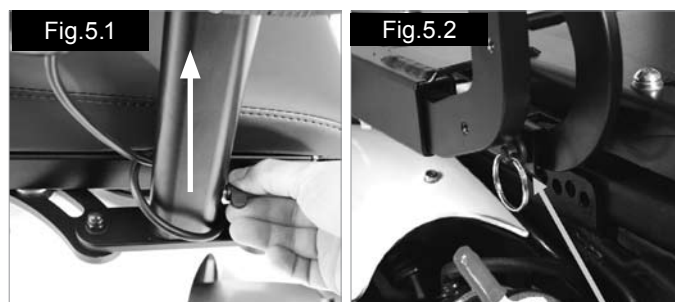

5.5 Drive wheel suspension Jive F/R

The Jive F/R has an effective and adjustable drive wheel suspension system as a standard feature. To match your requirements on drive comfort, the tension of the springs at the damper can be adjusted.

Turning the aluminium ring on the bottom of the spring downwards will soften your ride, adjusting the aluminium ring in a higher position will harden it. This option is to be used to match the different user weights to the suspension system. (Fig. 5.7). We recommend the suspension adjustments are done equally on the left and right side of the chair.

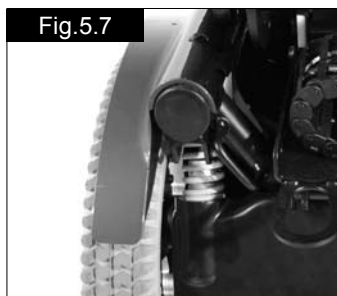

5.6 Control joystick unit position

Depending on your chosen control system, there are two principles of control systems: Quickie VR2 and Quickie R-net controls (for details please see the controls section 7). The remote is mounted on a sliding mechanism which enables the control to be moved forwards and backwards.

- Undo the locking screw, (Fig.5.3).
- Slide the control arm either out or to its new position, (Fig.5.4).

When the most comfortable position has been selected, secure the slider by tightening the locking screw. Ensure the locking screw is fully tightened prior to use and especially when transporting your wheelchair.

5.7 Arm Rests

5.7.1 Arm Rests-removing

The arm rests on both sides of the wheelchair can be removed to allow side transfer.

Please refer to your appropriate arm rest type.

For single post arm rests:

- Undo the finger wheel at the bottom of the post, (Fig.5.1).
- Lift the arm rest out of the receiver, (Fig.5.1).

Reclining arm rest:

- Undo the star wheel at the bottom pivot of the arm rest.
- Lift the arm rest up out the receiver. You can now flip it backwards, (Fig. 5.8).



For F-XL and Recaro:

Single Post Armrest:

Release the handle screw on the side of the armrest receiver and remove armrest (Fig. 5.8.1).

5.7.2 Arm Rests-replacement

Please refer to your appropriate armrest type.

Single Post Armrest Jay- Jay Comfort:

- Place the armrest tube in the armrest receiver.
- Fix and tighten the finger wheel, (Fig. 5.4).

Reclining armrest:

Move the arm rest from the flip back position and place the post into the receiver.

Tighten the star wheel on the receiver to lock the post into position, (Fig. 5.8).

5.7.3 Adjusting the armrest width (Jay and Jay Comfort Seat only)

To adjust the width:

- Loosen the four screws (13mm spanner) as shown in (Fig. 5.9).
- Move the armrest receiver brackets to the desired position, (Fig. 5.10).
- Tighten the screws firmly prior to use.

NOTE: Please check that the new arm rest position does not interfere with any seat positioning modules, Lift-Tilt etc.



5.7.4 Adjusting armrest height

Please refer to your appropriate armrest type.

Single Post Arm Rest (Comfort, Rehab and Recaro Seat):

The height adjustment of the armrests is made via the threaded screws at the forward edge of the stanchion tube. To adjust the height, (Fig. 5.11) loosen the adjusting screws (3.0 mm Allen Key), move the armrest to the desired position and tighten the screw.

Reclining arm rest, (Fig.5.12):

- Loosen the screw at the rear armrest receiver.
- Slide the armrest extrusion up or down inside the slot in the backrest frame.
- Tighten the screw at the appropriate height.
- Loosen the set screw on the front post.
- Adjust the front height.
- Tighten all screws.
- Repeat for the other side.

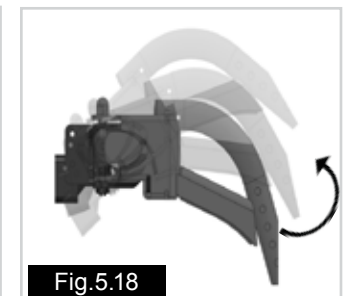
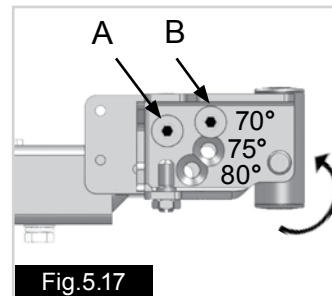
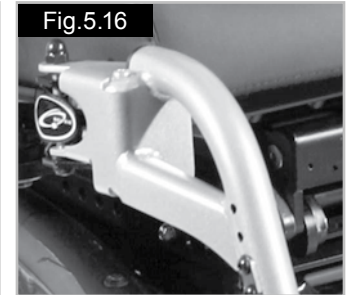
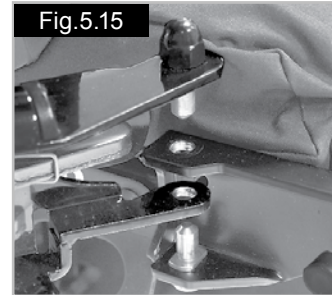
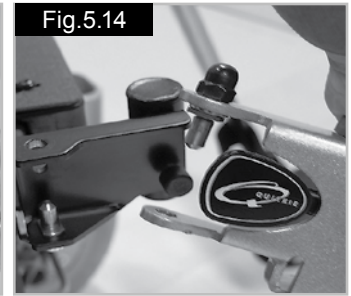
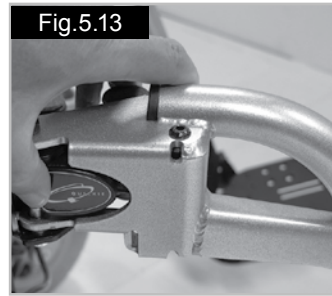

5.8 Leg Rests



- Be aware of your environment to make sure you do not injure your legs when Leg Rests are extended.
- Always ensure that the Leg Rests or foot plates do not come into contact with the castors before driving the wheelchair.
- Leg Rests are not to be used for lifting or carrying the wheelchair under any circumstances.
- As with all moving parts be careful not to trap your fingers.

5.8.1 Leg rest removal

To swing away the leg rest:

- Depress the retaining catch and swing the leg rest out, (Fig.5.13).
- Lift the leg rest up and off if removal is required, (Fig.5.14).

To refit:

- Line up the holes and studs, (Fig.5.15).
- Drop the leg rest into the receiver.
- Push the leg rest inwards until it clicks shut, (Fig.5.16).

To adjust the angle: (Fig 5.17-5.18).

- Use a 5.0mm Allen key and 13.0mm spanner to loosen stud A,
- Remove stud B.
- Tilt the receiver until the required hole lines up with the top hole.
- Refit the stud.

5.8.2 Foot plates

The foot plates may be flipped up to aid entry and exit from the chair.



Do not use the foot plates to stand on as the full weight of your body may cause the chair to tip forwards. This could result in injury and could damage the foot rests.

5.8.3 Adjusting the foot rest length

To adjust the foot rest length remove the bolts/screws on the foot rest stem as shown in (Fig. 5.19, 70° and 5.20, Centre Mount), adjust the length to suit. Ensure the bolts/screws are firmly located and tightened prior to use.

NOTE: The internal foot rest stem may require cutting down in length to allow the foot plate position to be raised.

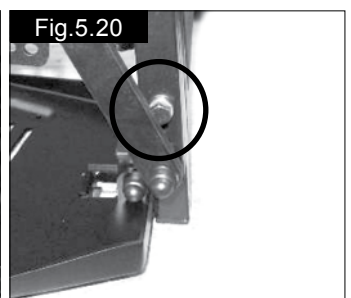
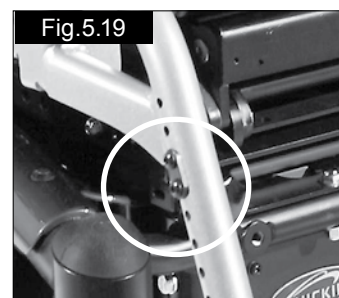

5.8.4 Manual, elevating leg rest, (ELR, Fig.5.21).

To elevate:

Pull the leg rest upwards and stop at the desired height. The leg rest will automatically lock in the chosen position.

To lower:

Push the release lever slowly forward. The leg rest will lower the angle. As soon as you release the lever, the leg rest will be locked in the current position, (Fig.5.21).



WARNING!

Keep hands clear of the adjustment mechanism between the frame and the movable parts of the leg rest while elevating or lowering the leg rest.

NOTE: Please refer to Section 7 for details of your controls

5.8.5 Powered elevating leg rest, (ELR, Fig.5.22) or articulating leg rest, (ALR, Fig.5.23).

NOTE: Both left and right leg rests can also be operated simultaneously.

To operate a powered ELR, or ALR leg rest:

VR2 Control:

The actuator buttons can operate any factory approved actuator. Operation is dependent on what options are fitted to your wheelchair, (Fig.5.24).

To operate the leg rests, seat tilt, seat lift or backrest recline:

- Push one of the actuator buttons that has the seat icon on it to select actuator mode.
- Operate the joystick left or right to select the actuator required (actuator 1 or actuator 2). Selection is indicated via the lighting of the red LED adjacent to the desired actuator button.
- Operate the joystick in the forward or rearward direction to move the leg rest/seat lift/tilt or recline up or down.
- Release the joystick when the desired angle is reached.
- To return to drive mode press the actuator button again.



CAUTION!

Once the leg rest is fully lifted or in its lowest position do not hold the joystick in its operating position as this could damage the actuator..



R-net Control

Please refer to your R-net Owner's Manual for details.



5.8.6 Powered centre mount leg rest, (PCML).

WARNING!

There is an option on the programme of the leg rest that allows you to send the footrest to the floor to allow for easier mounting and dismounting for the user. Be aware that when powered the area around and underneath the footplate needs to be clear of all personal items and bodily extremities to prevent injury or damage to property.

CAUTION!

Once the leg rest is fully lifted or in its lowest position do not hold the joystick in its operating position as this could damage the actuator.

To operate the PCML (Fig 5.25):



To operate the leg rest using VR2 Control, (Fig.5.24):

- Push one of the actuator buttons that has the seat icon on it to select actuator mode.
- Operate the joystick left or right to select the actuator required (actuator 1 or actuator 2). Selection is indicated via the lighting of the red LED adjacent to the desired actuator button.
- Operate the joystick in the forward or rearward direction to move the leg rest/seat lift/tilt or recline up or down.
- Release the joystick when the desired angle is reached.
- To return to drive mode press the actuator button again.



R-net Control

Please refer to your R-net Owner's Manual for details.

6.0 Seating

6.1 Seat cushions

Seat cushions supplied by Sunrise Medical will have Velcro® strips that correspond to patches on the seat.

WARNING!

- You must ensure the strips are aligned prior to using the wheelchair.
- Other cushions used should also have Velcro® strips in a similar position to ensure the cushion does not slip off the seat.

NOTE: The seat cushions, supplied by Sunrise Medical all have removable covers.

6.2 Changing seat depth on the standard rehab seat

- Loosen the arm rest width adjustment screws, using a 13.0mm spanner, (2 and 3, Fig 6.1).
- Loosen the Mechanical Fixed Recline/ Gas Strut / electric Actuator fixing screws, (1 and 2, Fig 6.2).
- Repeat for the other side.
- Slide the inner seat frame to the desired position.
- Tighten all screws, (Fig.6.1-6.2).

WARNING!

- Sunrise Medical strongly recommend that you contact your approved Sunrise medical servicing agent to carry out this task.

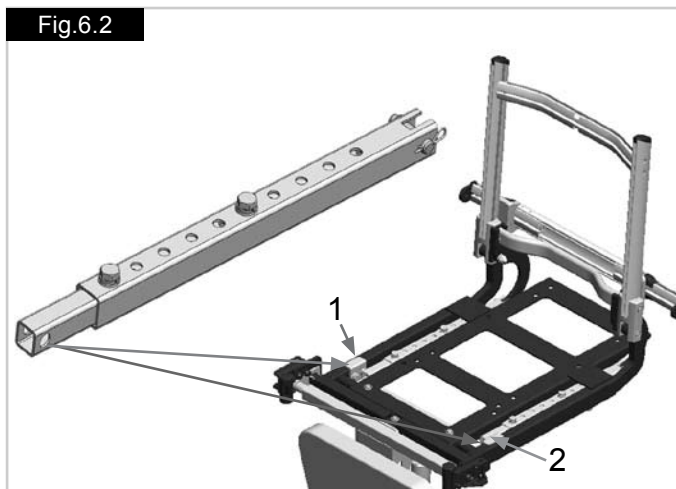
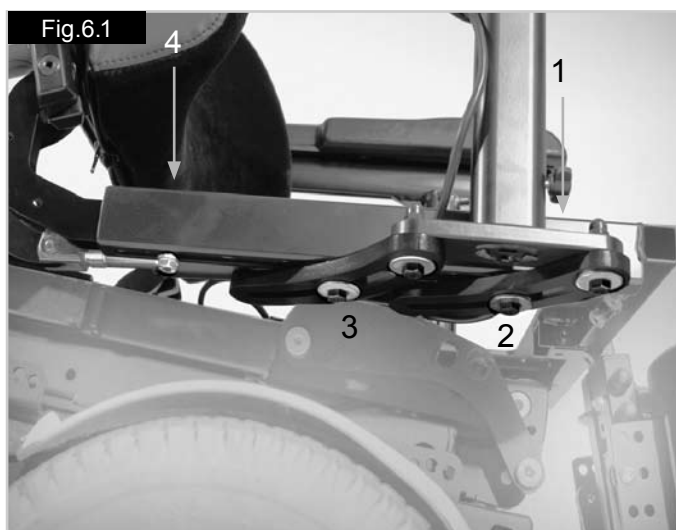

6.3 Changing seat height

There are four adjustable seat posts, one at each corner of the drive base, (Fig. 6.3, 6.4 and 6.5 FWR/RWD, Fig.6.6 MWD).

The posts are held in place by bolts inserted through adjustment holes.

To adjust the seat height:

- Remove the bolts from the posts using two 13 mm spanners.
- Move the posts to the desired position.
- Replace the bolts into the new holes in the posts.
- Tighten the bolts.



- Sunrise Medical strongly recommend that you contact your approved Sunrise medical servicing agent to carry out this task.
- If any bolts are removed from the seat frame or seat posts it is possible that unexpected movement of the assembly may occur. This could result in serious injury.

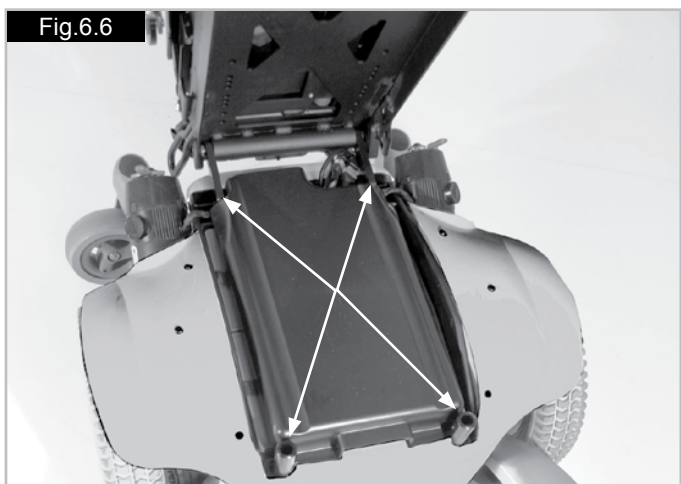
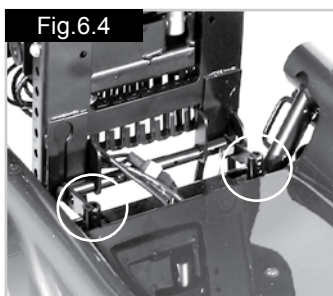

6.4 Removable seat covers

The seat covers are all fully removable using zips or Velcro®. Once brackets are removed seat covers can be removed. The zip for the backrest is located on the underside of the cushion.

6.5 Backrest, folding for transport

Although there are a variety of back upholsteries which can be used on the Jive backrest structure, they all fold down in the same way.

To fold the backrest, (Fig. 6.7):

- Release the retainer pins on both sides.
- Fold down the backrest at the junction with the seat frame.
- Reverse the procedure to reinstate the backrest.



- You must ensure the two retainer pins are securely locked in position and the backrest is correctly and firmly in place prior to using your chair.
- If a Powered or Gas recline back rest is fitted, be sure to bring the back rest to the fully forward position. This allows the complete extension of the actuators so that no further unexpected movement can occur.

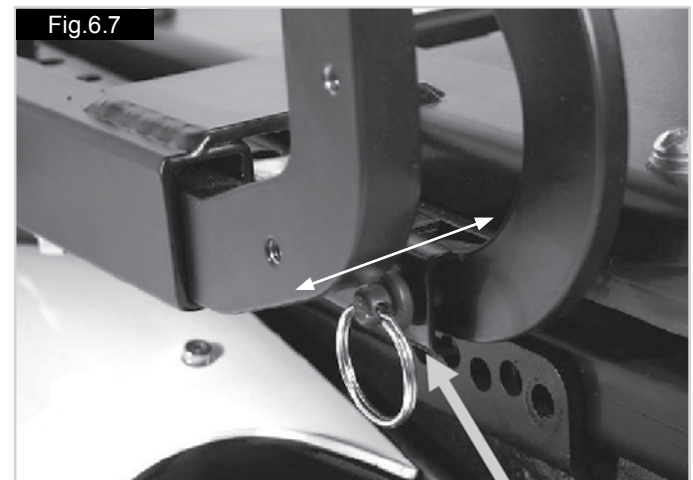

6.6 Manual angle adjustment of the fixed back

To adjust the back angle:

- Use a 13.0mm spanner.
- Remove the two screws on the mechanical fixed recline adjusters, (Fig.6.2).
- After removing the screws you can set the back angle between -3°(degrees) and 12°.
- Tighten all screws.



You must ensure all 4 screws are securely tightened and the backrest is correctly and firmly in position prior to using your chair.

6.7 Manual adjustable backrest (manual recline)

For depth adjustment see section 6.2.

To recline the backrest angle, pull the lever at the top of the backrest which operates the gas strut. Hold the lever and adjust the back angle required. If you release the lever, the angle will stay in the adjusted position. If you want to adjust the backrest into the upright position, you might need to support the upward motion (Fig. 6.8).



6.8 JAY backrests

The standard backrest assembly will allow the fitting of a JAY backrest, which is available as an optional extra.

6.9 Headrest

To fit the headrest, fit the location bracket to the backrest bracket, using the screws and nuts supplied, ensuring that they are fully tightened.

The headrest height is changed by loosening the adjustment lever on the stem, slide the inner vertical tube to the desired position and tightening the lever. The headrest to seat depth is adjusted by loosening the 6mm Allen screws and moving the hinge to the desired position and then tightening the screws securely. To adjust the headrest angle, loosen the screws at the headrest upholstery, position the headrest as required and tighten the screws securely.

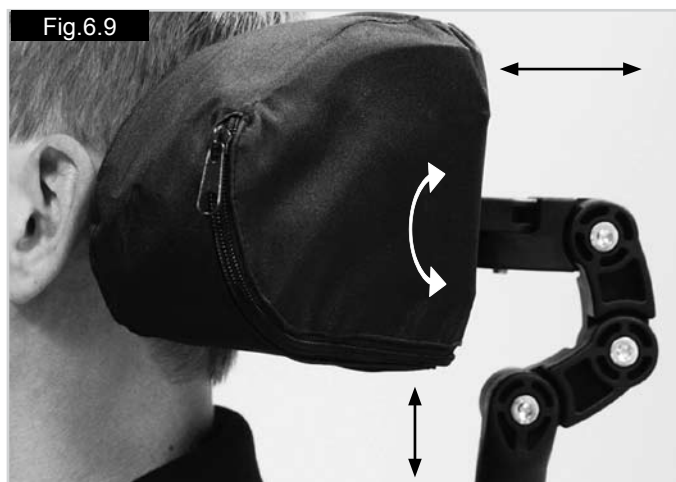

6.10 Manual setting of the seat angle on the Jive

To set the seat angle, release the bolt fixing the “Banana” bracket between the seat interface module and the seat packer module. Set the seat angle at 0°, 3° or 6° and 9°, then replace and retighten the bolt between the seat interface module and the seat packer module. (Fig. 6.10).

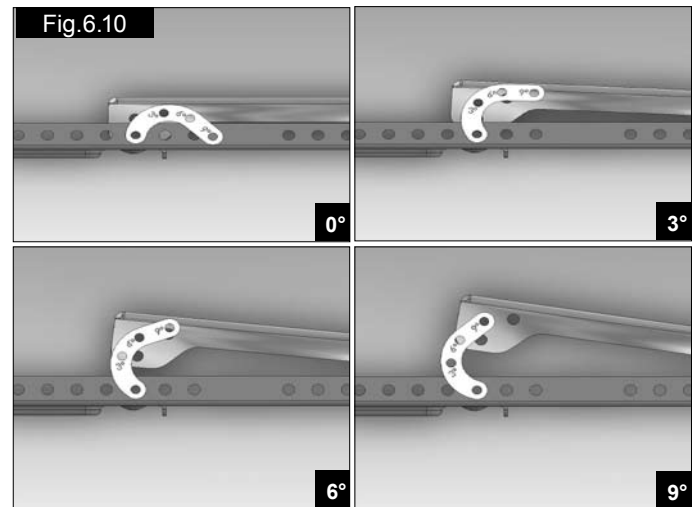

6.11 Powered Seating

⚠ WARNING!

- The Jive F-XL cannot be fitted with powered options.
- It is possible to reverse the direction of an actuator relative to the direction of the joystick. Ensure you know which direction to move the joystick for the desired operation. Failure to do so may result in damage and/or injury.
- Powered seat functions can be operated in “latched” mode. To stop a latched seat function before the end of travel, operate the joystick in the reverse direction.

NOTE: Please refer to **Section 7** for details of your hand controls.

6.11.1 Powered adjustable backrest

The backrest can be reclined by operating your control system as follows:

VR2 Control:

To recline the backrest angle:

- Push one of the actuator buttons that has the seat icon on it to select actuator mode.
- Operate the joystick left or right to select the actuator required (actuator 1 or actuator 2). Selection is indicated via the lighting of the red LED adjacent to the desired actuator button.
- Operate the joystick in the forward or rearward direction to move the recline up or down.
- Release the joystick when the desired angle is reached.
- To return to drive mode press the actuator button again.

 **CAUTION!**

Once the back is fully reclined or raised do not hold the joystick in its operating position as this could damage the actuator.



R-net Control

Please refer to your R-net Owner's Manual for details.

 **WARNING!**

- Lowering the backrest by an angle of greater than 15° from vertical alters the balance of your wheelchair.
- Never exceed 15° of recline when on any gradient or when driving your wheelchair.
- If it is clinically safe to do so, bring the back rest back to the upright position when travelling along.

6.11.2 Powered seat lift

The seat can lift up to 30 cm by operating it through your control system.

 **WARNING!**

- Before operating the seat lift function ensure that the immediate area around the wheelchair is clear of possible obstructions,
- (eg wall shelving), and potential hazards, (eg small children and pets).
- Operating the seat lift will limit the drive speed of the wheelchair.
- Operating the seat lift and another electric option will stop the drive all together.

VR2 Control:

To operate the powered lift:

- Push one of the actuator buttons that has the seat icon on it to select actuator mode.
- Operate the joystick left or right to select the actuator required (actuator 1 or actuator 2). Selection is indicated via the lighting of the red LED adjacent to the desired actuator button.
- Operate the joystick in the forward or rearward direction to move the seat lift up or down.
- Release the joystick when the desired height is reached.
- To return to drive mode press the actuator button again.

 **CAUTION!**

Once the seat is fully raised or fully down, do not hold the joystick in its operating position as this could damage the actuator



R-net Control

Please refer to your R-net Owner's Manual for details.

6.11.3 Powered seat tilt

The seat can be tilted by operating your control system.

VR2 Control:

To operate the powered tilt please follow the instructions listed in section 6.11.2, but select the actuator button associated with the Tilt function.

 **WARNING!** 

- Before operating the seat Tilt function ensure that the immediate area around the wheelchair is clear of possible obstructions, (Fig. 6.11).
- (eg wall shelving), and potential hazards, (eg small children and pets).
- Operating the seat Tilt will limit the drive speed of the wheelchair.
- Operating the seat Tilt and another electric option will stop the drive all together.



R-net Control

Please refer to your R-net Owner's Manual for details.

NOTE: With the seat lift raised the maximum speed is limited to approximately 10% of its normal value. This is known as "Creep Mode".

Raising the seat in combination with other powered seating options, such as tilt/recline/leg rests, can suspend the normal drive options, (depending on programming). This is quite normal and is a safety feature.

To start driving the wheelchair again, bring the seating options back to their start positions.

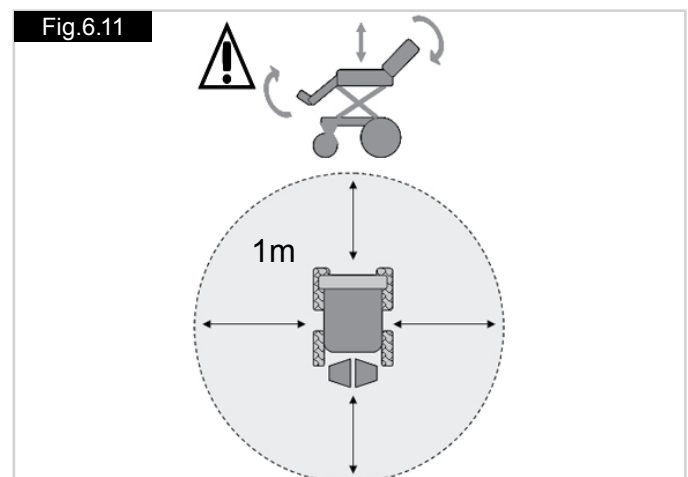

7.0 VR2 Control System (Fig.7.1):

Your wheelchair is controlled by the Joystick. This regulates the power & speed of the wheelchair. The Joystick determines the speed and direction of the wheelchair.

7.1 On/Off button:

The On/Off button applies power to the control system electronics, which in turn supply power to the wheelchair's motors.

WARNING!

Do not use the on/off button to stop the wheelchair unless there is an emergency. (If you do you may shorten the life of the wheelchair drive components).

7.2 Battery Level Indicator:

The battery gauge shows you that the wheelchair is switched on. It also indicates the status of the wheelchair. Refer to Fig.7.1.

7.3 Locking/unlocking the wheelchair:

The VR2 control system can be locked to prevent unauthorised use. The locking method is via a sequence of key presses and joystick movements as detailed below.

To lock the wheelchair;

- While the control system is switched on, depress and hold the On/Off button.
- After 1 second the control system will beep. Now release the On/Off button.
- Deflect the joystick forwards until the control system beeps.
- Deflect the joystick in reverse until the control system beeps.
- Release the joystick, there will be a long beep.
- The wheelchair is now locked.

To unlock the wheelchair;

- Use the On/Off button to switch the control system on. The maximum speed/profile indicator will be rippling up and down.
- Deflect the joystick forwards until the control system beeps.
- Deflect the joystick in reverse until the control system beeps.
- Release the joystick, there will be a long beep.
- The wheelchair is now unlocked.

WARNING!

To avoid unexpected or unintentional movement of the wheelchair and to conserve battery power, it is recommended that the control system is switched Off when drive or seating adjustments are not being used.

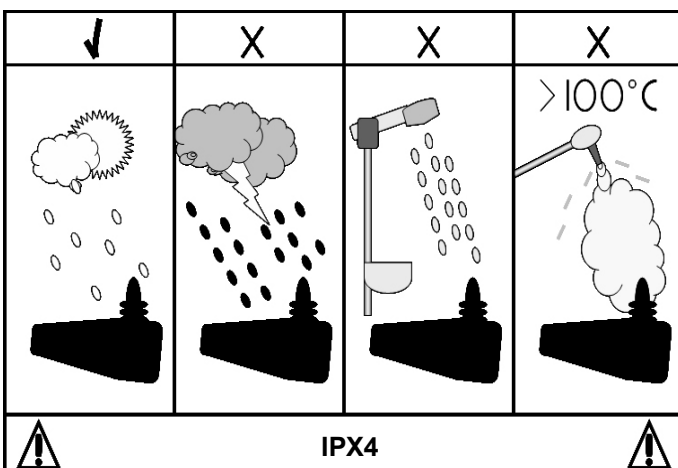

Fig.7.1

7.4 Operating the control joystick:

When engaging the main On/Off button, allow a few seconds prior to moving the joystick. This allows the system to self check. If you move the joystick too soon, the battery level indicator display will not illuminate until the joystick is released.

If the joystick is off centre at the time of switching on, after 5 seconds a system error will occur.

Whilst this is not harmful to your wheelchair, you will need to switch off and then back on to clear the system.

Note: This is a safety feature to prevent unintended movement.

Proportional control summary:

Steering.

To steer the chair simply move the joystick knob in the desired direction. The further you move the joystick from the central position, the faster the wheelchair will travel in the direction the joystick is pushed.

Look ahead while you drive, not at the controls.

Stopping.

When the joystick returns to its central position, the brakes will activate automatically.

Braking Distance.

On flat ground, braking distance is approximately equal to the length of the wheelchair. Going downhill the braking distance may be slightly longer.

Forward/Reverse.



WARNING!

It is important that you stop the wheelchair before you change direction from forward to reverse.



WARNING!

Always turn the controller off before you transfer in or out of the wheelchair.

7.5 Maximum speed/profile indicator:

This is a gauge which shows the maximum speed setting for the wheelchair or if the control system is programmed for drive profile operation, the selected drive profile. This gauge also indicates if the speed of the wheelchair is being limited or if the control system is locked.

7.6 The horn button:

The horn will sound while this button is depressed.

7.7 Speed/Profile decrease button:

This button decreases the maximum speed setting or, if the control system is programmed for drive profile operation, selects a lower drive profile.

7.8 Speed/Profile increase button:

This button increases the maximum speed setting or, if the control system is programmed for drive profile operation, selects a higher drive profile.

Remember that only with practice will you become a competent driver. Find a safe, hazard free environment to practice controlling the wheelchair and familiarise yourself with the controls and functions.

7.9 Actuator button and LEDs:

Depending on whether your wheelchair is fitted with one or two actuators the operation of this button will differ.

Wheelchairs with one actuator:

Depressing the actuator button will enter actuator adjustment mode. This will be indicated by the illumination of both actuator LED's. Actuator adjustment can then be made by deflecting the joystick forwards or backwards. To re-enter drive mode, depress either actuator button.

Wheelchairs with two actuators:

Depressing the actuator button will enter actuator adjustment mode. Depressing the button once illuminates the left LED, and deflection of the joystick will adjust the actuator motor connected to that channel. If the right button is depressed the associated LED will be illuminated, and deflection of the joystick will adjust the actuator motor connected to the other channel.

To re-enter drive mode, depress the selected actuator button, as indicated by the associated LED.

It is also possible to select the other actuator by left or right movements of the joystick.

7.10 VR2-L

There are common controls between the VR2 and the VR2-L control systems where a control differs it will be described below. All common controls can be found on the previous page.

Lights and indicators:

The wheelchair can be equipped with lights and indicators. Where lights are not factory fitted, they may be fitted as an optional extra by an approved Sunrise Medical authorised dealer.

WARNING!

Ensure that the lights and indicators are functioning correctly and lenses are clean before going outdoors at night.

Indicators:

To turn on the wheelchairs indicators operate the required button either left or right, the associated LED will also illuminate continuously.

If the LED flashes rapidly either a total short circuit, a single lamp open circuit or a total open circuit in the left or right indicator circuit has been detected.

Depress the indicator button to turn off the indicator and the associated LED.

Main lights:

To turn on the wheelchairs lights operate this button, the associated LED will illuminate continuously.

If the LED flashes a short circuit in the lighting circuit has been detected.

Depress the light button to turn off the lights and the associated LED.

Hazard warning lights:

To turn on the wheelchairs hazard warning lights operate this button, the associated LED will flash at the same rate. The left and right turn indicator LEDs will also flash.

If the LED flashes rapidly either a total short circuit, a single lamp open circuit or a total open circuit in the entire indicator circuit has been detected.

Depress the hazard warning button to turn off the lights and the associated LED.

Actuator button and LEDs:

Depending on whether your wheelchair is fitted with one or two actuators the operation of this button will differ.

Wheelchairs with one actuator

Depressing the actuator button will enter actuator adjustment mode. This will be indicated by the illumination of both actuator LED's. Actuator adjustment can then be made by deflecting the joystick forwards or backwards. To re-enter drive mode, depress either actuator button.

Wheelchairs with two actuators

Depressing the actuator button will enter actuator adjustment mode. Depressing the button once illuminates the left LED, and deflection of the joystick will adjust the actuator motor connected to that channel. If the right button is depressed the associated LED will be illuminated, and deflection of the joystick will adjust the actuator motor connected to the other channel.

To re-enter drive mode, depress the selected actuator button, as indicated by the associated LED.

It is also possible to select the other actuator by left or right movements of the joystick.



Fig. 7.2

7.11 Charging and programming socket: (Fig.12.8-12.10)

WARNING!

This socket should only be used for programming and charging the wheelchair.

This socket should not be used as a power supply for any other device.

Connection of other electrical devices may damage the control system or affect the EMC performance of the wheelchair.

See Section 12.0 about charging.

The programming socket will enable an approved Sunrise Medical authorised dealer to re-programme your chair and also gain useful information when tracing any faults. When the chair leaves the factory, the parameters of the controller are set to default.

To programme the controller you need a special programming device (handheld or PC software), which is available to your Sunrise Medical authorised dealer.

WARNING!

Programming the controller of the wheelchair is only allowed through authorised personnel trained by Sunrise Medical. Incorrect controller settings could cause driving outside the safe limits and could result in damage or injury.

NOTE: Sunrise Medical does not accept responsibility for damages which result from unexpected movement or stopping of the wheelchair due to inappropriate programming or unauthorised use of the wheelchair.

7.12 VR2 dual control unit:

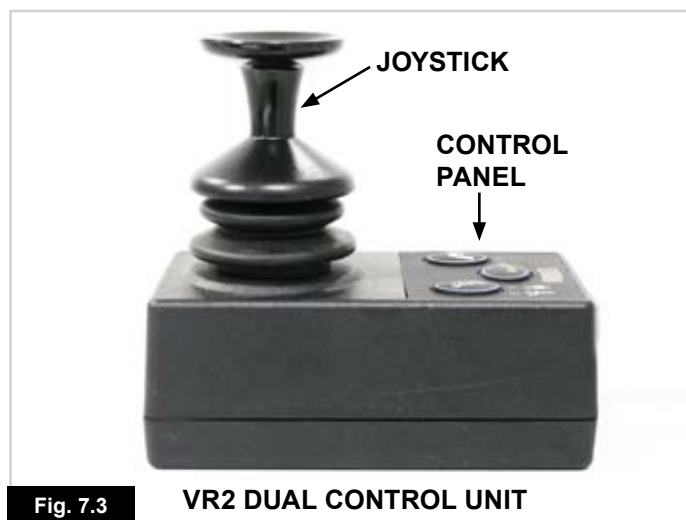

7.13 Control button and indicator:

This shows which joystick has control. If the red wheelchair light is on the wheelchair occupants joystick has control. If the green attendant light is on the dual attendant systems joystick has control. The button is used to transfer control between the two choices, (Fig.7.4).

7.14 Actuator button and LED:

All VR2 dual attendant systems have an actuator button fitted as standard. If the VR2 is programmed with no actuators then this button has no function, (Fig.7.4).

Wheelchairs with one actuator:

Depressing the actuator button once will enter actuator adjustment mode. This will be indicated by the illumination of both actuator LED's. Actuator adjustment can then be made by deflecting the joystick forwards and backwards.

To re-enter drive mode, depress either the actuator button or the speed button.

Wheelchairs with two actuators:

Depressing the actuator button will enter actuator adjustment mode. Depressing the button once illuminates the left LED and deflection of the joystick forwards or backwards will adjust the actuator connected to that channel. Selection between the two actuators is achieved by deflecting the joystick to the left and right. As the actuator selected changes so will the LED which illuminates. Left for actuator 1 and right for actuator 2.

To re enter drive mode, depress either the actuator button or the speed button.



7.15 Maximum speed button and indicator:

This shows the maximum speed setting for the wheelchair when the dual attendant system has control. There are five settings - setting 1 is the slowest speed and setting 5 is the highest speed. The speed setting is changed with the speed button, (Fig.7.4).

If the control system is programmed for drive profile operation, then the dual attendant system speed adjuster will only adjust the speed within the selected profile. Changing between drive profiles can only be achieved using the VR2 main joystick.

WARNING!

To avoid unexpected or unintentional movement of the wheelchair and to conserve battery power, it is recommended that the control system is switched Off when drive or seating adjustments are not being used.

Note: Always move the chair with care.

If the programming of the attendant drive profile (s) needs adjustments to make it more convenient for the attendant and/or the person sitting in the wheelchair, please contact your Sunrise Service agent for adaptation. If the direction of movement of the directional attendant control needs to be altered, please contact your authorised Sunrise Medical dealer for adaptation.

WARNING!

Do not attempt to program the wheelchair yourself. Always consult a qualified health care professional. Contact your Sunrise medical approved dealer for details.

7.16 Quickie Direct Actuator Control Box:

The direct actuator switches can operate any factory approved actuator. Operation is dependent on what options are fitted to your wheelchair. To operate the leg rest, seat tilt or backrest recline; Push the toggle switch for the relevant actuator forward until you reach the required angle/height. Release the toggle switch and the actuator will stop. When the actuator reaches its maximum/minimum position do not hold the toggle switch in its operating position as this could damage the actuator. (Fig. 7.5).



8.0 Troubleshooting The VR2 Hand Control:

Always consult your Sunrise Medical authorised dealer when a diagnostic fault has appeared on your hand control.

The battery gauge and maximum speed/profile indicator show the status of the control system, (Section 7.0, Fig.7.1).

Battery Gauge is steady - This indicates that everything is OK.

Battery Gauge flashes slowly - The control system is functioning correctly but the batteries need charging as soon as possible.

Battery Gauge steps up - The wheelchair batteries are being charged. You will not be able to drive the wheelchair until the charger is disconnected and you have switched the control system off and on again.

Battery Gauge flashes rapidly (even with the joystick released)
The control system safety circuits have operated and the control system has been prevented the wheelchair from moving.

This indicates a system trip. i.e. the VR2 has detected a problem somewhere in the wheelchairs electrical system.

Switch off the control system.
Make sure that all connectors on the wheelchair and the control system are mated securely.
Check the condition of the battery.
If you can't find the problem, try the self help guide on the next page.
Switch on the control system again and try to drive the wheelchair.
If the safety circuits operate again, switch off and do not try to use the wheelchair.
Contact your Sunrise Medical authorised dealer.



Please refer to the R-net Owner's Manual for details of R-net hand control functions

Self help guide, (Fig.8.1).

If a system trip occurs you can find out what has happened by counting the number of LED's on the battery gauge that are flashing.









Go to the number on the list which matches the number of flashing bars and follow the instructions.

Slow or sluggish movement - If the wheelchair does not travel at full speed or does not respond quickly enough and the battery condition is good, check the maximum speed setting. If adjusting the speed setting does not remedy the problem then there may be a non hazardous fault. Consult your Sunrise Medical authorised dealer.

Speed/Profile Indicator ripples up and down - This indicates the control system is locked, refer to section 7.3 for details on how to unlock the control system.

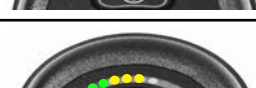
Speed/Profile Indicator flashes - This indicates that the speed of the wheelchair is being limited for safety reasons. The exact cause will depend on the build of the chair but usually indicates that the seat is elevated.

Actuator LED flashes - This indicates that the actuators may be inhibited in one or both directions.

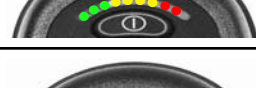
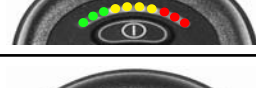
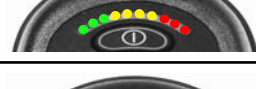
FAULT CODE	FLASH	POSSIBLE CAUSE
	1	The batteries need charging, or there is a bad connection to the battery. Check the connections to the battery. If the connections are good, try charging the batteries.
	2	The left hand motor has a bad connection. Check the connections to the left hand motor.
	3	The left hand motor has a short circuit to a battery connection. Contact your Sunrise Medical authorised dealer.
	4	The right hand motor has a bad connection. Check the connections to the right hand motor.
	5	The right hand motor has a short circuit to a battery connection. Contact your Sunrise Medical authorised dealer.
	6	The wheelchair is being prevented from driving by an external signal. One possibility is that the battery charger is plugged in.
	7	A joystick fault is indicated. Make sure that the joystick is in the centre position before switching on the control system.
	8	A control system fault is indicated. Make sure the control system connections are secure.
	9	The parking brakes have a bad connection. Check the parking brake and the motor connections. Make sure that the control system connections are secure.
	10	An excessive voltage has been applied to the control system. This is usually caused by a poor battery connection. Check the battery connections
	10 + S	S = Speed indicator LED's A communication fault is indicated. Make sure that the joystick cable is securely connected and not damaged.
	10 + A	A = Actuator LED's An actuator trip is indicated. If more than one actuator is fitted, check which actuator is not working. Check the actuator wiring.

9.0 R-net Control System

9.1 R-net control system information

An alternative control system called R-net is available for the wheelchair.

The R-net system has extended options and is suitable for individuals with complex needs or when there is a preference for screen based menu options and information displays.

The R-net control system offers simple, effective solutions to many situations, thereby enhancing the lifestyle and independence of the user.

The operation of the R-net wheelchair control system is simple and easy to understand. Both the R-net and VR2 control systems incorporate state-of-the-art electronics, the result of many years of research, to provide you with ease of use and a very high level of safety.

Because of the comprehensive nature of the R-net control system, a separate R-net Owner's Manual is supplied whenever this system is fitted.



Please refer to the R-net Owner's Manual for details of R-net hand control functions.

10.0 Controller Mounts

10.1 General warnings



WARNING!

- Do not replace the joystick knob with any unauthorised item. It may cause hazardous operation and loss of control of the chair.
- It is important that the joystick boot is replaced if it is torn or brittle; failure to do so could cause substance damage to the controller and unexpected movement of the chair.
- Ensure that you always have comfortable access to the controls whilst the chair is moving and make sure that the controller is fixed securely to the chair.



WARNING!

- To avoid unexpected or unintentional movement of the wheelchair and to conserve battery power, it is recommended that the control system is switched Off when drive or seating adjustments are not being used.

10.2 Parallel swing-away general warnings, (Fig.10.1)



WARNING!

- Before adjusting the swing-away arm, switch off the controller to avoid accidental displacement of the joystick which would cause unwanted movement of your wheelchair.
- Be aware that the width of your chair has increased if the swing-away arm is out and you may not get between certain obstacles.
- Do not hang any items on or over the parallel swing-away remote assembly as this could damage the swing-away mechanism.
- When transferring to and from the wheelchair do not use the remote as a means of support.
- Ensure the power is switched off while adjusting the parallel swing-away arm.
- Only operate the wheelchair at low manoeuvring speed when the parallel swing-away is in use. (See “parallel swing-away” picture on the right).

10.3 Attendant control, (Fig.10.2)



WARNING!

- Ensure that you set the speed of the attendant control to a speed that you can comfortably follow.
- Always turn off the power to the controller when leaving the user in the chair.

Fig. 10.1



Fig. 10.2



10.4 Centre bar mount control (R-net)

WARNING!

- Make sure that the controller is fixed securely to the centre bar.
- Always turn off the power to the controller before moving the controller out of the way.

10.5 Tray mount control (R-net)

WARNING!

- The maximum weight allowed for the tray is 2.5kg.
- Do not overload the tray; this could cause the tray to break or could cause the chair to become unstable.
- Always turn off the power to the controller before moving the tray out of the way.
- Do not leave lit cigarettes or other heat sources on the tray as this could cause the tray to deform and mark.
- Ensure that all extremities and clothing are free when positioning the tray for use.
- Ensure that you always have comfortable access to the controls whilst the chair is moving and make sure that there is nothing on the tray that could interfere with your control of the chair.

10.6 Swing-away tray mounted centre control (R-net)

The swing-away tray mounted centre control enables the hand control to be flipped over, providing a flat surface when the tray is required and back around when the user requires access to the hand control

NOTE: All warnings for the flip up version are the same as the normal version (section 10.4 above) with the following additional warnings:

WARNING!

- Make sure that the controller is turned off before it is flipped over

NOTE: Be aware that when the controller is flipped to the underside of the tray that driving will be inhibited for the user's safety.

 Centre bar mount with R-net Control
Please refer to the R-net Owner's Manual for details of R-net hand control functions.

10.7 Forus control (R-net)

WARNINGS!

- Ensure that you set the speed of the forus control to a speed that you can comfortably follow.
- Ensure that you always have comfortable access to the controls whilst the chair is moving and make sure that the controller is fixed securely to the chair.
- It is important that the joystick boot is replaced if it is torn or brittle; failing to do so could cause substance damage to the controller and unexpected movement of the chair.
- Always turn off the power to the controller when leaving the user in the chair.
- Do not replace the joystick knob with any unauthorised item. It may cause hazardous operation and loss of control of the chair.
- Do not hang any items on the handles of the forus control.

The forus attendant control is a mechanical device that translates mechanical attendant movements into joystick movements on a regular remote control. (Fig 10.3)

The forus attendant control operates with R-net controls only.

 **Forus with R-net Control**
Please refer to the R-net Owner's Manual for details of R-net hand control functions.

After switching on the hand control, the forus attendant control is ready to use. Pushing the handle downwards drives the wheelchair backwards, pushing the handle upwards drives the chair forwards. A left or right push drives the chair in the respective direction.

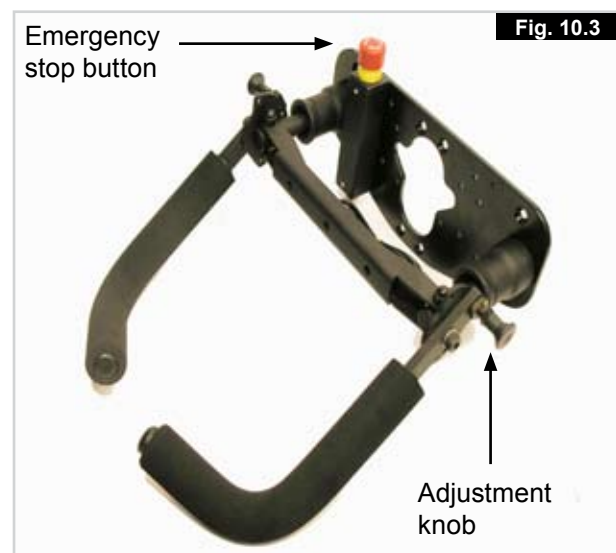

The forus push handle mechanism is centred with springs which will always bring it back to its centre position when the attendant's hands are taken off the handles. The push handles can be adjusted in height by releasing the spring loaded pin on the side, adjusting to the right height position and releasing the pin. (Fig 10.3)

10.7.1 Emergency stop button

The forus attendant control is equipped with an EMERGENCY STOP button (Fig 10.3). When pressed, it brings the chair to a controlled stop.

When the button is pressed, it automatically locks mechanically in that position. To release twist and pull the EMERGENCY STOP button until it locks into the off position. The chair can now be switched on.

NOTE: Always move the chair with care. If the programming of the attendant drive profile(s) needs adjustments to make it more convenient for the attendant and/or the person sitting in the wheelchair please contact your Sunrise Service agent for adaptation.

If the direction of movement of the forus attendant control needs to be altered please contact your authorised Sunrise Medical dealer for adaptation.

10.8 Powered swing away arm (R-net)

This option (Fig 10.4) is used to mount all chin controls or the sip and puff and can be operated by either a buddy button or ribbon switch

 **WARNING!**

Please be aware of your surroundings before operating the swing-away arm. Make sure that you have sufficient room to your side to prevent damage to your control device and to prevent injury to others.

 **WARNING!**

Please be aware that it is possible to accidentally operate your swing-away arm whilst you are driving your chair. Make sure that you are comfortable with the position of your control switch before using your chair

The powered swing away operates with R-net controls only.

Powered Swing-away with R-net Chin Control

 Please refer to the R-net Owner's Manual for details of R-net hand control functions

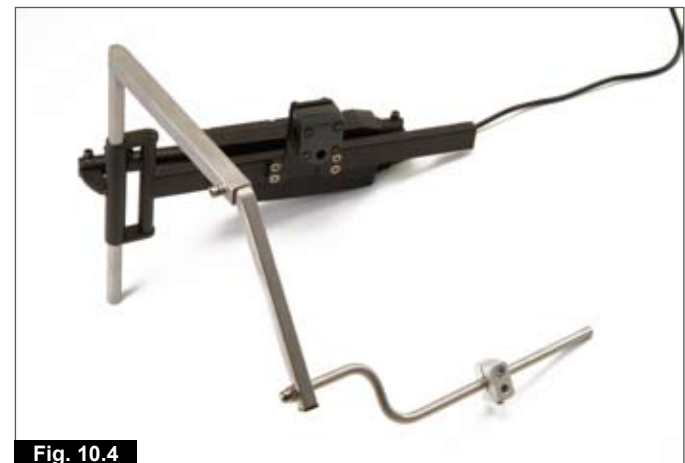

Fig. 10.4

11.0 Speciality Controls

11.1 Proximity head array

WARNINGS

- The sensors used in this product will operate if moisture of any substance that is electrically conductive is present in sufficient quantities.
- Electro magnetic interference from electrical power lines and certain types of phones will cause the sensors to activate.
- These sensors are capacitive in nature and any material that is conductive will activate them. These sensors are electronic sensors and generate an electronic field which can be affected by liquids and radio frequency interference.
- If the user is caught in the rain or some type of liquid is spilled on the sensor pad, the chair has a great potential to act erratically. Try to activate the stop sensor or shut the chair down if possible.
- Avoid use under high power lines and around cell phones which will interfere with the electronic field generated by the sensor.
- A warning must be conveyed to the wheelchair operator that the chair could come to a sudden stop or act in an erratic manner due to liquids or radio frequency interference (RFI).
- Most electronic equipment is influenced by (RFI). Caution should be exercised with regard to the use of portable communication equipment in the area around where the sensors are located in the head array. If RFI causes erratic behaviour, shut the wheelchair off immediately. Leave off while transmission is in progress.

11.2 Driving with the head array (Fig 11.1)

The head array uses 3 zero touch sensors for driving, one in each head pad.

The sensor in the centre of the headpiece controls forward and reverse.

Sensors in the right and left headpieces are for right and left directional motion respectively.

The fourth switch is your mode switch and it toggles the head array between forward and reverse and between driving the wheelchair and operating any ancillary devices (such as powered seating or augmentative communications systems.)



Fig. 11.1

Switching modes

A variety of mode switches are available. These can be divided into three types: internal, hardware mounted and external.

- Internal: mode in left pad or right pad
- Hardware mounted: beam switch
- External: fibre optic, button or mode jack 2. All mode switches perform the same tasks.
- Single click of the mode switch will toggle between forward and reverse.
- A double click of the mode switch will change the operating mode of the system. e.g. standby to drive to actuator etc.

For further details refer to the user manual supplied with your module or contact your Sunrise Medical authorised dealer

11.3 Proportional head control

Operation of the head control (Fig 11.2)

1. The drive is based on displacement of the headrest. A small amount of pressure must be exerted on the headrest to generate results.
2. Neutral position is when the headrest is not displaced.
3. When the headrest moves right or left, the chair will move in the respective direction.
4. For forward or reverse the headrest needs to be displaced in a backwards direction. Use of the mode switch selects the direction of movement. This will be displayed on the enhanced display module.
5. The greater the displacement of the headrest from the neutral position the faster the chair will go.

For further details refer to the user manual supplied with your module or contact your Sunrise Medical authorised dealer.



Head Controls

Please refer to the R-net Owner's Manual for details of R-net hand control functions



Fig. 11.2

11.4 Sip and puff control and buddy buttons

WARNINGS

- Do not wrap the cable around the switch, wrap the cable separately
- Do not pull on the cable of the switch
- Do not overload your switch connection, adhere to maximum current ratings
- Do not immerse the switch in water
- Do not open or attempt to fix switch
- Do not use solvents to clean your switch, use only a damp cloth or alcohol. The pneumatic tube of the sip and puff can be sterilised in a gas autoclave
- Do not expose switch to extreme heat or cold



For further details refer to the user manual supplied with your module or contact your Sunrise Medical authorised dealer



Sip and puff (Fig 11.3).

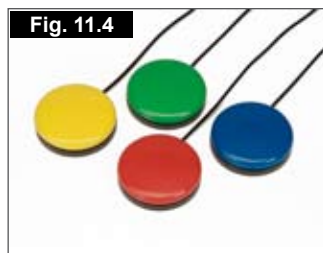

Buddy buttons (Fig 11.4)

11.5 HMC mini joystick as a chin control or hand control

The HMC mini joystick (Fig .11.5) is a small joystick which can be handled with little strength (<10 gr.) and little movement.

The HMC mini joystick can be adjusted to the needs of the user via 2 extra handles (Fig.11.6). In combination with mounting kit it's possible to manipulate the mini joystick by finger, hand, tongue, chin, etc.

The joystick is completely protected against moisture, which makes it suitable to use outdoors and when the joystick isn't used for long periods a hood can be placed over it (Fig.11.7). This will give extra



11.6 Proportional chin control (Fig.11.8)

The proportional chin control must be used in conjunction with the Omni Plus module. This is to give visual feedback for the selection of drive profiles and seating options.

WARNING!

- Do not replace the joystick knob with any unauthorised item. It may cause hazardous operation and loss of control of the chair.
- It is important that the joystick boot is replaced if it is torn or brittle; failing to do so could cause substance damage to the controller and unexpected movement of the chair.
- Ensure that you always have comfortable access to the controls whilst the chair is moving and make sure that the controller is fixed securely to the chair.



11.7 Micro pilot Joystick

The Micro Pilot joystick is a miniature joystick based on a different technology than other mini "throw" based joysticks. As little as 10 grams of force with virtually no joystick deflection will activate the chair. All internal metal construction means outstanding durability, (Fig 11.9).



R-net, Omni Plus control

Please refer to the R-net Owner's Manual for details of R-net, Omni Plus control functions

12.0 Batteries and charging



WARNING!

- Please read the owner's manual with the charger supplied carefully. The general procedures and effects for the interference with the chair and the batteries remain valid.
- Do not expose any part of the battery to direct heat (i.e. naked flame, gas fire).
- When charging always place your charger on a hard surface in a room with good ventilation.
- You should not charge your batteries in outdoor conditions.

12.1 Batteries

The batteries are contained within the drive unit located under the battery shroud.

To remove the batteries first release the two handle screws under the front of the seat frame (Fig. 12.1), (Fig.12.2 MWD), which connect the seat frame with the seat module interface.

Flip the seat frame backwards until the automatic lock pin clicks to secure it in place, (Fig. 12.3 and 12.4). Ensure the seat is secure before letting go.

Lift off the battery box lid.

Disconnect the 2 pin Anderson connectors from each battery (Fig.12.5 and 12.6).

There are straps available on each battery to facilitate lifting them out. Remove the front battery first.

To fit the batteries reverse the above procedure.

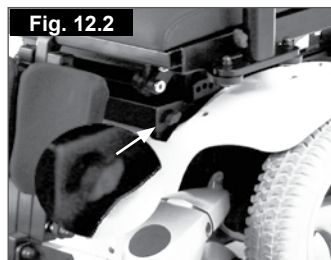
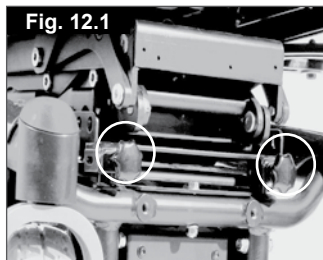

12.2 Safety cut-outs

In the event of a short circuit there are several safety systems built into your wheelchair to safeguard your electrical circuits, (Fig.12.7).

1. Fusible 150A links are connected into the battery harnesses to protect the batteries and wiring.
2. 15A auxiliary power circuit fuses for auxiliary modules and the Recaro seat power supply

To replace them contact your Sunrise Medical authorised dealer, who will also diagnose the fault.

12.3 Common battery statements

Over the years, battery technology has moved forward but, unfortunately, some of the advice given on battery care has not. This has resulted in a number of confused and at times contradictory instructions on the 'best' way to care for your batteries.

This section will help to dispel some of these myths and legends.

Batteries are the power source for almost all of the modern mobility products available today. The design of batteries used in mobility products is significantly different to the batteries used to start a car for example. Car batteries are designed to release a large amount of power over a short period of time, whilst mobility batteries (commonly called deep cycle batteries) release their power evenly, over a long period of time. Therefore, due to the lower production volumes and increased technological requirements, mobility batteries are typically more expensive.

Commonly two 12 volt batteries are used together in a mobility product, giving a total voltage of 24 volts. The size of the battery (e.g. its available power) is expressed in amps per hour e.g. 70amp/hr. The higher the number, the bigger the battery size, weight and, potentially, the greater the distance you can travel. Sunrise Medical only fit as standard maintenance free batteries into these types of wheelchairs.



CAUTION!

Do not fit car batteries to the wheelchair. Fit only deep cycle, maintenance free mobility batteries.

When the batteries are worn out, take them to the local authority disposal point.

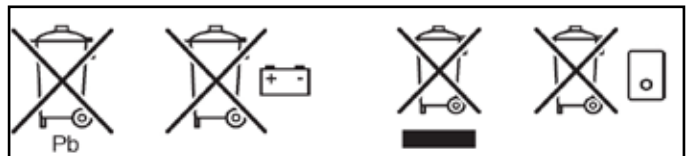

12.4 Maintenance free batteries

This type of battery uses a method of carrying the electrolyte commonly referred to as 'gel', that is held within the battery case. As the name implies, no maintenance is required other than regular charging. You can safely transport this type of battery without fear of acid spilling. Furthermore, they are approved for transportation on aircraft, trains and ships.

12.5 Battery care

Below is set out a battery care plan for maintenance free batteries. This has been agreed between Sunrise Medical and the battery manufacturers, to enable you to get the best out of your batteries. If a different care plan is followed, this may result in lower than expected performance from your mobility vehicle.

12.6 Maintenance free battery care plan

⚠ CAUTIONS!

1. Only use an approved Sunrise Medical charger compatible with the vehicle to be charged.
2. Charge your batteries every night, regardless of the amount of use your mobility device has had during the day.
3. Do not interrupt the charging cycle.
4. If your mobility device is not required for use, it should remain connected to the charger until required. This will not damage your batteries, as long as the mains socket/plug is left switched on. Turning the mains socket/plug off, but leaving the mains cable plugged in will eventually deplete your battery charge.
5. If you leave your vehicle for an extended period (more than 15 days) charge the batteries fully and then disconnect the main battery lead.
6. Failure to allow for recharge will damage the batteries and can lead to shortened distances and premature failure.
7. Do not top up the charge of your batteries during the day. Wait until the evening for a full overnight charge.
8. As a general rule, maintenance free batteries take longer to fully charge than "wet" lead acid batteries.
9. The battery terminals need to be checked regularly for signs of corrosion. If any corrosion is apparent, then clean the terminals completely and re-grease the terminal using Vaseline petroleum jelly, not ordinary grease. Ensure that the terminal nut and bolt, cable clip and exposed cable are completely covered with jelly.

10. Following all the points above should result in a healthier battery, greater range for the vehicle user and a longer life for your batteries.

11. Return the batteries back to Sunrise Medical or directly to the battery manufacturer for recycling, when they no longer hold charge.

12.7 General charger information

The external charger has been designed to charge two 12V Gel type batteries connected in series (= 24 V).

12.7.1 Charger safety features

The chargers have features which prevent hazards or accidents occurring as a result of connecting batteries the wrong way round, overheating caused by fault conditions or attempting to charge wrong voltage batteries.

The majority of charger sizes are electrically double insulated and no earth connection is required. Some larger sizes may be electrically earthed and this will be clearly stated on the label.

The 3 pin UK mains input plug contains a replaceable fuse. The rating of this fuse is shown on the charger label.

⚠ DANGER!

- As with all mains powered electrical equipment, always replace blown fuses with the same type and size of fuse as specified.
- Fitting of different fuses can result in an increased fire risk, damage to the charger or failure of the charger to operate properly.

If your charger has been specified for use in Continental Europe it will contain a European two pin plug which does not have a fuse. In this case the fuse is located in the fascia panel of the charger.

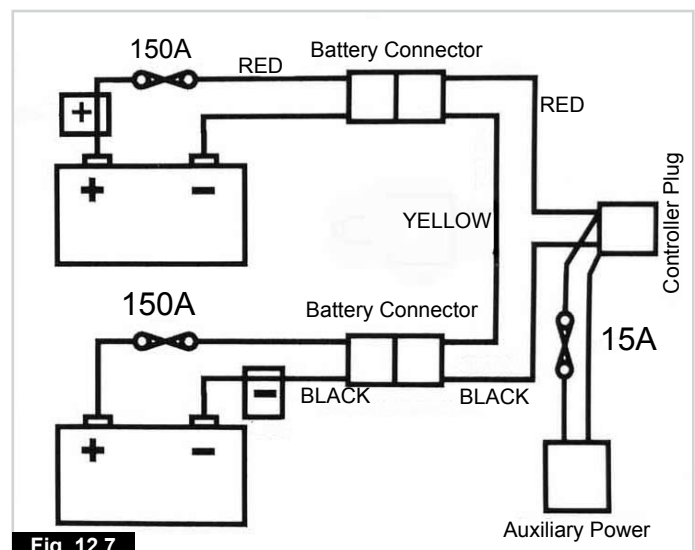

Fig. 12.7

12.7.2 Procedure for connecting the charger and charging

- Connect the battery charger round output plug to the charging socket on the front of the joystick module, (Fig. 12.8-12.10).
- Connect the charger to the mains supply by means of the mains plug and switch on.
- The GREEN light will flash to show power is on and the charger is initialising.
- The ORANGE light comes on to show that the batteries are charging.
- Flickering between ORANGE and GREEN shows that charge is almost complete.
- Solid GREEN indicates charge is complete.



For more information about the charger operation, consult the instructions provided with the charger.

NOTE: If the charger is not connected to the wheelchair, it does not output charge voltage.

The charger may be used with other brands of Gel type batteries, subject to written confirmation from the Technical Department of Sunrise Medical.

DANGER!

- An extension cord should not be used unless absolutely necessary. Use of an improper extension cord could result in a risk of fire and electric shock.
- If any extension cord must be used, make sure the pins on the plug of the extension cord are the same number, size and shape as those of the plug on the charger; and that the extension cord is properly wired and in good electrical condition.

WARNING!

- Always switch off at the mains before disconnecting the batteries.
- The charger is designed for indoor use. Do not use outdoors or expose to rain, snow, spray or moisture.

CAUTION!

When buying replacement batteries or charger always consult your Sunrise Medical service agent. Do not leave the charger connected to the battery with the mains disconnected or switched off. This could result in damage to your battery being caused by deep discharge over a period of time.

To reduce the risk of damage to electric plug and cord, pull by the plug rather than the cord when disconnecting the charger.

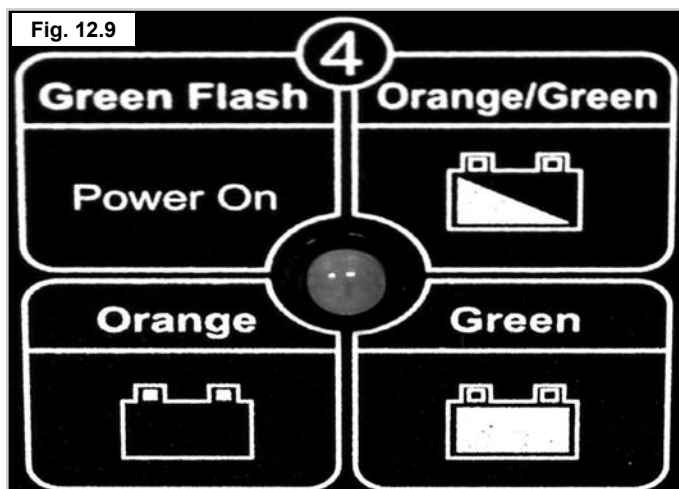
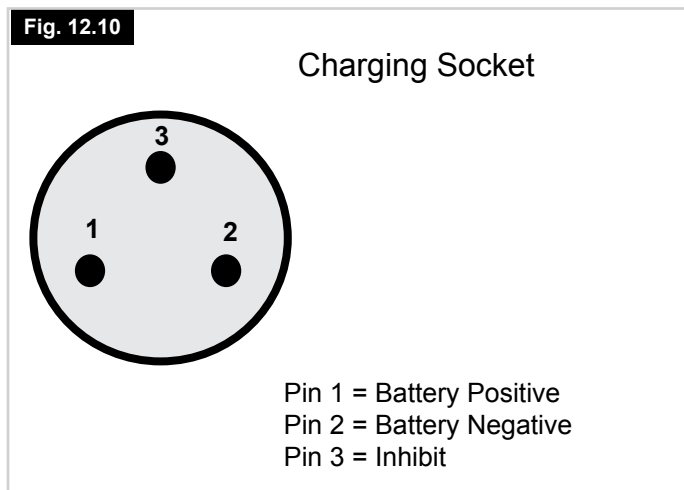



WARNINGS!

- Make sure the cord is located so that it will not be stepped on, tripped over or otherwise subjected to damage or stress.
- Do not rest a battery on top of the charger.
- Do not stand the charger on a carpet or other soft surface. Always place it on a hard flat surface.
- Do not operate the charger if it has received a sharp blow, been dropped or otherwise damaged in any way. Take it to a qualified technician.
- Never place the charger directly above the battery being charged; gases from the battery will corrode and damage the charger.
- Never charge a frozen battery. A fully charged battery will rarely freeze but the electrolyte of a discharged battery can freeze at -9° Centigrade. Any battery that is suspected of being frozen should be thawed completely before charging.
- Never sit with the charger on your lap when charging your batteries
- The charger casing will get hot during its normal operation.
- Do not disassemble charger; only have it repaired by the manufacturers. Incorrect re-assembly may result in a risk of electric shock or fire.
- To reduce the risk of an electric shock, unplug the charger from the outlet before attempting any maintenance or cleaning. Turning off the controls will not reduce the risk.
- Never smoke or allow a spark or flame in the vicinity of battery or charger.
- Be extra cautious to reduce the risk of dropping a metal tool onto the battery. It could spark or short circuit the battery or other electrical parts that may cause an explosion. Also take off all personal metal effects and dangling objects when working on the battery.

12.8 The range of your vehicle

Please refer to the specification tables at the back of this manual for Energy Consumption, (Maximum Range), information.

Most manufacturers of mobility products state the range of their vehicles either in the sales literature or within the Owner's Manual. The range stated sometimes differs from manufacturer to manufacturer even though the battery size is the same. Sunrise Medical measure the range of their vehicles in a consistent and uniform manner, but variances still occur due to motor efficiencies and overall product load weight.

The range figures are calculated to I.S.O. Standard 7176. Part 4: Wheelchair Energy Consumption Theoretical Range

This test is carried out in controlled conditions with new, fully charged batteries, on a level test surface and a user weight of 100 kg. The range figures stated should be seen as a theoretical maximum and could be reduced if any single, or combination, of the following circumstances occur:

- User weight heavier than 100 kg.
- Batteries whose age and condition are less than perfect.
- The terrain is difficult e.g. very hilly, sloping, muddy ground, gravel, grass, snow and ice.
- The vehicle climbs kerbs regularly.
- The ambient temperature is very hot or very cold.
- Incorrect tyre pressures in one or more tyres.
- Lots of start/stop driving.
- Also thick pile carpets within the home can affect range.
- Use of additional power consumption options (e.g. light, actuators, etc.)

The battery sizes available on each Sunrise Medical product should give sufficient range to cope with the majority of customer's lifestyles.

12.9 Battery warranty

Battery warranties are subject to periods set by the manufacturers. However, most of these warranties are subject to a wear and tear clause, and if you genuinely wear out your batteries in 6 months, it will not be possible to obtain a replacement under warranty.

13.0 Transportation

A wheelchair secured in a vehicle will not provide the equivalent level of safety and security as a vehicle seating system. Sunrise Medical recommends that the user transfers to the vehicle seating and uses the vehicle-installed restraint system wherever possible. Sunrise Medical recognises that it is not always practical for the user to be transferred and in these circumstances, where the user must be transported whilst in the wheelchair, the following advice must be followed:

13.1 Transportation Warnings

⚠ WARNING!

- Confirm that the vehicle is suitably equipped to transport a passenger in a wheelchair, and ensure the method of access/egress is suitable for your wheelchair type. The vehicle should have the floor strength to take the combined weight of the user, the wheel chair and accessories.
- Sufficient space should be available around the wheelchair to enable clear access to attach, tighten and release the wheelchair and occupant tie down restraints and safety belts.
- The occupied wheelchair must be located in a forward facing position and secured by the wheelchair tie down and occupant restraint straps (WTORS tie downs meeting the requirements of ISO 10542 Part 2 or SAE J2249) in accordance with the WTORS manufacturer's instructions. Refer to the section 'Tie Down Instructions' for further information on transporting your wheelchair.
- The wheelchair's use in other positions within a vehicle has not been tested e.g. transportation in a side facing position must not be carried out under any circumstances. (Fig 13.1).

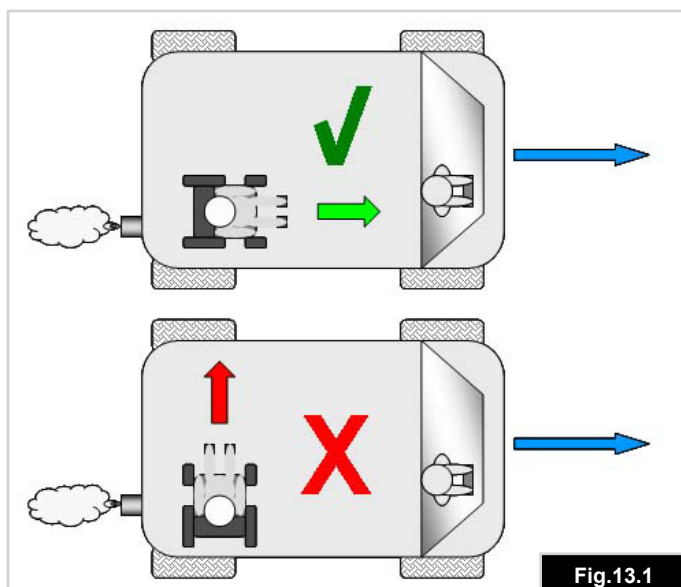

⚠ DANGER!

- Alterations or substitutions must not be made to the wheelchair securement points or to structural and frame or components without consulting the manufacturer. Failure to do so will invalidate the ability of the wheelchair to be transported within a vehicle.

The wheelchair should be inspected by a Sunrise Medical authorised dealer before re-use following involvement in any type of vehicle impact.

⚠ DANGER!

- Both pelvic and upper torso restraint belts must be used to restrain the occupant (Fig 13.2) to reduce the possibility of head and chest impacts with the vehicle components.

NOTE: This wheelchair has been successfully crash tested with the Unwins headrest. Sunrise Medical recommends that you use a suitably positioned headrest when being transported in the wheelchair. However it is highly recommended that as a preference you transfer from your wheelchair to a seat within the motor vehicle.

⚠ WARNING!

- Postural supports (lap straps, lap belts) should not be used or relied on for occupant restraint in a moving vehicle unless they are labelled as meeting the requirements specified in ISO 7176-19:2001 or SAE J2249.
- Spill proof sealed batteries such as "gelled electrolyte" must be installed on powered wheelchairs when used in a motor vehicle.

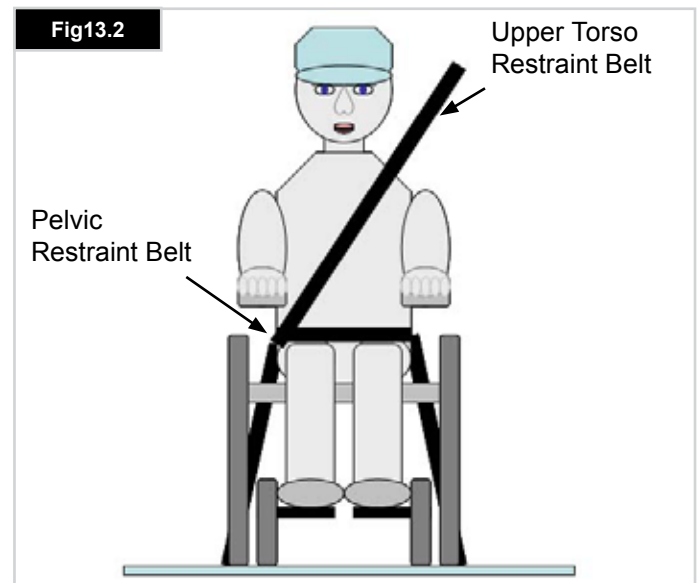

Due to the weight of the Jive wheelchair it is always necessary to use a 6 strap tie down system, 4 straps at the rear of the wheelchair and 2 at the front. A representative FWD/RWD and MWD Jive wheelchair has been tested in accordance with the dynamic performance requirements specified in ISO 7176-19:2008 "Wheeled Mobility Devices for use in Motor Vehicles". The 6 point strap restraint system, 4 straps at the rear and 2 straps at the front, conforms to ISO 10542 or SAE J2249 and was used in accordance with the WTORS manufacturer's instructions. The Unwins TITAN 1 restraint system was used for these tests. However other 6 strap restraint systems may be used as long as they conform to ISO10542 or SAE J2249 and are used in accordance with the WTORS manufacturer's instructions. They must also be checked to make sure that they are sufficiently specified for the weight of the wheelchair and rider

NOTE: In order to restrain the wheelchair effectively using a six point strap system please ensure that the tie down straps are correctly tensioned as per the WTORS manufacturers instructions

⚠ DANGER!

- The tie-down restraints should be fitted to the main frame of the wheelchair as indicated by the diagrams in this section. Positioning of Tie down Restraints on the Wheelchair, and not to any attachments or accessories, e.g. not around the spokes of wheels, brakes or footrests.

⚠ DANGER!

- The tie-down restraints should be attached as close as possible at an angle of 45 degrees and tightened securely in accordance with the manufacturer's instructions.
- Alterations or substitutions must not be made to the wheelchair tie down points or to structural and frame or components without consulting the manufacturer. Failure to do so will invalidate the ability of a Sunrise Medical wheelchair to be transported within a vehicle.
- Both pelvic and upper torso restraint belts must be used to restrain the occupant to reduce the possibility of head and chest impacts with the vehicle components and serious risk of injury to the user and other vehicle occupants. (Fig.13.2) The upper torso restraint belt should be mounted to the vehicle "B" pillar - failure to do so will increase the risk of serious abdominal injuries to the user.
- A head restraint suitable for transportation (see label on headrest) must be fitted and suitably positioned at all times during transportation.
- The safety of the user during transportation depends upon the diligence of the person securing the tie down restraints and they should have received appropriate instructions and/or training in their use.
- Wherever possible remove and stow safely away from the wheelchair all auxiliary equipment, for example: Crutches, Loose cushions, Tray Tables, etc.
- Articulating/elevating leg rest should not be used in the elevated position when the wheelchair and user are being transported and the wheelchair is restrained using Wheelchair Transport and Occupant Restraints.
- Reclining backrests should be returned to an upright position.
- The manual brakes must be firmly applied.

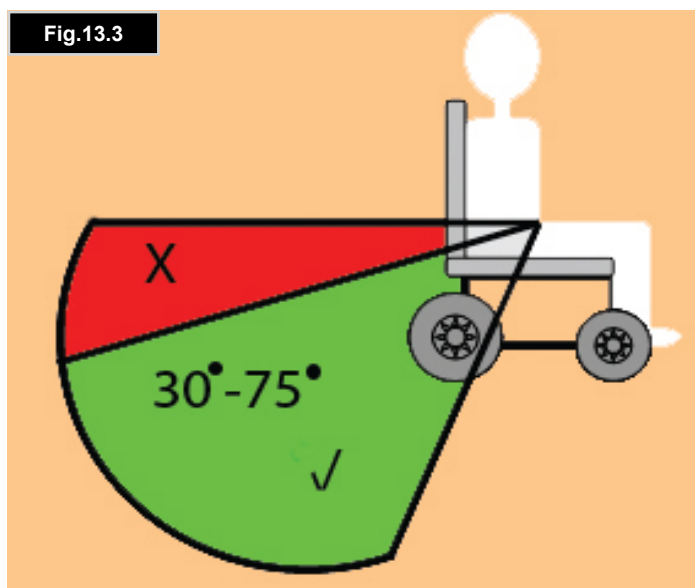

Fig.13.3

13.2 Occupant Restraint Instruction:

- The pelvic restraint belt must be worn low across the front of the pelvis so that the angle of the pelvic belt is within the preferred zone of 30 to 75 degrees to the horizontal.
- A steeper (greater) angle within the preferred zone is desirable i.e. closer to, but never exceeding 75degrees.(Fig.13.3).
- The upper torso restraint belt must fit over the shoulder and across the chest as illustrated Fig 13.5.
- Restraint belts must be adjusted as tightly as possible consistent with user comfort.
- Restraint belt webbing must not be twisted when in use.
- Restraints should be mounted to the vehicle “B” pillar and should not be held away from the body by wheelchair components such as armrest or wheels, (Fig.13.4).
- The tie down symbol (Fig.13.6) on the wheelchair frame indicates the position of the wheelchair restraint straps. The straps are then tensioned after the front straps have been fitted to secure the wheelchair.

Fig.13.6



13.3 Positioning of the Tie Down Restraints:

RWD Front Tie Down

Fig.13.7



RWD Rear Tie Down

Fig.13.8

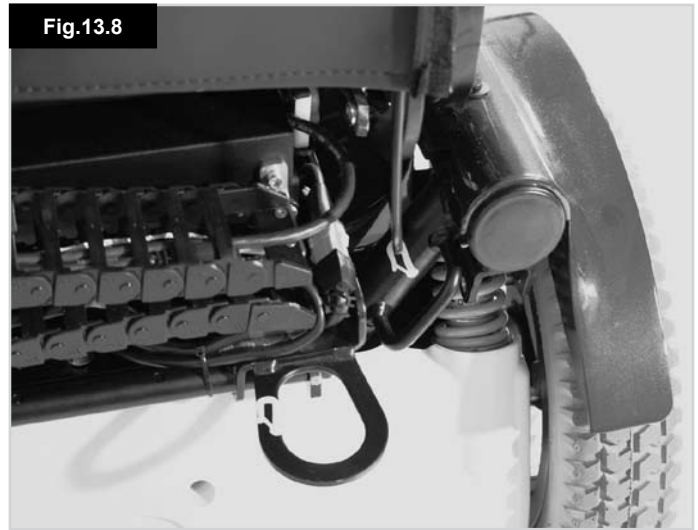

RWD Front and Rear Tie Down Straps

Fig.13.9



Fig.13.4

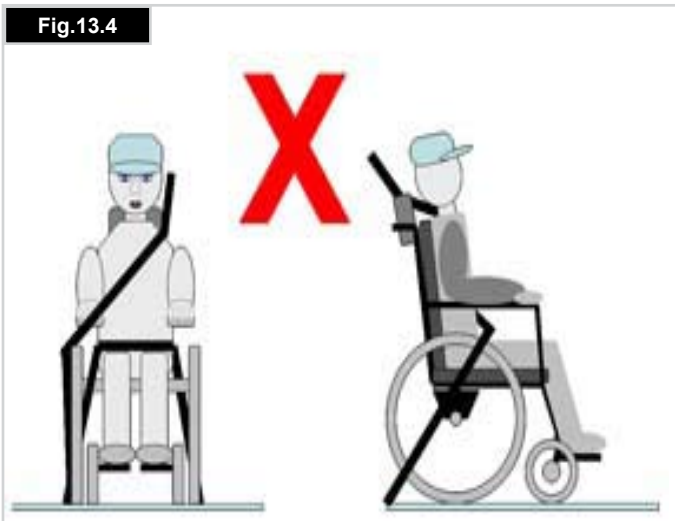
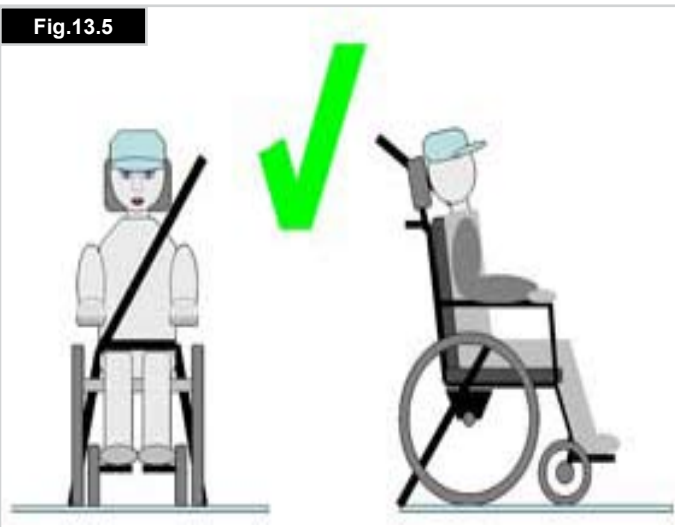

Fig.13.5



FWD Front Tie Down

Fig.13.10



MWD Front Tie Down

Fig.13.13



FWD Rear Tie Down

Fig.13.11

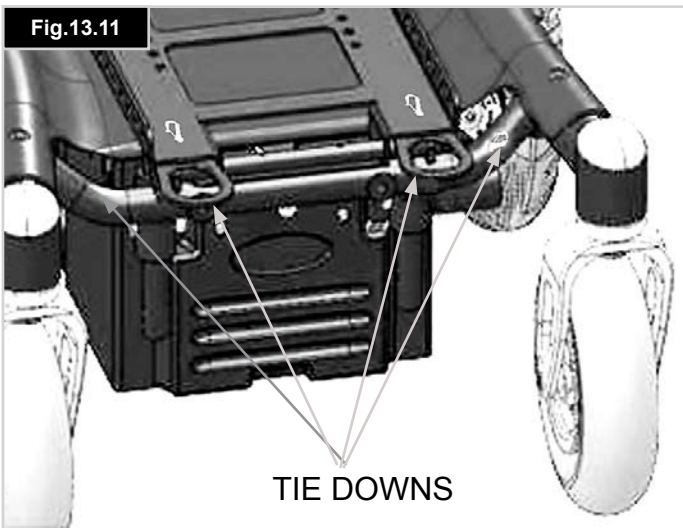

MWD Rear Tie Down

Fig.13.14



FWD Front and Rear Tie Down Straps

Fig.13.12

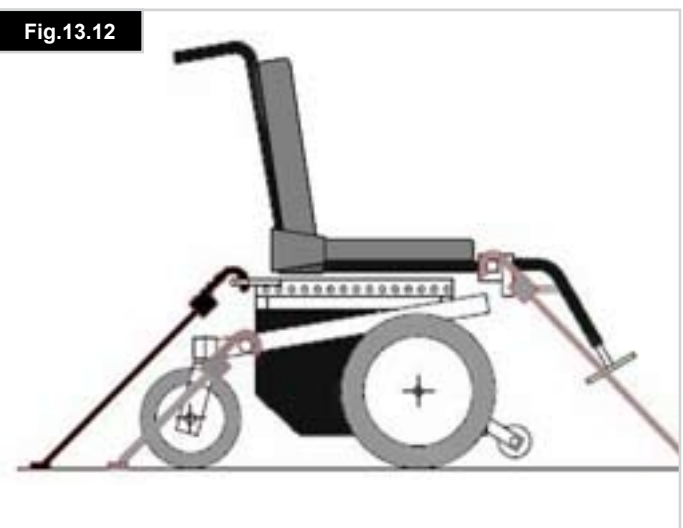

MWD Front and Rear Tie Down Straps

Fig.13.15



13.4 Leg Strap Fitting Instructions Adjustable Hangers

Part. No. 740130 LEG STRAP

For chairs with seat width up to 18"

Part. No. 740132 LEG STRAP 18-20 INCH

For chairs with seat width greater than 18" Or all chairs with width adjustable hanger.



1. Fit strap around the actuator shaft to run behind your calf pads, (Fig.13.17).



2. Fit the second side like no. 1, (Fig.13.18).



3. Tension should be sufficient to prevent removal of the ELR ALR via the swing-away motion, (Fig.13.19).



13.5 Special shipping requirements:

The wheelchair may be transported by road, rail, sea or air and the batteries conform to IATA regulations.



CAUTION!

Before you travel, please contact the appropriate carrier. The travel operator will be able to supply details of any special requirements/instructions.

Ensure that any detachable parts are secured with your mobility aid or separately packed and labelled so they do not get lost during loading and unloading.

Take this Owner's Manual with you and if fitted take the R-net Owner's Manual also.

The carrier will need to refer to the following sections.

How to lock/unlock the Joystick, (Section 7.3), (Section 4.32 R-Net Owners Manual).

How to disconnect the batteries, (Section 12.1).

How to disconnect the drive, (Section 5.4).

13.6 Medium to long term storage:

When storing your wheelchair for long periods of time (in excess of one week), follow these simple instructions:

Fully charge the wheelchair for at least 24 hours. Disconnect the batteries or battery boxes.



WARNING!

- Never store your wheelchair;
- Outside.
- In direct sunlight, (plastic parts may discolour).
- Near a source of direct heat.
- In a damp environment.
- In a cold environment.
- With the batteries/battery boxes connected, (even if the controller is switched off).

Avoiding all of the above will minimise battery deep cycle discharge and extend battery lifetime.

When returning the wheelchair to use, please reconnect the batteries/battery boxes and charge the wheelchair for at least 24 hours before use.

14.0 Maintenance and Cleaning

CAUTION!

It is important that you follow the following cleaning and maintenance schedule in order to keep your wheelchair in tip top condition.

14.1 Tyre maintenance and pressures

14.1.1 Tyre pressure

CAUTION!

If pneumatic tyres are fitted to your wheelchair it is important to regularly check the air pressure and for signs of wear.

The correct pressures are between the minimum of 137 kiloPascals (20 psi, 1.37 bar) and the maximum 241 kiloPascals (35 psi, 2.41 bar) for rear and front wheels (see side of tyre).

The pressure will need to vary, depending on the weight of the user.

NOTE: It is important that front wheels are inflated to equal pressures as a pair, and likewise the rear. The inflator pump provides the safest method of inflating your wheelchair tyres and the pressure can be checked with a standard motor vehicle pressure gauge.

DANGER!

- Do not inflate beyond the maximum allowed tyre pressure.
- Always use the pump that is supplied with the chair,
- Never use a forecourt pump

14.1.2 Tyre wear

When inspecting the tyres for signs of wear, look for significant scuff marks, cuts and a diminished tyre tread. Tyres will need to be changed when the tread cannot be seen over the complete surface of the tyre, (Fig.14.1).



14.1.3 Drive wheel tyre repair

To remove the wheel/tyre:

Please see below and next page for photographs.

- Use a 8.0 mm hex key to loosen the 3-Socket studs, (Fig. 14.2).
- Jack the wheel up and support it using blocks,
- (Fig. 14.3).
- Remove the 3 studs and pull the wheel away from the hub.
- Remove the valve cap and let the air out of the tyre by gently pressing the valve stem with a small screw driver, (Fig. 14.4).
- There are 6 rim studs that must be loosened/ tightened in the number order shown, (Fig.14.5).
- Use a 5.0 mm Allen key to release/tighten the studs. (Fig. 14.5) .
- Lift the inner rim off the tyre wall (Fig. 14.6).
- Lift the tyre and tube off the outer rim, (Fig.14.7).
- Gently get a hold of the inner tube just behind the valve.
- Carefully feed the tube out of the tyre, (fig.14.8).
- Ensure all parts are clean before reassembling, (Fig.14.9).

To refit

- Place the tube inside the tyre and rest the tyre on the outer rim.
- Align the valve stem with the cut out in the rim.
- Face the valve stem outward.
- Place the inner rim over the tyre, tube and outer rim.
- Align the cut out to fit over the valve stem and match it up to the cut out in the outer rim, (Fig.14.10).
- Make sure the stud mounts are in line on both rims.
- Tighten the studs in the sequence shown in Fig.14.5, taking care not to pinch the tube.
- Slowly inflate to the pressures quoted in section 14.1.1 .
- Refit the wheel back onto the motor shaft and fix it safely with the 3 studs to a torque of 47Nm.

For solid tyres the sequence is the same, just discount the references to the inner tube and valve.



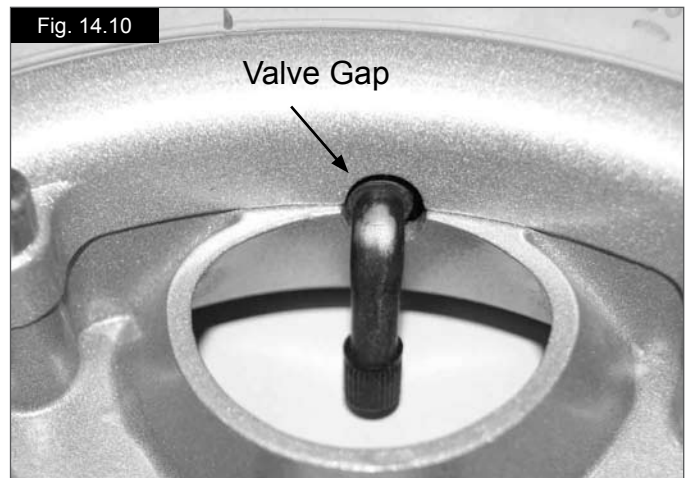
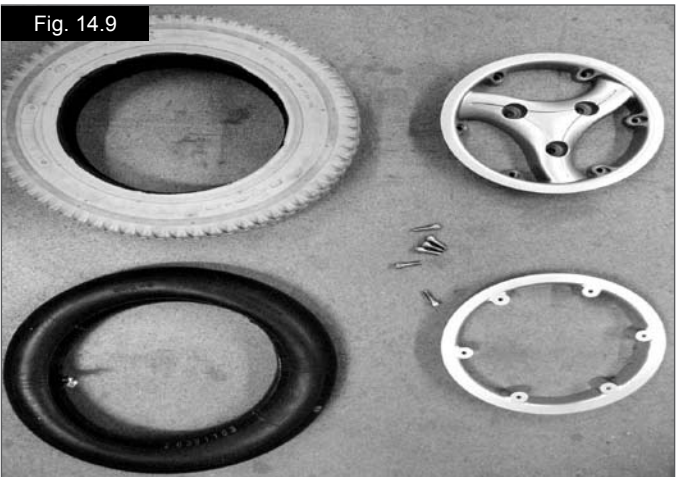
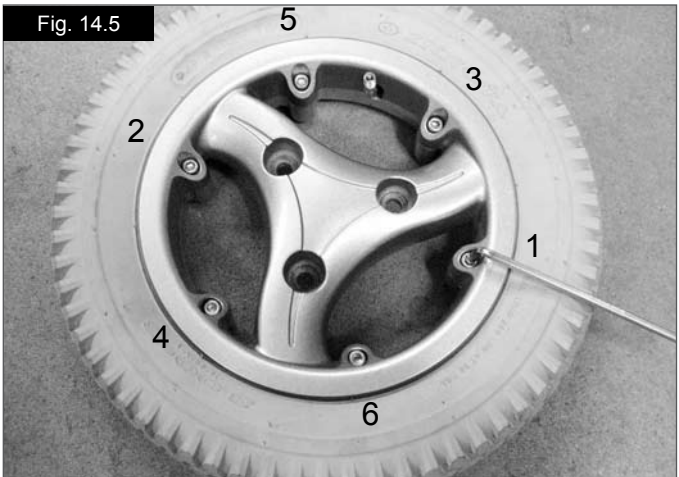
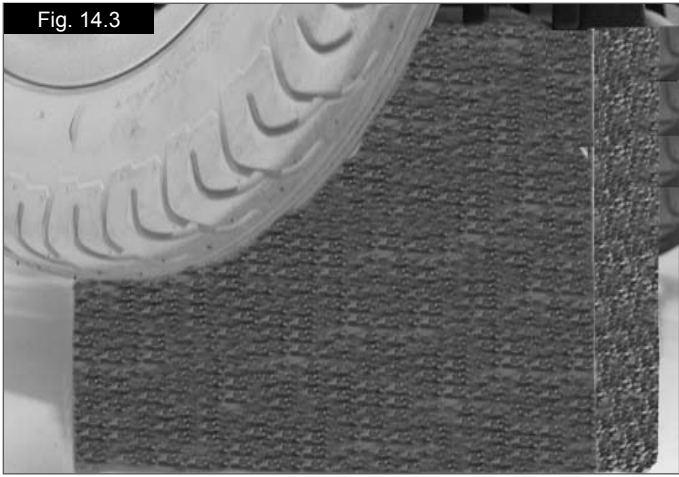

14.2 Removing the MWD castor wheel.

- Use a 13.0 mm spanner/socket to undo the axle bolt, (Fig.14.11).
- Remove the nyloc nut, (Fig.14.12).

Refitting:

When refitting do not try to force the bolt through. Gently move the wheel back and forth until the bolt slips through.



WARNING!

Always use a new nyloc nut when refitting.



14.3 Removing the RWD/FWD castor wheel.

Note the position of the castor & which hole is used to mount it. Ensure that both castors use the same mount position.

- Use a 5.0mm hex key remove the 2 axle studs, (Fig.14.13).
- Remove the centre spacers and spindle, (Fig.14.14).

For pneumatic tyres,

- let the air out of the tyre.
- Undo the 3 hub studs, (Fig.14.15).
- Lift the hubs out, (Fig.14.16).
- Gently feed the tube out of the tyre, (Fig.14.17)
- When refitting the hub studs, tighten to a torque of 15-20Nm.

Fig. 14.15



Fig. 14.13



Fig. 14.16



Fig. 14.14



Fig. 14.17

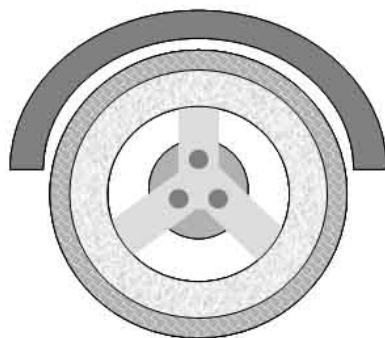

Knobby

OR



V-Groove

3.00 – 8 in.



FWD/RWD = 2.8/2.5 x 4 in, OR 3.00 x 4in.

MWD = 6 x 2in



14.4 Cleaning and your wheelchair

The wheelchair should be wiped over once per week with a slightly damp, not wet, cloth and any fluff or dust that has accumulated around the motors should be blown or dusted away.

CAUTION!

- Make sure that you dry all parts of your wheelchair if it becomes wet or damp after cleaning or if it is used in a wet or damp atmosphere.

WARNING!

- It is important that should the wheelchair be used by more than one person it is cleaned thoroughly to ensure there is no cross infection

14.4.1 Cleaning and inspection of your seating

WARNING!

- Tears, dents, wearing or slackening of upholstery particularly near to metal could result in poor posture or lower levels of comfort and pressure relief.

Cleaning instructions for Rehab (FXL) seating:

You can wash all parts of the covers with a gentle-wash detergent at 40°C. You can spin-dry the covers, but do not dry them in a dryer. You can remove all parts of the covers independently of each other and wash them separately. Take out the foam inlays prior to washing and close the Velcro fasteners!

Where upholstery cannot be removed, clean regularly to prevent build up or soiling. Clean with a damp soapy cloth however disinfectants may be used in dilution as specified by their manufacturer. Ensure surfaces are rinsed well with clean water and dried thoroughly.

Cleaning instructions for Jay/Jay Comfort seating:

Clean regularly to prevent build up or soiling. Clean with a damp soapy cloth and rinse well with clean water. Dry the surface thoroughly. A soft brush with soapy water may be used to remove stubborn dirt. Ensure surfaces are then rinsed and dried.

Some chemical colourings, e.g. ball point pen, food colourings or clothes dyes should be removed immediately to prevent long term staining.

CAUTION!

- Do not use solvents, bleaches, abrasives, synthetic detergents, wax polishes or aerosols.
- Disinfectants may be used in dilution as specified by their manufacturer.
- Ensure surfaces are rinsed with clean water and dried thoroughly.

Cleaning instructions for all and Recaro

CAUTION!

- You should remove stains on your seat as soon as possible.
- After a long period of use, you should clean the cover of your seat with a standard commercially available dry foam cleaning agent.
- You should always clean the whole surface and not just individual spots in order to avoid unattractive edges. The longer you wait the more difficult it will be to remove them.
- Avoid powerful rubbing with aqueous solutions. This will roughen up cover fabric.
- Dirt stains (eg. beer, blood, cola, red wine etc) are best removed with the dry foam cleaning agents or with a mild-action detergent.
- Please follow the respective instructions for use when treating the covers.
- The covers should be allowed to dry for at least 48 hours after cleaning with foam cleaning agents.
- Grease stains (eg. ballpoint pen, lipstick, chewing gum etc). Use a proprietary stain remover. Carefully rub the soiled location on the surface only with a clean cloth impregnated with the stain remover.
- Use only a very small quantity of stain remover.
- Test a small inconspicuous area first.
- The upholstery material must not be saturated, since the stain remover might then attack it and destroy it.
- Do not use a hose or a pressure washer to clean your chair.

WARNING!

- Always read the label on any commercial or domestic cleaning substances.
- Always follow the instructions carefully.

General cleaning

All parts/ accessories such as swing away trays should be cleaned with a damp cloth.

All lateral supports, headrest, armrests, side- guards, calf pads, lap belts and kneepads should be cleaned with a damp cloth.

14.4.2 Cleaning controls

Should the control of your wheelchair become soiled or dirty, it can be wiped with a damp cloth with a dilute disinfectant until clean.

WARNING!

This is important should the wheelchair be used by more than one person to ensure there is no cross infection.

Speciality controls

WARNING!

Ensure that wafer boards, joysticks (all variants), head arrays and switches (all variants) are cleaned with a mild disinfectant and a cleaning cloth to avoid any cross infection possibilities. Following removal from chair regularly wash the sip and puff mouth piece and tube to maintain cleanliness and functionality.

WARNING!

Ensure control is switched off before cleaning.

14.5 Lighting bulb exchange procedure

If the bulbs of your lights and indicator system show a defect, indicated through a double speed flash of the indicating LED on the hand control, please proceed in the following way:

Front and Rear Lights, (Bulb) :

(Refer to Fig.14.18 - 14.20).

- Use a flat bladed screwdriver to gently lever off the plastic cover.
- Lift the cover away carefully.
- Use a cross blade jewellers screwdriver to undo the small lamp cover screw.
- Carefully lift the lamp cover off. Take care not to loose the screw.
- The lamp is a 5W - 12v, 90° bayonet fit.
- The lamp, lamp cover and screw.

Front and Rear Lights, (LED):

For the LED lights and indicators, specific 12V clusters using an E12 thread are required.

Please contact your approved Sunrise Medical dealer for spares.

NOTE: Use Sunrise Medical authorised spare parts only. Be advised that all lighting circuits are electronically protected. In the event of a short circuit current will be limited to a safe level. Once the fault is removed the system resets automatically.



Fig. 14.19



Fig. 14.20



14.6 Electrical connections

When inspecting electrical connections, pay attention to the battery connections, the connection of batteries to power loom and plug in sockets for the joystick, control box and lights and indicators.

14.7 How to connect the cables to the batteries

WARNING!

If you are in any doubt about performing any maintenance on your wheelchair, please contact your Sunrise Medical authorised dealer.

Parts in the battery box:

- Two 12v Deep Cycle Mobility Batteries.
- Two Fused Battery Loom Assemblies.
- One Power Loom

WARNING!

- Before connecting the batteries it is very important to identify the correct connection for each battery terminal. Failure to do this may result in the wheelchair not functioning or possibly a blown fuse.
- Connect all battery terminals before connecting the plugs.
- After connecting battery terminals and connectors ensure all wiring is tidy and can not get entangled in any moving parts and the rubber covers fit fully over the battery terminals.

NOTE: After connection of the batteries wait 2 minutes for the system to reset, before switching on the control system. This reset time is required every time the batteries are disconnected.

Connecting / Disconnecting the Batteries:

- Undo the two seat interface screws, (Section 12.1).
- Flip the seat frame backwards until the automatic lock pin clicks to secure it in place. Ensure the seat is secure before letting go, (Fig.14.21).
- Lift off the battery box lid, (Fig.14.22).
- The Front battery has RED to Positive (+) & BLACK to negative (-). (Fig.14.23 - 14.24).
- The Rear battery has RED to Positive (+) & BLACK to negative (-). (Fig.14.23 - 14.24).
- Connect the GREY plugs to the power loom, (Fig.14.25 - 14.26).

WARNING!

Ensure the two seat interface screws are fully tightened before using the wheelchair, (Section 12.1, Fig.12.1).

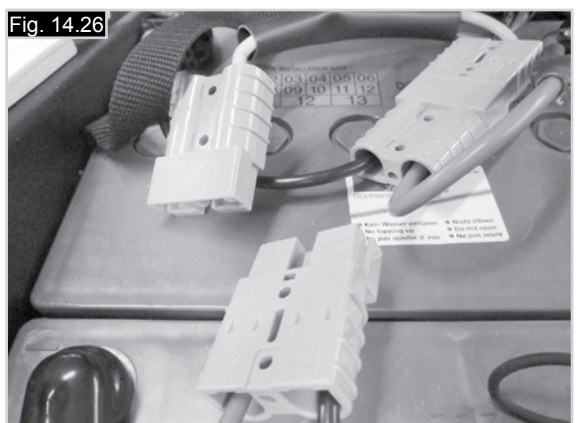
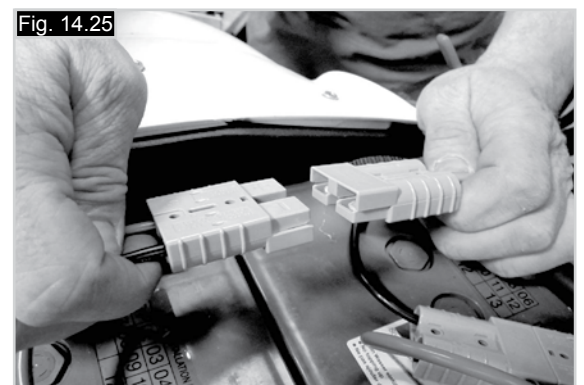
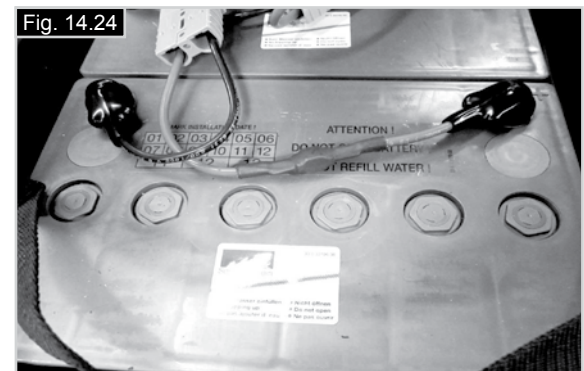
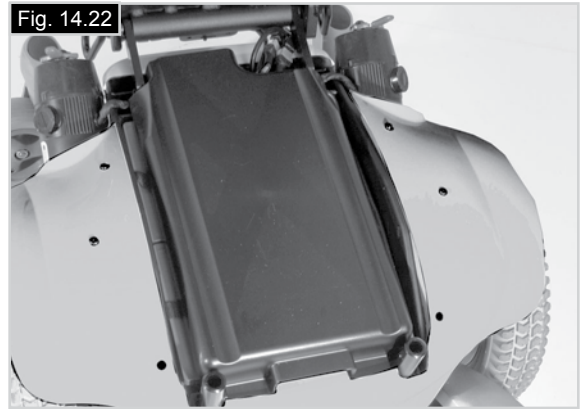

14.8 Controller access

For the Jive F/R please follow the “battery access instruction in section 12. This also gives access to the Motor Control Module (Fig. 14.27) on Jive F/R.

To access the controller on the Jive M take the rear shroud on the base between the rear castor wheels off. (Fig. 14.28).

For further information please contact your Sunrise Medical authorised dealer.



14.9 Storage

When storing your powerchair for long periods of time (in excess of one week) first fully charge, and then disconnect the batteries, to minimise battery discharge.

WARNING!

Never store your wheelchair in direct sunlight or in a damp/outdoor environment.

Direct sunlight might bleach plastic parts and cause metal parts to become hot.

14.10 Authorised Sunrise Medical service agents

The annual full service must be performed by an approved Sunrise Medical authorised dealer. For a list of approved authorised dealers in your area please contact Sunrise Medical Service Centre:

Sunrise Medical Limited
High Street Wollaston
West Midlands DY8 4PS
ENGLAND
Tel.: +44 (0) 1384446688
www.SunriseMedical.com

14.11 Recommended maintenance routines

Tools required:

Battery charger
Tyre pump
Cleaning cloth and dilute disinfectant
Wire brush
Petroleum jelly

WARNING!

If in any doubt about performing any maintenance on your wheelchair, contact your Sunrise Medical authorised dealer.

Daily checks:

With the control system switched off, check that the joystick is not bent or damaged and that it returns to the centre when you push and release it.

Visually inspect the wheelchair to make sure the legrests, armrests etc are correctly positioned and attached to the wheelchair and all fasteners are sufficiently tightened. Make sure that the backrest is correctly fitted and adjusted.

Ensure that the seat interface knobs are tight and secure. Make sure that all of the cushions are in place.

Weekly checks:

Parking brake:

This test should be carried out on a level floor with at least one metre clearance all around the chair.

Switch on the control system.

Check that the battery gauge remains on, or flashes slowly, after one second.

Push the joystick slowly forwards until you hear the parking brakes operate. The chair may start to move. Immediately release the joystick. You must be able to hear each parking brake operate, (click), within a few seconds.

Repeat the test a further 3 times, pushing the joystick slowly backwards, left and right.

Connectors:

Make sure that all connectors are securely mated.

Cables:

Check the condition of all cables and connectors for damage.

Joystick gaiter:

Check the thin rubber gaiter or boot around the base of the joystick shaft for damage or splitting. Check visually only, do not handle the gaiter.

Mounting:

Make sure that all components of the control system are securely mounted. Do not over-tighten any securing screws.



Please refer to Service manual for any information about Torques.

Switch on the hand control – Do the lights flash? This signifies that there is a fault in the electronic system. Refer to section 8 for basic troubleshooting. Operate all of the electric options, including lights and indicators (if fitted) to make sure that they work correctly. With the seating in an elevated position, drive the wheelchair to make sure that the 'creep' mode works which will slow the wheelchair. Drive the wheelchair in each of the drive profiles to make sure the wheelchair performs as it did before.

**WARNING!**

- If you are in any doubt about the performance requirements of your wheelchair contact your Sunrise Medical authorised dealer.
- After performing any maintenance or repairs on the wheelchair you must make sure that it is functioning correctly before it is used.
- A complete inspection, safety check and service should be made by a Sunrise Medical authorised dealer at least once per year.

Maintenance and Inspection Schedule	Daily	Weekly	Quarterly	Six month	Annually
Check battery level indicator and charge if necessary	*				
Check the joystick of the hand control is not bent or damaged	*				
Ensure all removable parts are securely locked in place	*				
Check lap strap for wear and make sure the buckle is operational	*				
Parking brake test		*			
Check tyres and inflate		*			
Ensure lights and indicators are operational and clean		*			
Ensure all cables and connectors are sound and are tidy and out of the way		*			
Clean wheelchair and upholstery		*			
Battery terminal inspection – Remove any corrosion and apply Petroleum jelly			*		
Apply general purpose grease to square runners to tilt and lift runners (if fitted)				*	
Check upholstery, seating, headrests, armpads and calfpads for wear				*	
WARNING! Complete inspection, safety check and service should be made by a Sunrise Medical authorised dealer					*

15.0 Specification sheets (EN 12184 & ISO 7176-15)



Sunrise Medical Limited
High Street Wollaston
West Midlands DY8 4PS
ENGLAND
Tel.: +44 (0) 1384446688
www.SunriseMedical.com

15.1 Model: Quickie Jive R

Fig.15.1



Maximum occupant mass (test dummy mass): 160 kg

The wheelchair Quickie Jive R conforms to the following standards:

a) requirements and test methods for static, impact and fatigue strengths (ISO 7176-8)

b) power and control systems for electric wheelchairs — requirements and test methods (ISO 7176-14)

c) climatic test in accordance with ISO 7176-9

d) requirements for resistance to ignition in accordance with ISO 7176-16

ISO 7176-15	Min	Max	Comments
Overall length (with legrest)	1185mm	1215 mm	With 50mm leg extensions fitted
Overall width	620 mm	660 mm	Without lights and with lights
Folded length	N/A	N/A	Not a folding chair
Folded height	N/A	N/A	Not a folding chair
Total mass (with batteries)	145 kg	187 kg	Min = Lightest chair with no seat module fitted. Max = Heaviest chair configuration
Mass of the heaviest part		23,5 kg	Heaviest removable part
Static stability downhill	0°	24°	0° tilt / 0° recline & max. seat height. Not with Balle unit
Static stability uphill	0°	10,7°	9° tilt / 12° recline & max. seat height. Not with Balle unit
Static stability sideways	0°	19,2°	0° tilt / 0° recline & max. seat height
Energy consumption (Max Range)		35km	Depending on terrain, speed and user weight
Dynamic stability uphill		10°	
Obstacle climbing		100 mm	100 kg (75 mm at 160 kg)
Maximum speed forward	6 km/h	13 km/h	
Minimum braking distance from max speed		3.1m	Dependant on programming
Seat plane angle	0°	9°	Not with Balle Tilt fitted
Effective seat depth	400 mm	560mm	
Effective seat width	400 mm	560 mm	
Seat surface height at front edge	430 mm	480 mm	With a 0° seat angle
Backrest angle	-5°	12°	mechanical
Backrest height	560mm	700mm	
Footrest to seat distance	340 mm	540 mm	
Leg to seat surface angle	0°	90°	
Armrest to seat distance	210mm	300mm	
Front location of armrest structure	260mm	560mm	
Handrim diameter	N/A	N/A	Not a manual chair
Horizontal location of axle	N/A	N/A	Not a manual chair
Minimum turning radius	1000 mm		Dependant on legrest option
Mass of the test dummy		160kg	
EN 12184			Comments
Maximum kerb height	50 mm	100 mm	
Ground clearance		75mm	
Turning space		1400 mm	
Reversing Width		12184mm	
Speed control operation force		1,5 N	
Direction control operation force		1,5 N	
Pressure switch range	-6,9 kPa	+6,9 kPa	Relative to atmospheric (-1.0 to +1.0 PSI)
Pressure switches operation force (puff)	N/A	N/A	Programmable
Pressure switches operation force (sip)	N/A	N/A	Programmable
Pressure resolution	0.1		
Pressure Barb size (OD)	0,15 Inches		

15.2 Model: Quickie Jive F

Fig.15.2



Maximum occupant mass (test dummy mass): 160 kg (240 kg FXL).

The wheelchair Quickie Jive F conforms to the following standards:

a) requirements and test methods for static, impact and fatigue strengths (ISO 7176-8)

b) power and control systems for electric wheelchairs — requirements and test methods (ISO 7176-14)

c) climatic test in accordance with ISO 7176-9

d) requirements for resistance to ignition in accordance with ISO 7176-16

ISO 7176-15	Min	Max	Comments
Overall length (with legrest)	1185mm	1215 mm	With 50mm leg extensions fitted
Overall width	620 mm	660 mm	Without lights and with lights
Folded length	N/A	N/A	Not a folding chair
Folded height	N/A	N/A	Not a folding chair
Total mass (with batteries)	145 kg	187 kg	Min = Lightest chair with no seat module fitted. Max = Heaviest chair configuration
Mass of the heaviest part		23,5 kg	Heaviest removable part
Static stability downhill	0°	15°	0° tilt / 0° recline & max. seat height. Not with Balle unit
Static stability uphill	0°	22,7°	9° tilt / 12° recline & max. seat height. Not with Balle unit
Static stability sideways	0°	16,4°	0° tilt / 0° recline & max. seat height
Energy consumption (Max Range)		35km	Depending on terrain, speed and user weight
Dynamic stability uphill		6°	
Obstacle climbing	75mm	100 mm	100 kg (75 mm at 160 kg)
Maximum speed forward	6 km/h	10 km/h	
Minimum braking distance from max speed	----	3.1m	Dependant on programming
Seat plane angle	0°	9°	Not with Balle Tilt fitted
Effective seat depth	400 mm	560mm	
Effective seat width	400 mm	560 mm	
Seat surface height at front edge	430 mm	480 mm	With a 0° seat angle
Backrest angle	-5°	12°	mechanical
Backrest height	560mm	700mm	
Footrest to seat distance	340 mm	540 mm	
Leg to seat surface angle	0°	90°	
Armrest to seat distance	210mm	300mm	
Front location of armrest structure	260mm	560mm	
Handrim diameter	N/A	N/A	Not a manual chair
Horizontal location of axle	N/A	N/A	Not a manual chair
Minimum turning radius	700 mm		Dependant on leg rest option
Mass of the test dummy		160kg	
EN 12184			Comments
Maximum kerb height		100 mm	
Ground clearance		75mm	
Turning space		1400 mm	
Reversing Width		12184mm	
Speed control operation force		1,5 N	
Direction control operation force		1,5 N	
Pressure switch range	-6,9 kPa	+6,9 kPa	Relative to atmospheric (-1.0 to +1.0 PSI)
Pressure switches operation force (puff)	N/A	N/A	Programmable
Pressure switches operation force (sip)	N/A	N/A	Programmable
Pressure resolution	0.1		
Pressure Barb size (OD)	0,15 inches		

15.3 Model: Quickie Jive M



Maximum occupant mass (test dummy mass): 160 kg

The wheelchair Quickie Jive M conforms to the following standards:

a) requirements and test methods for static, impact and fatigue strengths (ISO 7176-8)

b) power and control systems for electric wheelchairs — requirements and test methods (ISO 7176-14)

c) climatic test in accordance with ISO 7176-9

d) requirements for resistance to ignition in accordance with ISO 7176-16

ISO 7176-15	Min	Max	Comments
Overall length (with legrest)	1070 mm	1130 mm	With 50mm leg extensions fitted
Overall width	622 mm	660 mm	Without lights and with lights
Folded length	N/A	N/A	Not a folding chair
Folded height	N/A	N/A	Not a folding chair
Total mass (with batteries)	115 kg	180 kg	Min = Lightest chair with no seat module fitted. Max = Heaviest chair configuration
Mass of the heaviest part		23,5 kg	Heaviest removable part
Static stability downhill	8°	25°	0° tilt / 0° recline & max. seat height. Not with Balle unit
Static stability uphill	19°	25°	9° tilt / 12° recline & max. seat height. Not with Balle unit
Static stability sideways	14°	21°	0° tilt / 0° recline & max. seat height
Energy consumption (Max Range)		35 km	Depending on terrain, speed and user weight
Dynamic stability uphill		10°	
Obstacle climbing		100 mm	100 kg (75 mm at 160 kg)
Maximum speed forward	6 km/h	13 km/h	
Minimum braking distance from max speed		3.1m	Dependant on programming
Seat plane angle	0°	9°	Not with Balle Tilt fitted
Effective seat depth	400 mm	560mm	
Effective seat width	400 mm	560 mm	
Seat surface height at front edge	430 mm	480 mm	With a 0° seat angle
Backrest angle	-5°	12°	mechanical
Backrest height	560mm	700mm	Depends on option chosen and length of back posts
Footrest to seat distance	340 mm	540 mm	
Leg to seat surface angle	0°	90°	
Armrest to seat distance	210mm	300mm	Using Standard Cushion
Front location of armrest structure	260mm	560mm	
Handrim diameter	N/A	N/A	Not a manual chair
Horizontal location of axle	N/A	N/A	Not a manual chair
Minimum turning radius	560 mm	630 mm	Dependant on legrest option
Mass of the test dummy		160kg	
EN 12184	MIN	MAX	Comments
Maximum kerb height		100mm	
Ground clearance		90 mm	
Turning space		1100 mm	
Reversing width		12184mm	
Speed control operation force		1,5 N	
Direction control operation force		1,5 N	
Pressure switch range	-6,9 kPa	+6,9 kPa	Relative to atmospheric (-1.0 to +1.0 PSI)
Pressure switches operation force (puff)	N/A	N/A	Programmable
Pressure switches operation force (sip)	N/A	N/A	Programmable
Pressure resolution	0.1		
Pressure Barb size (OD)	0,15 Inches		

16.0 Service History

This section is designed to assist you in keeping a record of any service and repairs to your wheelchair. Should you decide to sell or exchange your vehicle in the future, this will prove most helpful to you. Your Service Agent will also benefit from a documented record and this manual should accompany the wheelchair when service or repair work is carried out. The Service Agent will complete this section and return the manual to you. All our scooters, wheelchairs and power chairs undergo rigorous tests to ensure that they meet our requirements of comfort, safety and durability.

Our success is based on the strong traditions of quality, value for money and genuinely caring for our customers. We pride ourselves not only on designing and building the most innovative products but also on our commitment to offer an excellent standard of customer service both during and after sale.

17.0 Disposal

The symbols below mean that in accordance with local laws and regulations your product should be disposed of separately from household waste. When this product reaches the end of its life, take it to the local collection point designated by local authorities. The separate collection and recycling of your product at the time of disposal will help conserve natural resources and ensure that it is recycled in a manner that protects the environment.

Ensure you are the legal owner of the product prior to arranging for the product disposal in accordance with the above recommendations and national requirements.

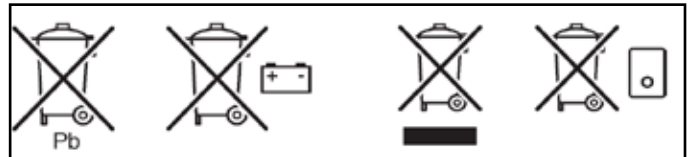

Model					Serial No				
Year	1	2	3	4	Year	1	2	3	4
Date					Date				
Controller					Chassis				
On/Off switch					Condition				
Output plug					Steering				
Joystick					Upholstery				
Brakes					Seat				
Programmable configuration					Backrest				
Batteries					Armrests				
Level					Electrics				
Connections					Condition of loom				
Discharge level					Connections				
Wheels					Test run				
Wear					Forwards				
Pressure					Reverse				
Bearings					Emergency stop				
Wheel nuts					Left turn				
Motors					Right turn				
Wiring					Up/Down slope				
Connections					Over obstacles				
Noise					Parking brake				
Brakes									
Brushes					NOTE: Only use Sunrise Medical parts for service and repairs				

Dealer signature and stamp:

Dealer signature and stamp:



Sunrise Medical GmbH & Co.KG
Kahlbachring 2-4
D-69254 Malsch/Heidelberg
Germany
Tel.: +49 (0) 7253/980-555
Fax: +49 (0) 7253/980-111
www.SunriseMedical.com

Sunrise Medical
Thorns Road
Brierley Hill
West Midlands
DY5 2LD
Phone: 0845 605 66 88
Fax: 0845 605 66 89
www.SunriseMedical.com

Sunrise Medical S.L.
Polígono Bakiola, 41
48498 Arrankudiaga – Vizcaya
España
Tel.: +34 (0) 902142434
Fax: +34 (0) 946481575
www.SunriseMedical.es

ZAC de la Vrillonnerie
17 Rue Michael Faraday
37170 Chambray-Lès-Tours
France
Tel : 02 47 55 44 00
Fax : 02 47 55 44 03
www.SunriseMedical.fr

Sunrise Medical S.r.l.
Via Riva, 20 – Montale
29122 Piacenza – Italia
Tel. 0039 0523 573111
Fax 0039 0523 570060
e-mail info@sunrisemedical.it
website www.SunriseMedical.com

Sunrise Medical AG
Lückhalde 14
3074 Muri/Bern
Schweiz/Suisse/Svizzera
Fon +41 (0)31 958 3838
Fax +41 (0)31 958 3848
www.SunriseMedical.com

Sunrise Medical AS
Dynamitveien 14 b
1400 Ski
Norway
Tel.: +47 (0) 66963800
Faks: +47 (0) 66963880
www.SunriseMedical.no

Sunrise Medical AB
Box 9232
400 95 Göteborg
Sweden
Tel: +46 (0)31 748 37 00
Fax: +46 (0)31 748 37 37
www.SunriseMedical.com

Sunrise Medical B.V.
Groningenhaven 18-20
3433 PE Nieuwegein
Nederlands
Tel.: +31 (0) 30-60-82 100
Fax: +31 (0) 30-60-55 880
www.SunriseMedical.com

G2 A/S
Graham Bells Vej 21-23 A
8200 Arhus N
Denmark
Tel.: +45 87 41 31 00
Fax: +45 87 41 31 31
www.G2.dk

Sunrise Medical Pty. Ltd.
6 Healey Circuit, Huntingwood,
NSW 2148,
Australia
Phone: 9678 6600,
Orders Fax: 9678 6655,
Admin Fax: 9831 2244.
Australia
www.SunriseMedical.com