

ROMA MEDICAL



Corella

S741 USER MANUAL

Please ensure that this manual is read and understood before using the scooter.

Contents	Page
Introduction	3
Intended Use	3
Technical Specification	3
Feature Guide	4
Safety Advice	5
Adjustments	
• Tiller angle	6
• Tiller Lock	6
• Folding the tiller (for transportation)	6
• Seat removal	7
• Seat height	7
• Seat Swivel	7
• Arm width adjustment	7
Tiller Controls	8
Brake Release / Freewheel Operation	9
Starting to Drive	
• Getting Started	10
• Moving Off	10
• Steering	10
• Reversing	10
• Ramps / Slopes	10
• Surfaces	11
• Transferring	11
Transport and Storage	11
Batteries and Battery Charger	12
Maintenance	13
Troubleshooting	
• Circuit Breaker	14
• Fuses	14
• Check List	15
Further Information	16
Warranty	

Introduction

Congratulations on your purchase of the ROMA **Corella** scooter. This scooter incorporates the latest innovative designs. The ROMA **Corella** can be used in confined spaces both indoors and out. A direct drive rear transaxle and electromagnetic brake give a safe and efficient ride. The scooter can be easily disassembled without tools and will fit into the boot of most vehicles for easy transport. The detachable battery pack allows convenient charging wherever necessary.

Intended Use

The ROMA **Corella** is carefully designed for indoor or outdoor use in pedestrian areas by a single individual with limited mobility up to a maximum weight of 114kg (18st). The acute manoeuvrability prohibits the use by persons who are severely physically impaired or those who have balance difficulties. Your assessor/healthcare professional will determine the suitability of the scooter for each individual's intended use.

Note: Persons with lower body amputations should not use this device unless evaluated with artificial limbs fitted, as stability may be compromised due to an irregular centre of gravity.

Technical Specification

Class 1 Medical Device

Class 2 Indoor/Outdoor Vehicle

Overall Size		Seat Dimensions	
Length	975mm / 38.5"	Width	460mm / 18"
Width	580mm / 23"	Depth	410mm / 16"
Height	900mm / 35.5"	Seat to floor pan	360mm / 14" 410mm / 16"
Battery	2 x 12Ah	Backrest height	360mm / 14"
Height (Folded)	710mm / 28"	Range	12km / 8m*
Maximum user weight	114kg / 18st	Seat to floor	470mm / 18.5" 520mm / 20.5"
Safe working slope	6°	Battery charger (off board)	1.8 Amp
Weight with batteries	46kg	Battery Pack Weight	10kg
Max. Speed	6km/h / 4mph		

*Passenger weight, rough ground conditions, low temperatures and battery condition can affect maximum range.

Component Weights:-

Front Chassis	15kg
Rear Chassis	11kg
Seat	10kg
Battery Pack	10kg

'Corella'



- 1. Tiller control head**
- 2. Detachable swivel padded seat with fold down back**
- 3. Detachable basket**
- 4. Detachable battery pack**
- 5. Tiller angle adjustment knob**
- 6. Front lift handle**
- 7. Anti-tip wheels**
- 8. Puncture proof non-marking wheels**

Safety Advice



DO:

- Read this manual carefully before using your scooter.
- Turn the power off when transferring to and from the scooter.
- Select a slow speed when going down gradients (max 6°) or over uneven ground.
- Keep your feet on the scooter whilst driving.
- Ensure the seat is in a fixed position facing forwards before driving.
- Ensure the tiller is secure.
- Ensure the batteries are fully charged before your journey.
- Avoid rough or soft terrain and long grass wherever possible.
- Be aware of other road users and pedestrians.
- Turn the power off when not in use.
- Follow the maintenance guide to ensure safe operation of the scooter.
- Always remove the keys if leaving the scooter unattended. Unauthorised persons/children may use the scooter resulting in injury.



DO NOT:

- Carry passengers.
- Exceed inclines over 6°.
- Traverse inclines.
- Attempt inclines if the surface is slippery.
- Turn sharply at full speed.
- Exit or enter the scooter unless the power is switched off.
- Switch off the power whilst driving – this will cause the scooter to stop abruptly (see emergency procedures – page 16).
- Use the scooter where you cannot safely or legally walk.
- Attempt to climb or descend kerbs except drop down kerbs.
- Use the scooter if under the influence of alcohol or any medication.
- Use a mobile phone whilst driving.
- Attempt to negotiate steps or escalators.
- Sit on the scooter if being transported in a vehicle.
- Attempt to tow any other devices.
- Exceed the stated weight limit.
- Connect any other devices to the batteries as this could cause permanent damage and void your warranty.
- Use any other batteries/charger other than those supplied by ROMA.
- Travel through water or over soft terrain (mud, sand etc.) Avoid cobbles.
- Travel on the road except when crossing between pavements.
- Lift the scooter by the shroud assembly or any plastic part.
- Sharply shift your centre of gravity as this could make the scooter unstable.

Every care has been taken to ensure that your scooter will give you safe, reliable service provided you adhere to the advice given above.

Adjustments

Tiller Angle Adjustment

At the base of the tiller is a handknob. Rotate the handknob anti-clockwise to open the joint (DO NOT FULLY UNDO THE HANDKNOB). Select the desired tiller angle and re-tighten the handknob. Ensure the tiller is fully secure before using the scooter.

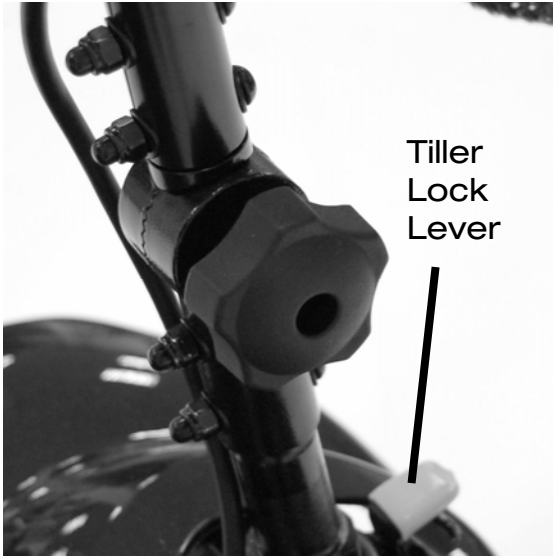

Tiller Lock Lever

The tiller lock lever locks the front wheels in the forward position for transport purposes.

For horizontally placed levers, the lock lever should be pushed down to lock and lifted to release.

For the vertical type, the lever should be pulled forward to lock and pushed toward the tiller to release.

CAUTION: Never attempt to drive the scooter with the tiller locked. If the steering is unresponsive immediately stop the scooter and check that the tiller has not been accidentally locked.

Folding the Tiller Assembly (For transport purposes)

Release the adjustment mechanism as above and fold the tiller down fully until it reaches the position shown below and re-tighten the handknob to secure the tiller in this position. The battery can also be easily lifted out of the chassis for transportation.

Do not carry the scooter by the tiller stem in the area indicated below.

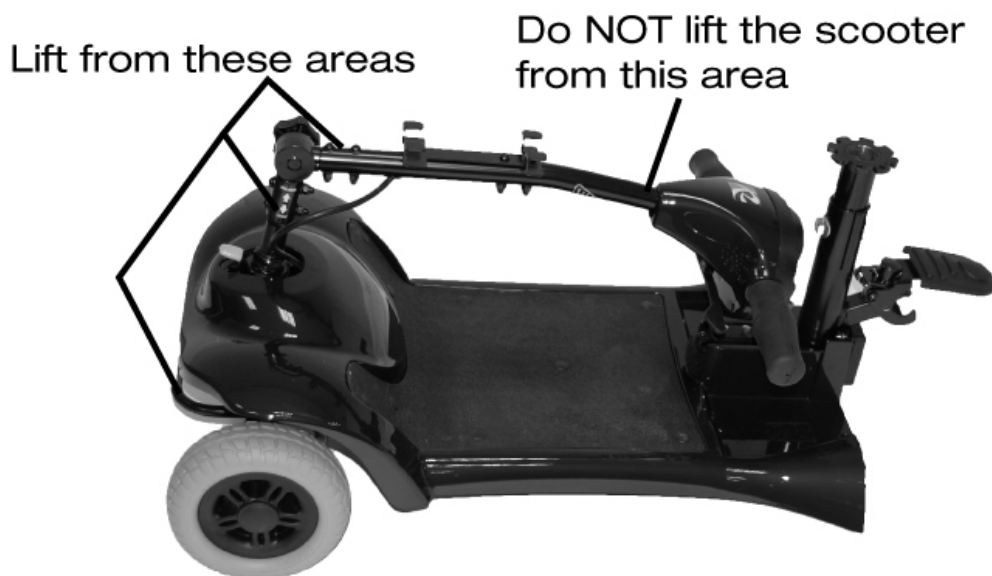

Continued.....

Seat Removal

To remove the seat, fold down the back of the seat and simply lift the seat away from the chassis.

Do not hang baggage or other objects on the back of the seat as this may affect stability.

Seat Height Adjustment

Remove the seat as previously described. Undo the stem fixing bolt using 17mm spanners and adjust the stem to the desired height. Re-fit the bolt and tighten. Re-fit the seat as above.

The higher the seat is adjusted; stability may be affected due to the higher centre of gravity.

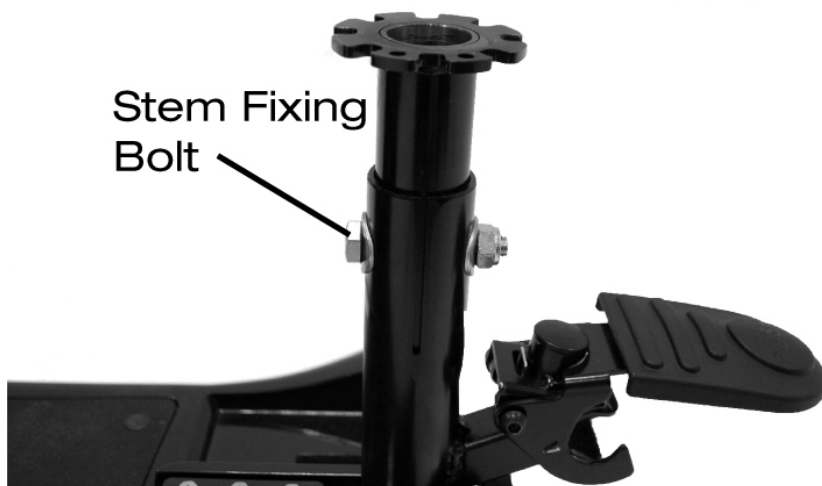

Seat Swivel

The seat has a lockable swivel base to allow easier transfers. Simply lift the lever and rotate the seat at the same time. Releasing the lever will allow the seat to lock in position. The seat locks in 45 degree intervals. Always ensure the seat is in a locked position before mounting or dismounting the scooter. The seat should always be locked forward whilst driving.



Arm Adjustments

On each side of the seat towards the back there are two hand knobs, these are to adjust the width of the armrests or to remove them for transport.

Turn the knobs anti-clockwise to loosen. Once the knobs are loose you will be able to adjust the armrests in or out to the desired width. Re-tighten when a comfortable width has been achieved or remove the armrests completely for transport.

If removing the armrests for transport, ensure that the knobs are re-tightened to avoid them rattling loose and falling out.

Do not apply full body weight to the armrests for transferring. Lift the arm up out of the way to transfer to another seat.

Tiller Controls

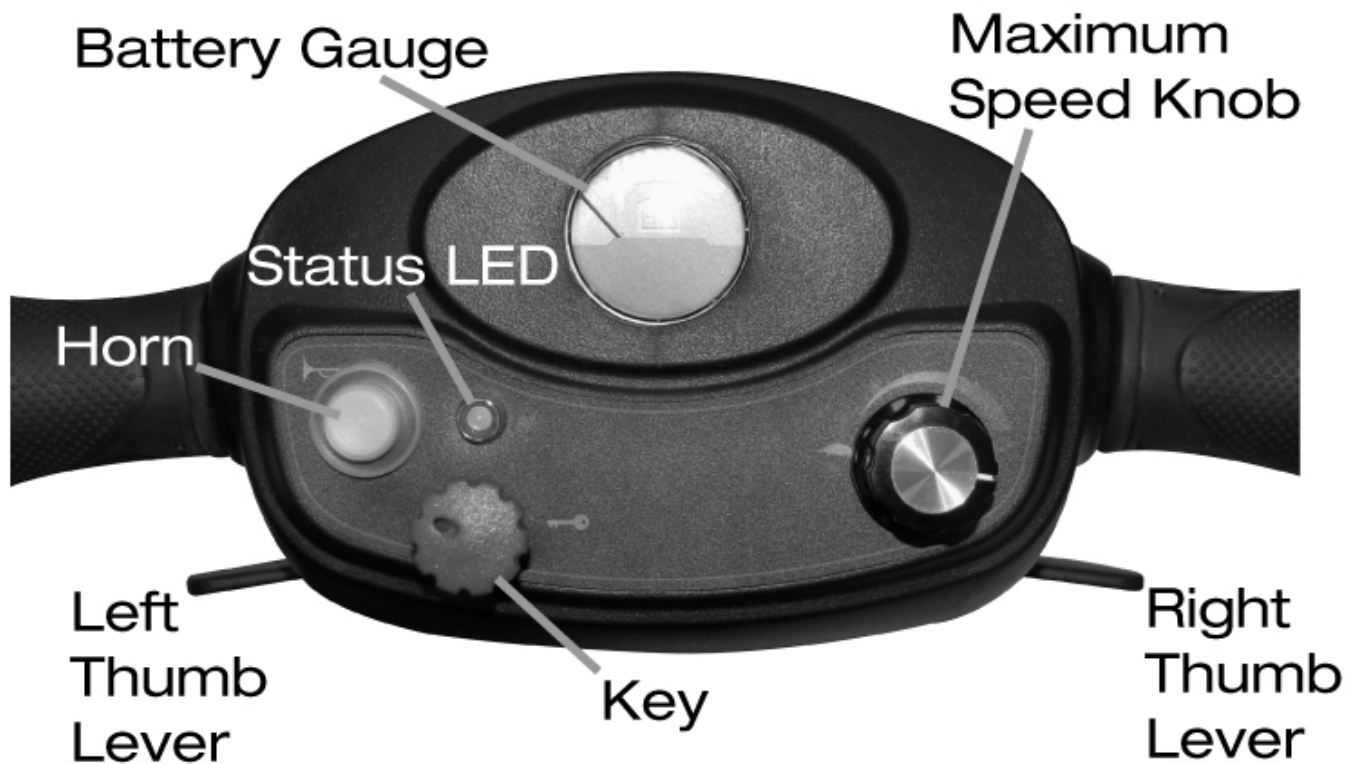

Thumb Lever Controls

The thumb levers control the reverse and forward motion of the scooter. Pushing the right lever will drive the scooter forward, pushing the left lever will reverse the scooter. The amount of pressure applied to the levers will determine the speed the scooter travels up to the maximum speed selected. More pressure = more speed. Release the thumb lever and the scooter will automatically come to a safe stop as the electromagnetic brake is applied.

Horn Button

The yellow button operates the scooters horn. ***This should only be used to warn others of your presence and not as a rebuke of any form.***

Battery Level Indicator Gauge

This gauge gives you a guide to the amount of charge left in the scooters batteries. This will give the truest reading when the scooter is in motion. ***Always fully charge the batteries before driving your scooter and never let the batteries become completely drained, as this may cause permanent damage to the batteries.***

On/Off Key

Insert the key plug supplied with the scooter. The battery gauge needle will move. There may be a slight delay before the thumb levers operate as the controller checks the scooters circuits. ***Never leave the key in the switch unattended to prevent unauthorised use. Do not switch the power off to stop the scooter unless it is an emergency. The scooter will stop very abruptly if stopped in this way.***

Continued.....

Speed Control Dial

The speed control enables you to set the maximum speed of the scooter. Turn clockwise to increase the maximum speed and anti-clockwise to decrease. **Always start at a slow speed until accustomed with the characteristics of your scooter. Do not put excessive pressure on the dial. Only turn as far as the stops.**

When driving in pedestrian areas such as shopping precincts and busy pavement areas always respect other pedestrians and turn the maximum speed down so that the scooter travels at the walking pace of others around you.

Brake Release / Freewheel Operation

The brake release lever is situated at the right rear of the scooter. This lever allows you to disengage the drive mechanism and push the scooter in 'freewheel' mode. To disengage the drive, pull the lever upward to the 'disengaged' position. The scooter can now be pushed.

Simply push the lever back down to re-engage the drive mechanism (the scooter can now be driven). The scooter will not operate when the lever is in the disengaged position. The scooter must be turned off and on by the key switch to reset the circuits before it will resume normal operation. The status led will flash continually if the brake is disengaged when it is switched on.

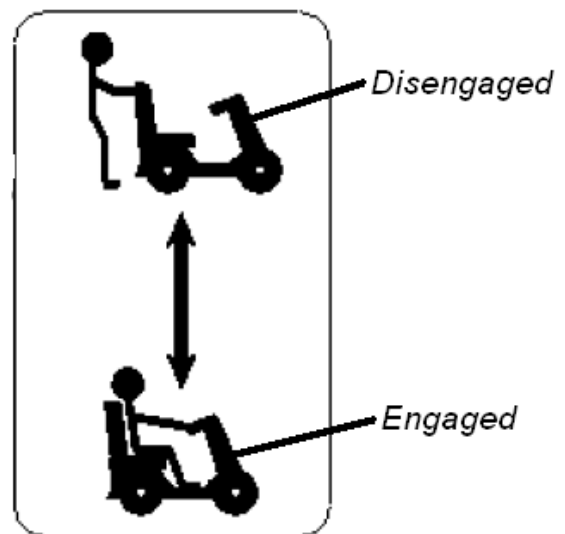

Caution! Never leave the scooter unattended whilst in freewheel mode as it will roll away down an incline. 'Freewheel' mode should only be used in an emergency to move the scooter due to power failure. NEVER move the scooter in this mode whilst it is occupied.

When in freewheel mode the scooter may be pushed on level ground at a walking pace. The scooter will 'auto-brake' if this speed is exceeded.

Starting to Drive

Getting Started

✓ **Note:** You must fully charge the batteries prior to first use (see 'Batteries and Charging')

Select an area with plenty of space.

Mount the scooter by lifting the arm and sliding onto the seat. **Ensure the seat is securely locked in the forward facing position before driving.** Adjust the tiller and seat if necessary (see 'Adjustments'). **DO NOT use the tiller to fully support you during transfers.**

Moving Off

Push the key fully into the tiller head to turn on the power.

Initially set the speed control to a low setting. Push your right thumb lever and the scooter will move forward slowly. The further you push the lever the faster the scooter will travel, but only to the maximum speed that has been selected. Release the lever and the scooter will come to a smooth controlled stop.

⚠ **Caution! DO NOT switch off the power to stop the scooter as this will cause the transmission to lock and the scooter will come to a sharp stop, which could possibly cause injury. This procedure should only be used in an emergency.**

Steering

Steering the scooter is light and easy. Ensure you give obstacles a wide clearance to avoid the rear wheels catching. When steering through limited spaces, turn the tiller in the direction that you wish to go and apply power gently. The scooter can turn very tightly with complete stability at slow speeds.

⚠ **Caution! NEVER turn sharply at high speeds as it can make the scooter unstable. The maximum speed should be set at 50%.**

Reversing

Before reversing ensure the area behind the scooter is free from any obstacles or hazards. Adjust the speed setting to low before you reverse. Push the left thumb lever, and steer wide of all corners and obstacles.

⚠ **Caution! Do not reverse onto a main thoroughfare.**

Ramps / Slopes

The stability of your scooter depends on several factors such as seat height, angle of gradient and the users height and weight. When approaching an incline, do so directly and not at an angle and avoid making turns where possible.

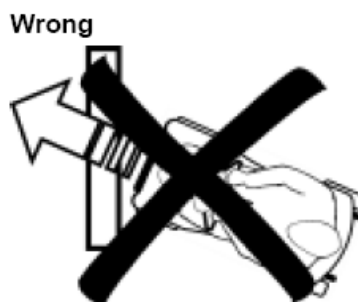
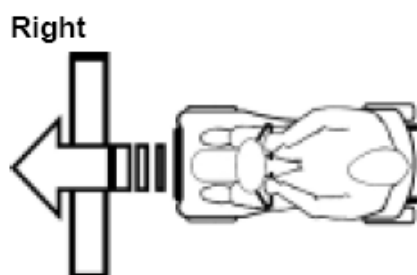

Continued.....

Surfaces

Your scooter will perform well over many surfaces. However, avoid long grass, loose gravel, sand, mud and ice.

Transferring

Lift up the armpad from the side you wish to leave or sit on the scooter. Use an aid for balance if required. DO NOT use the tiller or armrests to support the full weight during transfers.

Transport and Storage

The ROMA **Corella** is designed to be quickly and easily disassembled without tools into sections for transportation and storage:

Guidelines for Disassembly

Follow the following for the easy disassembly of your scooter:

(Ensure the scooter is switched off before disassembling)

1. Lift the basket up and off the bracket.
2. Remove the seat as described earlier.
3. Remove the battery pack by lifting the handle.
4. Loosen the tiller adjustment knob and lower the tiller and re-tighten the knob. **Do not carry the chassis by the tiller stem as shown previously.**
5. Depress the release paddle and separate the front chassis assembly by lifting it away from the rear part.

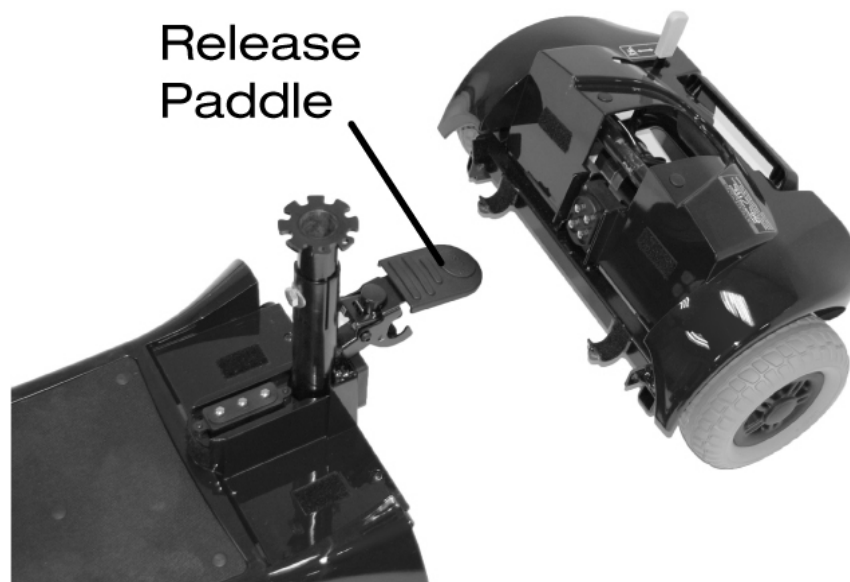

Assembly is the reverse of the above procedure.

The ROMA **Corella** is now separated into four components for easy transportation or storage.

If the scooter is not to be used for periods of more than a few weeks, fully charge the batteries but leave the battery pack disconnected from the scooter.

Batteries and Battery Chargers

Batteries

Charge the batteries completely (8-12 hours) prior to first use.

The ROMA **Corella** is supplied with a closed battery pack which contains two 12Amp, 12 Volt sealed lead acid batteries. The battery pack is situated under the front of the seat and can be removed by lifting it away from the chassis.

Low temperatures, rough terrain and the weight of the user can affect battery performance. Your battery gauge is a guide only to the level of charge remaining in your batteries and will give its best indication while the scooter is moving.

Note: Batteries recommended by ROMA MUST be used if they need to be replaced. An authorised ROMA dealer must carry out battery replacement.

Battery Charger

The battery charger is a 1.8-amp switch type off board. The battery charging port is located on the battery pack. This special feature allows the batteries to be charged independently of the main scooter.

Before using your scooter for the first time be sure to fully charge the batteries, this may take up to 12 hours.

To charge the batteries connect the 3-pin male charger plug into the charging socket on the battery pack. Plug the 3-pin mains plug into a wall socket and switch on. A constant red light will show when the battery charger is connected and charging is underway (this will flash if there is a break in the connection). The red light indicates that the batteries are receiving charge, this will change to solid green when the charging cycle is complete. Always turn off mains power to the charger before disconnecting the plug from the battery box.



Caution! Do not charge the batteries for longer than 12 hours. Always charge the batteries in a well-ventilated indoor area. You must still maintain charging the batteries even if the scooter is not to be used for a prolonged period of time (2 to 3 weeks). Failure to do so could result in permanent damage and render the batteries unusable. Wherever possible do not interrupt the charge cycle until the batteries are fully charged. Continual interruption can permanently damage the batteries. If the charging lead should get damaged discontinue use immediately and seek a replacement from your dealer. ONLY USE THE CHARGER SUPPLIED WITH YOUR SCOOTER. Do not leave the charger plugged into to the charger port after the charge is complete. ALWAYS remove the keys from the scooter when charging.



Disposing and recycling of used batteries

Batteries must always be recycled correctly. Do not dispose of them with your domestic refuse.



For further information regarding your nearest recycling facility please contact your local authority.

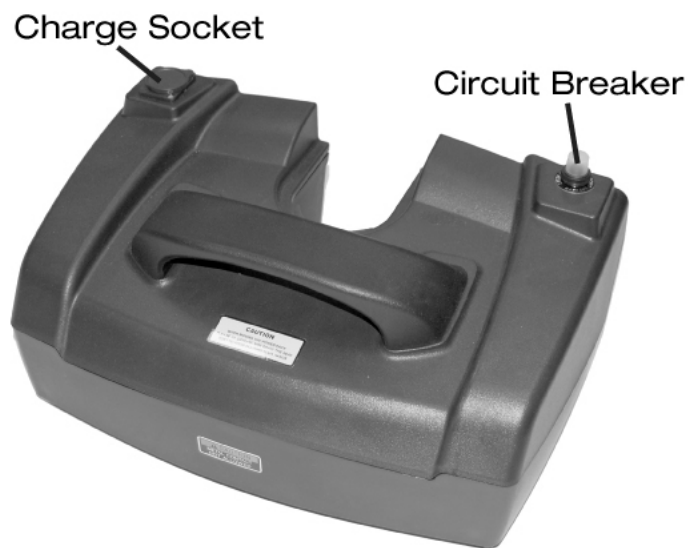

Maintenance

Product Life Expectancy

Your scooter has been designed to provide the user with a long, reliable life provided it is correctly maintained and regularly serviced by an authorised dealer. However, due to inevitable wear and tear and technological improvements it is recommended that the average useable life of this scooter is five years.

General Cleaning

The shrouds and seat of the scooter should be cleaned using a damp cloth and gentle detergent. Do not use abrasive cleaners or solvents, as this will damage the plastic components. Do not spray water (*hose or pressure washer*) onto the scooter as this may cause damage to the electronics.

Routine Maintenance

We suggest that your scooter should undergo a full service at least once a year by an authorised ROMA dealer.

Please check the following on a weekly basis:

- Tyres are in good condition
- Wheels spin freely
- Moving parts, pivots and frame fixings are not damaged or worn
- All hand knobs and levers are secure

Contact Cleaning

Your scooter has contact plate and pin connectors which will need to periodically cleaned to maintain their performance.

NEVER use abrasive material such as sandpaper to clean the plates or pins as this will enable dirt to build up and cause connection problems. Use a soft cloth and an alcohol based cleaner to remover any dust / dirt from the connections and if necessary use an electical contact treatment grease to lightly cover the plate connections.

The areas to be cleaned are shown in the following images.

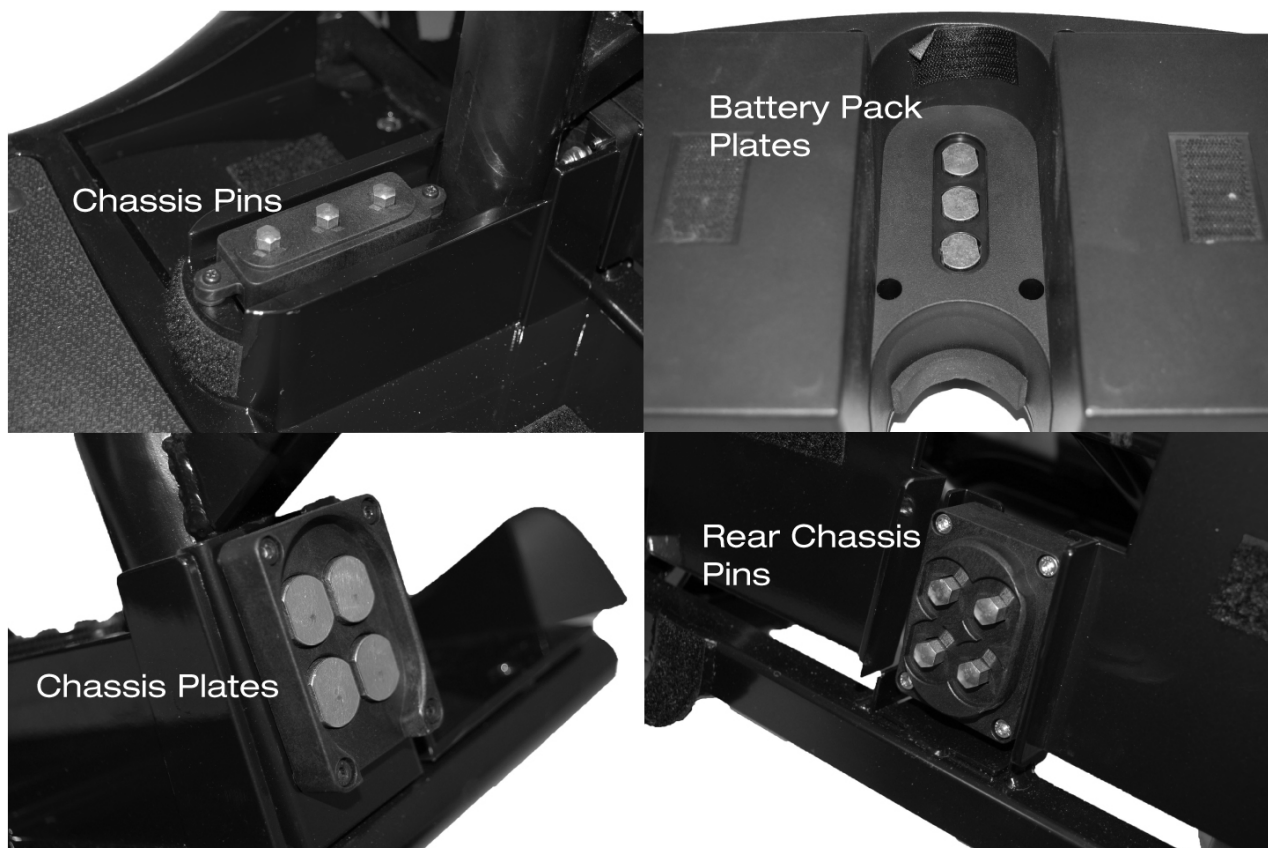

Troubleshooting

Circuit Breaker

Your scooter is fitted with the latest in electronic controls that are programmed to protect the electrical system from abnormal overloads. Fitted for extra protection is a circuit breaker, which is located on the battery pack. Should there be a situation where your scooter stops for no apparent reason please check that the circuit breaker has not tripped. Simply press the button to reset the circuit breaker.

✓ **Note: Should the circuit breaker continue to trip turn off the scooter immediately and consult your dealer.**

Fuses

There are two 40 amp blade type fuses inside the battery pack to give protection against possible overload on the wiring.

⚠ **Caution! Do not attempt to open the battery pack to replace the fuses. Please take the battery pack to an authorised ROMA dealer to replace any blown fuses.**

Continued.....

Check List

If your scooter fails to operate, please check the following:

- The unit is switched on.
- All plugs and connections are firmly fixed.
- Battery level shows full charge.
- Freewheeling device is in the drive position.
- Circuit breaker has not tripped.

If the freewheel device has been operated with the scooter switched on, the scooter will not operate until the key switch has been turned off and on again.

Should a fault occur, the status led on the tiller head will indicate a flash sequence which relates to the fault in the table below.

Flash Code	Description	Scooter Condition	Action
1	Charge Batteries	Scooter Runs	Batteries less than 23.3v. Charge as soon as possible.
2	Battery voltage too low	Scooter will not run	Batteries less than 16.5v. Charge immediately.
3	Battery voltage too high	Scooter will not run	Possible excessive re-gen charging by travelling downhill for long periods. Turn power off / on to reset controller.
4	Current time limit out	Scooter will not run	Excessive current draw over long periods. Turn off scooter and leave for a few minutes before restarting.
5	Brake fault	Scooter will not run	Check scooter is not in freewheel. Possible faulty brake.
6	Thumb lever displacement	Scooter will not run	Check thumb lever is centred. Faulty potentiometer.
7	Speed pot error	Scooter will not run	Action as above and check loom for damage / short circuit.
8	Motor error	Scooter will not run	Open motor circuit. Check motor brushes and connections for contact or short circuits.
9	Controller error	Scooter will not run	Possible controller fault. Refer to dealer.



Note: Should your scooter fail to operate after checking these possible problems, consult your local ROMA dealer immediately.

Further Information



Safety Information Regarding Electromagnetic Interference (EMI)

Scooters and powerchairs are designed to operate under certain conditions. However, radio waves or electromagnetic fields may affect the operation of the scooter. The source of EMI could be radio or television transmitters or portable devices such as mobile phones, portable CB radios etc.

Should any unintentional movement occur turn the scooter off as soon as safely possible.

Solar Energy

During periods of sunny weather, it is possible that surfaces of your scooter may reach high temperatures (as with motor vehicles). Please take precautions if leaving the scooter in direct sunlight for any period of time. Seek shade or cover the seat and hand controls to keep any temperature increases to a minimum.

Health Factors

Suitability for this product has been assessed on the user's current state of health. It is essential that the user regularly monitor their ability to use the scooter safely.

General Use

Take heed of the information given in this manual regarding safety and the maintenance of your scooter. If adhered to, your scooter should give you years of reliable mobility.

Storage and General Care

We recommend that the scooter is always stored in a dry environment such as a garage or shed to protect the chassis and other components from corrosion. Do not leave the scooter outside during rainstorms. If the scooter is wet, wipe with a dry cloth to ensure there is no ingress of water into the internal components of the scooter.

During everyday use, do not use in rain showers or travel through puddles. Avoid use in areas where the scooter could become contaminated with sand or abrasive materials.

Emergency Procedures

Should your scooter behave erratically or become unresponsive whilst driving, release the wig-wag lever so it may return to its neutral position and switch off the power at the key / switch. These procedures will stop the scooter and activate the braking system, preventing any further uncontrolled manoeuvres.

Note: Switching the power off at the key / switch can cause the scooter to stop abruptly and should only be used to stop the scooter during an emergency as this can damage the drive unit.

Continued.....

Product Stability

Scooters and powered wheelchairs are designed to allow the user flexibility of movement in restricted areas. Driving at maximum speed and attempting sharp turns can create a situation where the product becomes unstable. Therefore it is essential that the user pay attention to the guidance set out in this manual.

For maximum stability the speed setting should be set up to 50% of the maximum available (halfway between the tortoise and the hare or just entering the red sector on the speed indicator depending on the model.)

The main factors affecting stability are:

- Maximum speed setting
- Seat height
- User movement
- User's manoeuvres
- Gradients or slopes

Please keep your speed to a level where you can safely stop without having to make any erratic turns.

Do not load bags etc. on the back of the seat as this will affect the centre of gravity and could increase instability.

Do not lean outside of the 'footprint' of the product, especially whilst moving.

Avoid making turns on gradients or slopes.

Driving in Pedestrian Areas

As mentioned previously, when using the scooter in pedestrian areas always lower your maximum speed to that of the pedestrians around you. Remember the stopping distance of your scooter and always allow enough space to stop safely to avoid collisions with pedestrians or other objects.

Warranty Terms and Conditions

This is to certify that your Roma Medical product is warranted for a period of 12 months from the date of original purchase. This warranty is not transferable.

The main frame has a limited lifetime warranty from manufacturing defects.

Should a defect or operating fault arise within this period the Dealer from where the product was originally purchased should be notified immediately. Failure to register the fault may invalidate the warranty. The Dealer from where the product was purchased is responsible for any warranty repairs.

Roma Medical warrants that if a fault occurs within this period due to faulty workmanship or materials that the product will be repaired (or replaced at the Companys discretion) free of charge.

Any unauthorised modifications will invalidate the warranty.

Parts which are subjected to normal wear and tear, accidental damage, neglect or misuse are excluded from this warranty. Normal wear and tear includes tyres, chassis covers, bulbs, seat coverings etc.

Component parts replaced outside this period carry a six-month warranty. (Standard terms and conditions apply for this period).

Model:

Serial No:

Purchase Date:

Dealer Stamp

Roma Medical Aids Ltd
York Road, Bridgend Industrial Estate,
Bridgend
CF31 3TB
Tel: 01656 674488 Fax: 01656 674499
Email: sales@romamedical.co.uk
www.romamedical.co.uk

Roma Medical reserve the right to change specifications without prior notice

