



ASSEMBLY



OPERATION



COMFORT



MAINTENANCE

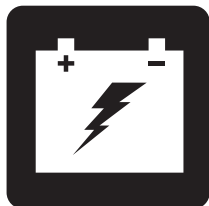

BATTERY
CHARGING



TRAVEL SCOOTER SERIES

OWNER'S MANUAL

TRAVEL SCOOTER FEATURES TABLE

Model 	Console Style				Battery Pack Style			Battery Charging		Frame Lock-up Style		Options *		
	A	B	C	D	A	B	C	On Unit	Off Unit	A (Release Lever)	B (Lock-up Pin)	Suspension Seat Post	Lights	Changeable Color Panels
36	•					•		•	•		•			
40X	•				•			•	•	•				
44X	•				•			•	•	•				
40E		•	•AU only		•			•	•	•				•
44E		•	•AU only		•			•	•	•				•
40LX				•	•			•	•	•		•	•	•
44LX				•	•			•	•	•		•	•	•
50LX				•	•			•	•	•			•	•
54LX				•	•			•	•	•			•	•
53			•		•			•	•	•				•
53HD			•		•			•	•	•				•
54			•		•			•	•	•		•		•
54HD			•		•			•	•	•				•
73				•	•			•	•	•		•	•	•
74				•	•			•	•	•		•	•	•
83		•					•	•			•			
84		•					•	•			•			

***NOTE:** Travel Scooter options vary by country. Please contact your Provider to determine which options are available for your Travel Scooter.

NOTE: Please become familiar with your Travel scooter's model number. The number can be found on the product specification sheet in your owner's package. Throughout this owner's manual, Travel Scooter attributes are identified by model number (far left-hand column on Travel Scooter Features Table). Knowing your unit's model number will aid you in determining your particular Travel Scooter's unique characteristics.

INTENDED USE

The intended use of the Travel Scooter device is to provide mobility to persons limited to a seated position that have the capability of operating a scooter.

NOTE: This owner's manual is compiled from the latest specifications and product information available at the time of publication. We reserve the right to make changes as they become necessary. Any changes to our products may cause slight variations between the illustrations and explanations in this manual and the product you have purchased. The latest/current version of this manual is available on our website.

NOTE: This product is compliant with WEEE, RoHS, and REACH directives and requirements.

NOTE: The Travel Scooter and its components are not made with natural rubber latex. Consult with the manufacturer regarding any after-market accessories.



CONTENTS

SAFETY GUIDELINES	3
I. SAFETY	4
II. YOUR TRAVEL SCOOTER	6
III. BATTERIES AND CHARGING	13
IV. OPERATION	19
V. COMFORT ADJUSTMENTS	21
VI. DISASSEMBLY AND ASSEMBLY	24
VII. BASIC TROUBLESHOOTING	26
VIII. CARE AND MAINTENANCE	28

SAFETY GUIDELINES



WARNING! An authorized Provider or qualified technician must perform the initial setup of this scooter and must perform all of the procedures in this manual.

The symbols below are used throughout this owner's manual and on the scooter to identify warnings and important information. It is very important for you to read them and understand them completely.



WARNING! Indicates a potentially hazardous condition/situation. Failure to follow designated procedures can cause either personal injury, component damage, or malfunction. On the product, this icon is represented as a black symbol on a yellow triangle with a black border.



MANDATORY! These actions should be performed as specified. Failure to perform mandatory actions can cause personal injury and/or equipment damage. On the product, this icon is represented as a white symbol on a blue dot with a white border.



PROHIBITED! These actions are prohibited. These actions should not be performed at any time or in any circumstances. Performing a prohibited action can cause personal injury and/or equipment damage. On the product, this icon is represented as a black symbol with a red circle and red slash.

I. SAFETY

PRODUCT SAFETY SYMBOLS

The symbols below are used on the Travel Scooter to identify warnings, mandatory actions, and prohibited actions. It is very important for you to read and understand them completely.

NOTE: There are more warnings identified and explained in the Consumer Safety Guide that is included with your Travel Scooter. Please become familiar with all the warnings and safety information found in the Consumer Safety Guide and refer to this resource often.



Read and follow the information in the owner's manual.

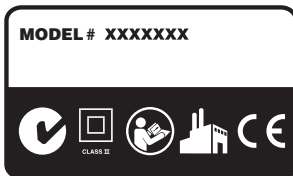

Scooter information label.



Fully charge batteries before operating.

Remove key from an unattended Travel Scooter.



Indicates tie-down points on the Travel Scooter.



Does not meet 7176-19 standards for occupied transport in a motor vehicle. When travelling in a motor vehicle, do not sit in your Travel Scooter.



Manufactured in.

I. SAFETY

GENERAL



MANDATORY! Do not operate your new Travel Scooter for the first time without completely reading and understanding this owner's manual and the Consumer Safety Guide.

Your Travel Scooter is a state-of-the-art life-enhancement device designed to increase mobility. We provide an extensive variety of products to best fit the individual needs of the Travel Scooter user. Please be aware that the final selection and purchasing decision regarding the type of Travel Scooter to be used is the responsibility of the Travel Scooter user who is capable of making such a decision and his/her healthcare professional (i.e., medical doctor, physical therapist, etc.).

The contents of this manual are based on the expectation that a mobility device expert has properly fitted the Travel Scooter to the user and has assisted the prescribing healthcare professional and/or the authorized Provider in the instruction process for the use of the product.

There are certain situations, including some medical conditions, where the Travel Scooter user will need to practice operating the Travel Scooter in the presence of a trained attendant. A trained attendant can be defined as a family member or care professional specially trained in assisting a Travel Scooter user in various daily living activities.

As you begin using your Travel Scooter during daily activities, you will probably encounter situations in which you will need some practice. Simply take your time and you will soon be in full and confident control as you maneuver through doorways, on and off elevators, up and down ramps, and over moderate terrain.

Additional general information can be found on the supplemental information sheets and booklets included in your Owner's Package. Please fully read and review the information, and keep it readily available for future reference.

Below are some precautions, tips, and other safety considerations that will help you become accustomed to operating the Travel Scooter safely.

PRE-RIDE SAFETY CHECK

Get to know the feel of your Travel Scooter and its capabilities. We recommend that you perform a safety check before each use to make sure your Travel Scooter operates smoothly and safely.

Perform the following inspections prior to using your Travel Scooter:

- Check the condition of the tires. Make sure they are not damaged or excessively worn.
- Check all electrical connections. Make sure they are tight and not corroded.
- Check all harness connections. Make sure they are secured properly.
- Check the brakes to ensure they operate properly.
- Check the battery condition meter to ensure the batteries are fully charged.
- Ensure the manual freewheel lever is in drive mode before sitting on the Travel Scooter.

If you discover a problem, contact your authorized Provider for assistance. Please refer to the Contact Information insert in your Owner's Package.

II. YOUR TRAVEL SCOOTER

TILLER CONSOLE

The tiller console houses all controls needed to drive your Travel Scooter, including the key switch, throttle control lever, horn button, speed adjustment dial, and the battery condition meter. Please refer to the *Travel Scooter Features Table* on the inside of the front cover of this owner's manual to determine which console figure to choose. See figures 1 through 4.



PROHIBITED! Do not expose the tiller console to moisture. In the event that the tiller console does become exposed to moisture, do not attempt to operate your Travel Scooter until the tiller console has dried thoroughly.

IDENTIFICATION KEY FOR FIGURES 1 THROUGH 4

- | | |
|----------------------------|--|
| 1. HORN | 6. CHARGER POWER CORD RECEPTACLE (TILLER PORT) |
| 2. KEY SWITCH | 7. OFF-BOARD CHARGER FUSE |
| 3. BATTERY CONDITION METER | 8. LIGHT FUSE |
| 4. SPEED ADJUSTMENT DIAL | 9. LIGHT SWITCH |
| 5. THROTTLE CONTROL LEVER | |

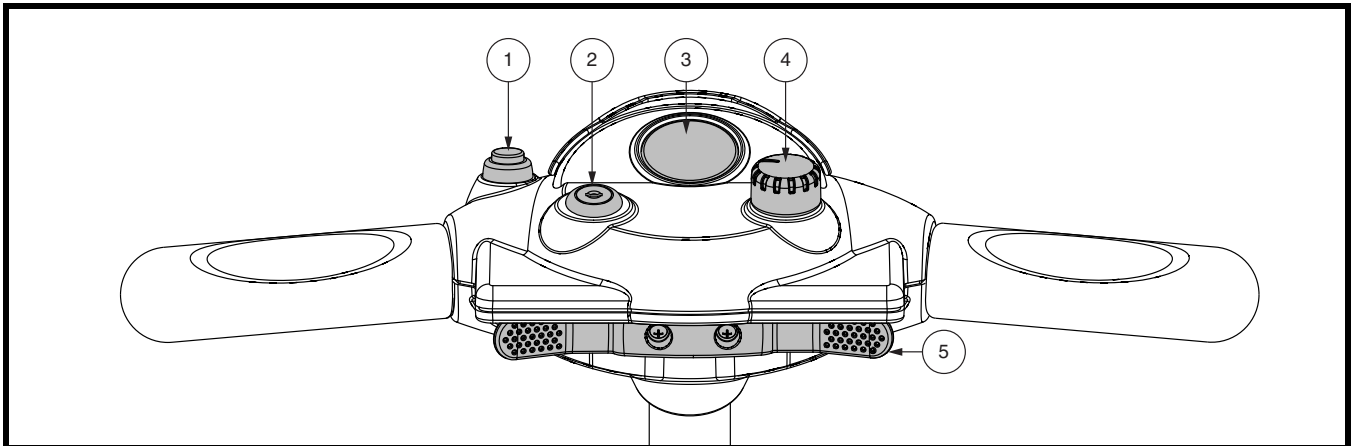

Figure 1. Tiller Console A

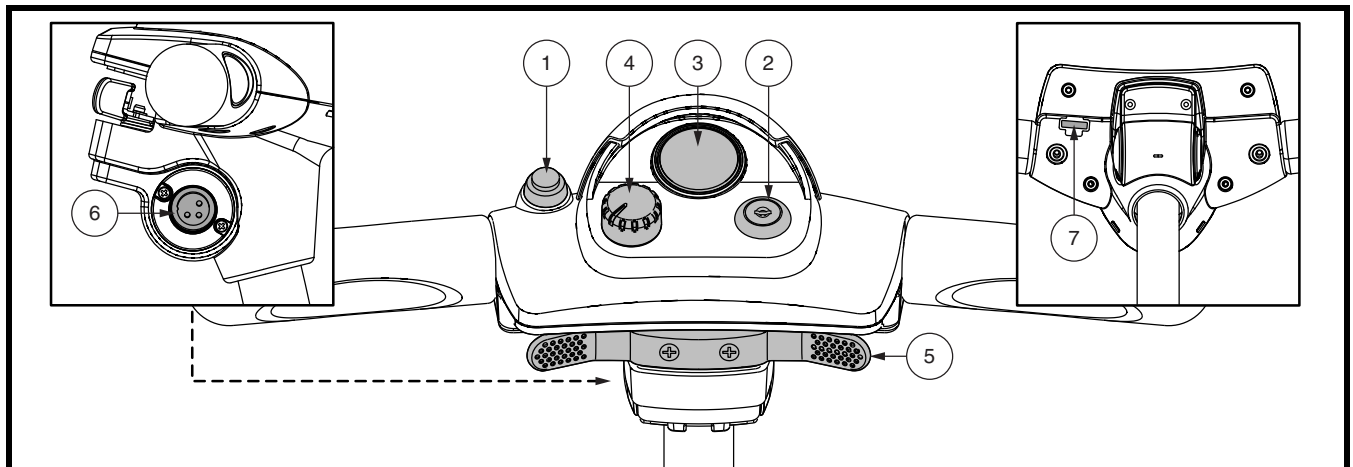

Figure 2. Tiller Console B

II. YOUR TRAVEL SCOOTER

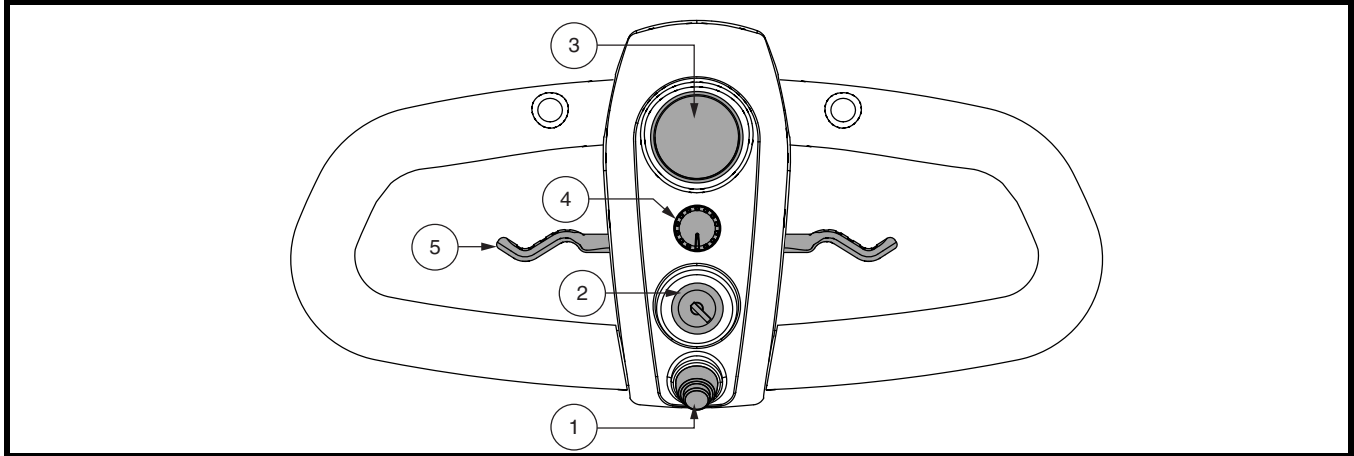

Figure 3. Tiller Console C

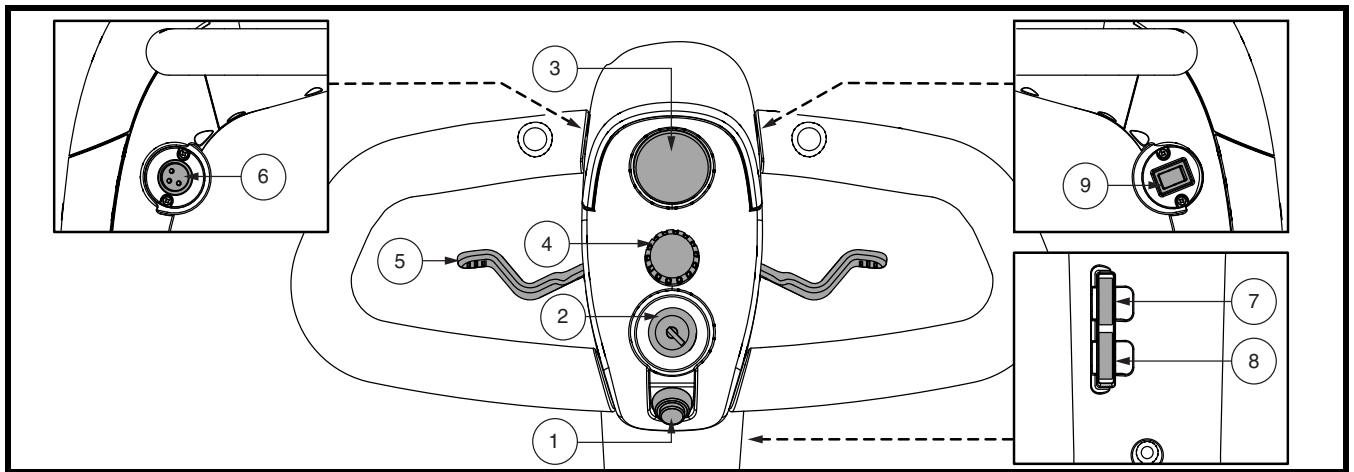

Figure 4. Tiller Console D

Horn Button

This button activates a warning horn. Your Travel Scooter must be turned on for the horn to be operational. Do not hesitate to use the warning horn when doing so may prevent accident or injury.

Key Switch

- Insert the key into the key switch and turn it clockwise to power up (turn on) your Travel Scooter.
- Turn the key counterclockwise to power down (turn off) your Travel Scooter.

Although the key can be left in the key switch when the Travel Scooter is powered down, we recommend removing it to prevent unauthorized use of your Travel Scooter.



WARNING! If the key is moved to the “off” position while your Travel Scooter is in motion, the electronic brakes will engage and your Travel Scooter will come to an abrupt stop!

Battery Condition Meter

When the key is fully inserted into the key switch and turned clockwise to power up your scooter, this meter indicates approximate battery strength. For further information on the battery condition meter, see III. “Batteries and Charging.”

II. YOUR TRAVEL SCOOTER

Speed Adjustment Dial 🐢 🐇

This dial allows you to preselect and limit your Travel Scooter's top speed.

- The image of the tortoise represents the slowest speed setting.
- The image of the hare represents the fastest speed setting.

Throttle Control Lever

This lever allows you to control the forward speed and the reverse speed of your Travel Scooter up to the maximum speed you preset with the speed adjustment dial.

- Place your right hand on the right handgrip and your left hand on the left handgrip.
- Use your right thumb to push the right side of the lever to disengage your Travel Scooter's brakes and move forward.
- Release the lever and allow your Travel Scooter to come to a complete stop before pushing the other side of the lever to move in reverse.
- When the throttle is completely released, it automatically returns to the center "stop" position and engages your Travel Scooter's brakes.

Lights Switch (If Equipped) ☰

This switch controls your Travel Scooter's lighting system. See figure 4.

- Toggle the switch forward to turn on the lighting system.
- Toggle the switch rearward to turn off the lighting system.



WARNING! Scooter users are required to use their lights when visibility is restricted — day or night.

REAR COMPONENTS

The manual freewheel lever, anti-tip wheels, and motor/transaxle assembly are located on your Travel Scooter as shown. See figure 5.



WARNING! Before placing your Travel Scooter into or taking it out of freewheel mode, remove the key from the key switch. Never sit on a Travel Scooter when it is in freewheel mode. Never put a Travel Scooter in freewheel mode on any incline.

Manual Freewheel Lever

Whenever you need or want to push your Travel Scooter for short distances, you can put it in freewheel mode.

1. Locate the manual freewheel lever at the top right of the rear section.
2. Push forward on the manual freewheel lever to disable the drive system and the brake system. You may now push your Travel Scooter.
3. Push the manual freewheel lever rearward to reengage the drive and the brake systems; this takes your Travel Scooter out of freewheel mode.

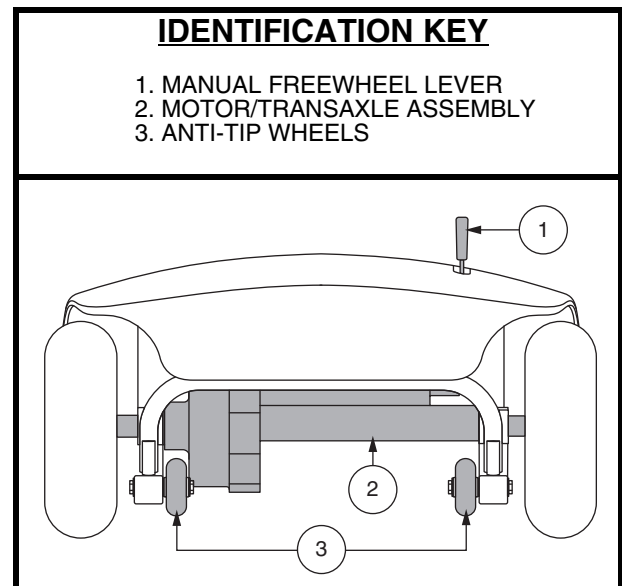

Figure 5. Rear Components

II. YOUR TRAVEL SCOOTER

WARNING! When your Travel Scooter is in freewheel mode, the braking system is disengaged.



- Disengage the drive motors only on a level surface.
- Ensure the key is removed from the key switch.
- Stand to the side of the Travel Scooter to engage or disengage freewheel mode. Never sit on a Travel Scooter to do this.
- After you have finished pushing your Travel Scooter, always return it to the drive mode to lock the brakes.

Motor/Transaxle Assembly

The motor/transaxle assembly is an electromechanical unit that converts electrical energy from your Travel Scooter's batteries into the controlled mechanical energy that drives the Travel Scooter's wheels.

Anti-Tip Wheels

The anti-tip wheels are an integral and important safety feature of your Travel Scooter. They are bolted to the frame at the rear of the Travel Scooter.



PROHIBITED! Do not remove the anti-tip wheels or modify your Travel Scooter in any way that is not authorized by your Provider.



WARNING! The anti-tip wheels may cause interference with the smooth transition of your Travel Scooter when ascending or descending a curb. Contact your authorized Provider for more information.

Main Circuit Breaker (Reset Button)

When the voltage in your Travel Scooter's batteries becomes low or the Travel Scooter is heavily strained because of excessive loads or steep inclines, the main circuit breaker may trip to protect the motor and electronics from damage. See figure 6.

- The main circuit breaker reset button pops out when the breaker trips.
- When the breaker trips, the entire electrical system of your Travel Scooter shuts down.
- Allow a minute or two for your Travel Scooter's electronics to "rest."
- Push in the reset button to reset the main circuit breaker.
- If the main circuit breaker trips frequently, you may need to charge your batteries more often. You may also need to have your authorized Provider perform a load test on your Travel Scooter's batteries.
- If the main circuit breaker trips repeatedly, see your authorized Provider for service.

III. YOUR TRAVEL SCOOTER

BATTERY PACK

Your Travel Scooter is equipped with an innovative, easy-to-remove battery pack. A handle on the top of the battery pack makes it easy to lift the pack off of the Travel Scooter with one hand. The battery pack contains two rechargeable batteries, and may contain the charger power cord receptacle, the main circuit breaker (reset button), and the battery pack fuse. See **figure 6**.

IDENTIFICATION KEY

- | | |
|----------------------------------|--|
| 1. BATTERY PACK | 5. MAIN CIRCUIT BREAKER (RESET BUTTON) |
| 2. BATTERY PACK HANDLE | 6. BATTERY CABLE WIRING HARNESS |
| 3. CHARGER POWER CORD RECEPTACLE | 7. BATTERY TERMINALS |
| 4. BATTERY PACK FUSE | 8. TILLER CONSOLE FUSE |

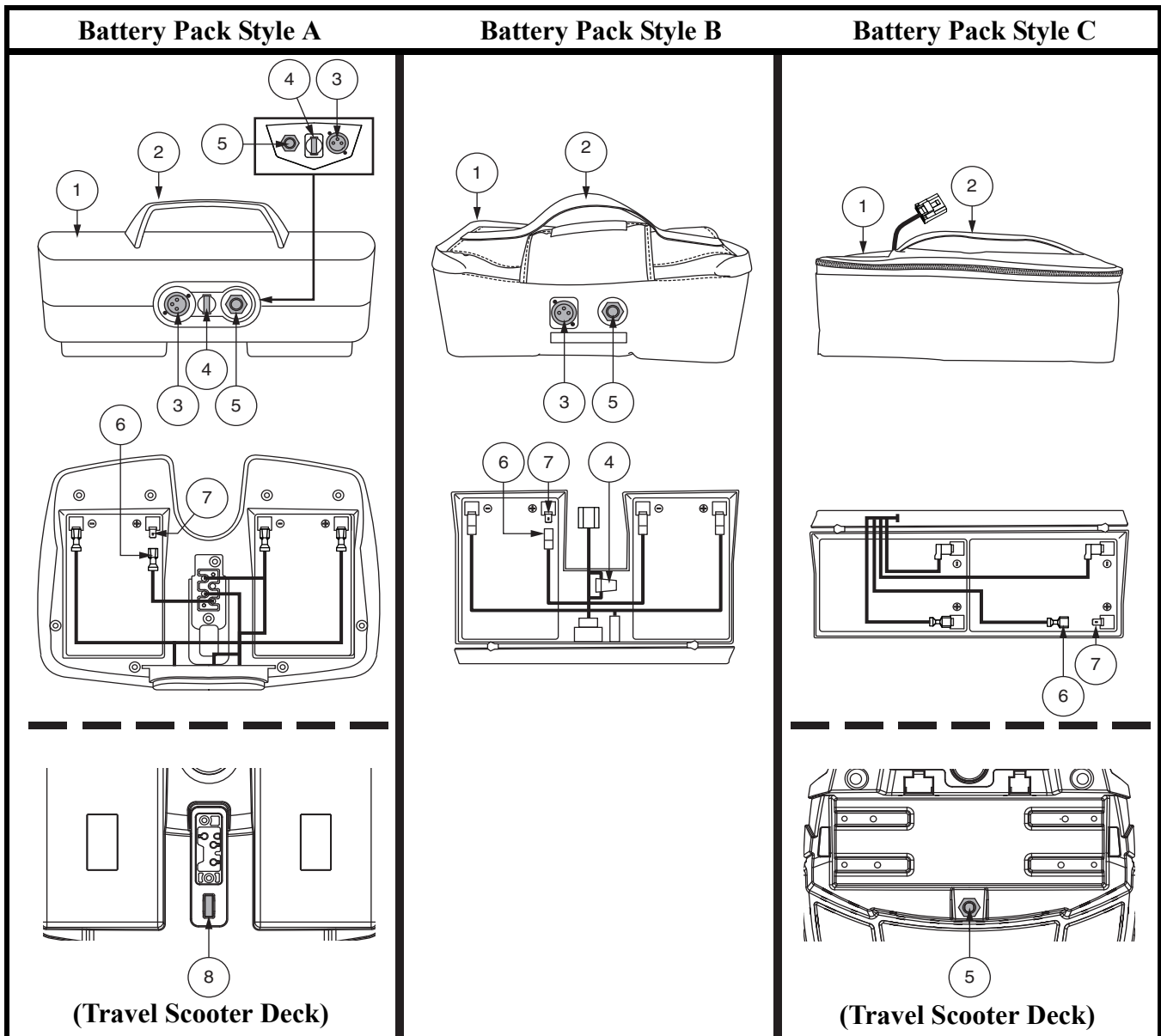

Figure 6. Battery Pack

II. YOUR TRAVEL SCOOTER

Charger Power Cord Receptacle

The 3-pin end of the charger power cord plugs into this receptacle. See figures 7 and 8.

TILLER CONSOLE FUSE (IF EQUIPPED)

The fuse located under the battery pack protects the tiller console electronics. See figure 6. In the event any component of the tiller console is not responding, check this fuse. See VII. “Basic Troubleshooting” for fuse replacement instructions.

OFF-BOARD BATTERY CHARGER

The off-board battery charger, when plugged into the charger power cord receptacle and a standard electrical outlet, charges the Travel Scooter’s batteries. See figure 9.

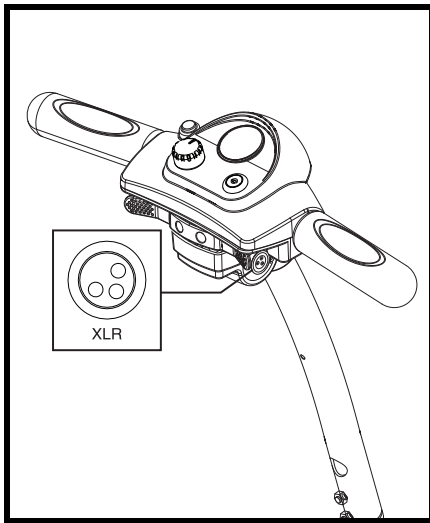

Figure 7. Charger Power Cord Receptacle (Tiller Mounted)

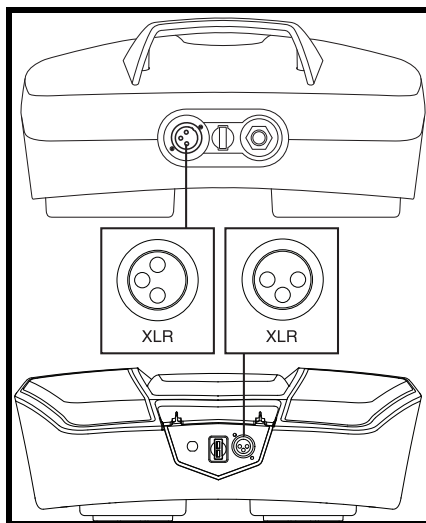

Figure 8. Charger Power Cord Receptacle (Battery Pack)

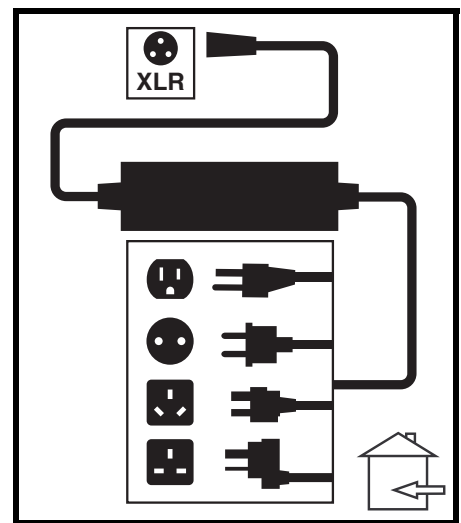

Figure 9. Off-board Battery Charger

SECUREMENT POINTS

Always secure the Travel Scooter in a forward-facing position in the vehicle. Attach the four tie-down straps to the designated securement points. See figure 10. Tighten the straps to sufficiently remove all slack. Never attach tie-downs to adjustable, moving, or removable parts of the Travel Scooter such as armrests, shrouds, and wheels. These items should be removed. Position the anchor points for the rear tie-down straps directly behind the rear securement points on the Travel Scooter. The front tie-down straps should anchor to floor points that are spaced wider than the Travel Scooter to provide increased lateral stability.



WARNING! Ensure Travel Scooters are properly secured to the motor vehicle during transport. Scooters that are not properly secured can become a hazard to the user and to other vehicle passengers in the event of a crash, sudden stopping, or swerving, as the Travel Scooter could tip or slide out of place.

II. YOUR TRAVEL SCOOTER

IDENTIFICATION KEY

1. Front Securement Points (3-wheel models)
 - 1a. Models 83 and 84 only
 - 1b. Models 36, 40X, 44X, 40E, 44E, 40LX, 44LX, 50LX, 54LX, 53, 53HD, 54, 54HD, 73, and 74
2. Front Securement Points (4-wheel models)
3. Rear Securement Points

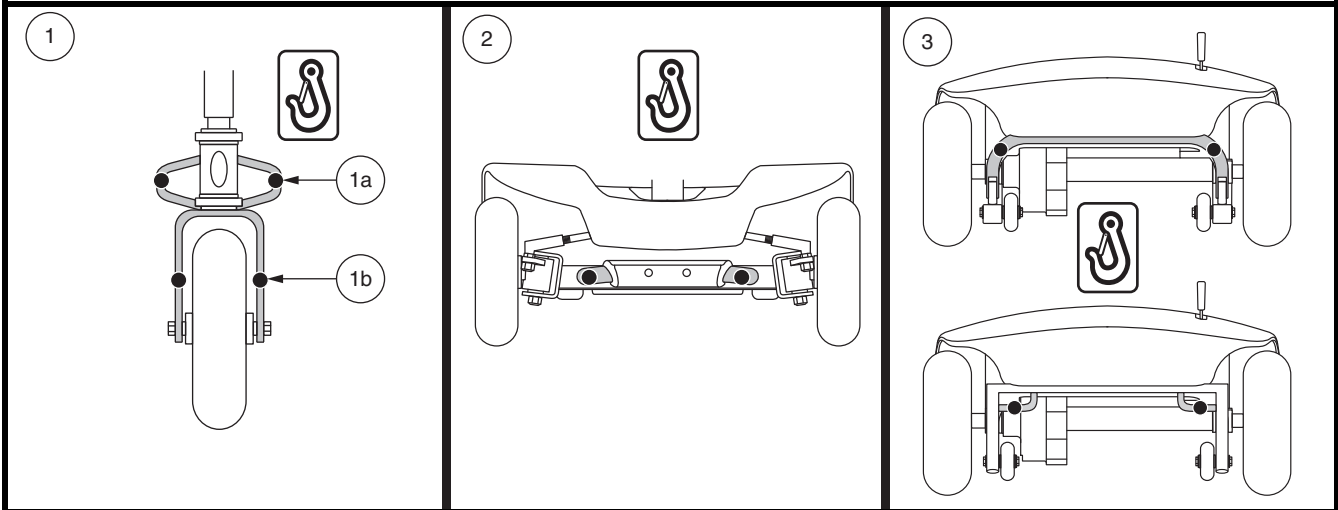

Figure 10. Securement Points (Identified with black dots)

SHROUD PANELS

On certain models, you can change the color of your Travel Scooter by removing the colored plastic shroud panel pieces and replacing them with one of the other supplied sets. The panels are held in place by a hook and loop reusable fastener. See **Travel Scooter Features Table (inside front cover)**.

To remove the shroud panel pieces:

1. Use your finger to locate the push hole behind each shroud piece.
2. Push through the hole to separate the piece from the Travel Scooter. See **figure 11**.

To remove the tiller console visor:

1. Gently pull the top of the visor away from the tiller console, then slowly lift it up and away from the tiller console. See **figure 12**.

To reinstall the shroud pieces, place each piece in its appropriate location and push with slight pressure to secure the reusable fastener.

NOTE: When installing the front and rear fender panels, make sure the tab at the bottom of each panel is inserted into the tab opening before securing the panel. See **figure 11**.

IDENTIFICATION KEY

1. Rear Fender Panel
2. Front Fender Panel

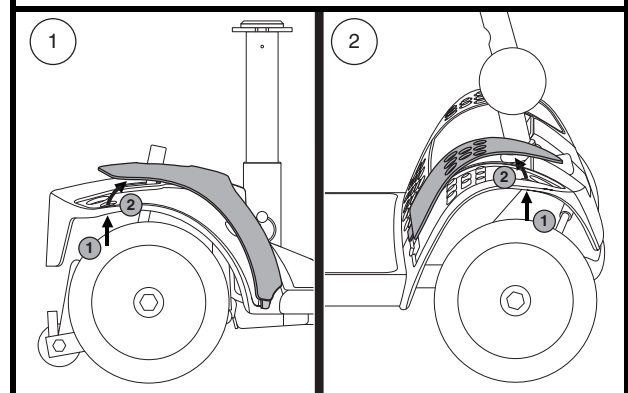

Figure 11. Fender Panels

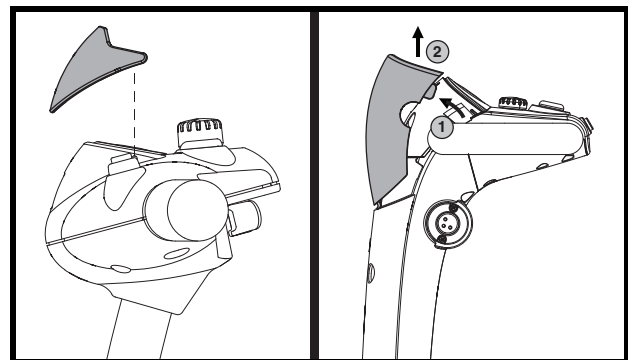

Figure 12. Tiller Console Visor

III. BATTERIES AND CHARGING

BATTERIES AND CHARGING

Your Travel Scooter requires two long-lasting, 12-volt, deep-cycle batteries that are sealed and maintenance free. They are recharged by the supplied off-board charging system.

- Charge your Travel Scooter's batteries for at least 8 to 14 hours prior to using it for the first time.
- Keep the batteries fully charged to keep your Travel Scooter running smoothly.

READING YOUR BATTERY VOLTAGE

The battery condition meter on the tiller console indicates the approximate strength of your batteries using a color code. From right to left on the meter, green indicates fully charged batteries, yellow a draining charge, and red indicates that an immediate recharge is necessary. See figure 13. To ensure the highest accuracy, the battery condition meter should be checked while operating your Travel Scooter at full speed on a dry, level surface.

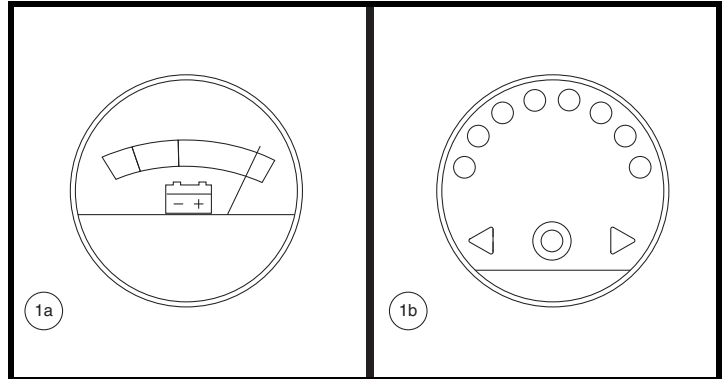

Figure 13. Battery Condition Meter

CHARGING YOUR BATTERIES

NOTE: With some models, the battery pack can be charged on or off the Travel Scooter. See Travel Scooter Features Table.



PROHIBITED! Removal of grounding prong can create electrical hazard. If necessary, properly install an approved 3-pronged adapter to an electrical outlet having 2-pronged plug access.



PROHIBITED! Never use an extension cord to plug in your battery charger. Plug the charger directly into a properly wired standard electrical outlet.



PROHIBITED! Do not allow unsupervised children to play near the Travel Scooter while the batteries are charging. We recommend that you do not charge the batteries while the Travel Scooter is occupied.



MANDATORY! Read the battery charging instructions in this manual and in the manual supplied with the battery charger before charging the batteries.



WARNING! Explosive gases may be generated while charging the batteries. Keep the Travel Scooter and battery charger away from sources of ignition such as flames or sparks and provide adequate ventilation when charging the batteries.

WARNING! You must recharge your Travel Scooter's batteries with the supplied off-board charger. Do not use an automotive-type battery charger.

WARNING! Inspect the battery charger, wiring, and connectors for damage before each use. Contact your authorized Provider if damage is found.



WARNING! Do not attempt to open the battery charger case. If the battery charger does not appear to be working correctly, contact your authorized Provider.

WARNING! If the battery charger is equipped with cooling slots, then do not attempt to insert objects through these slots.

WARNING! Be aware that the battery charger case may become hot during charging. Avoid skin contact and do not place on surfaces that may be affected by heat.

III. BATTERIES AND CHARGING



WARNING! If your battery charger has not been tested and approved for outdoor use, then do not expose it to adverse or extreme weather conditions. If the battery charger is exposed to adverse or extreme weather conditions, then it must be allowed to adjust to the difference in environmental conditions before use indoors. Refer to the manual supplied with the battery charger for more information.

Follow the 6 easy steps in figure 14 to charge your batteries safely:

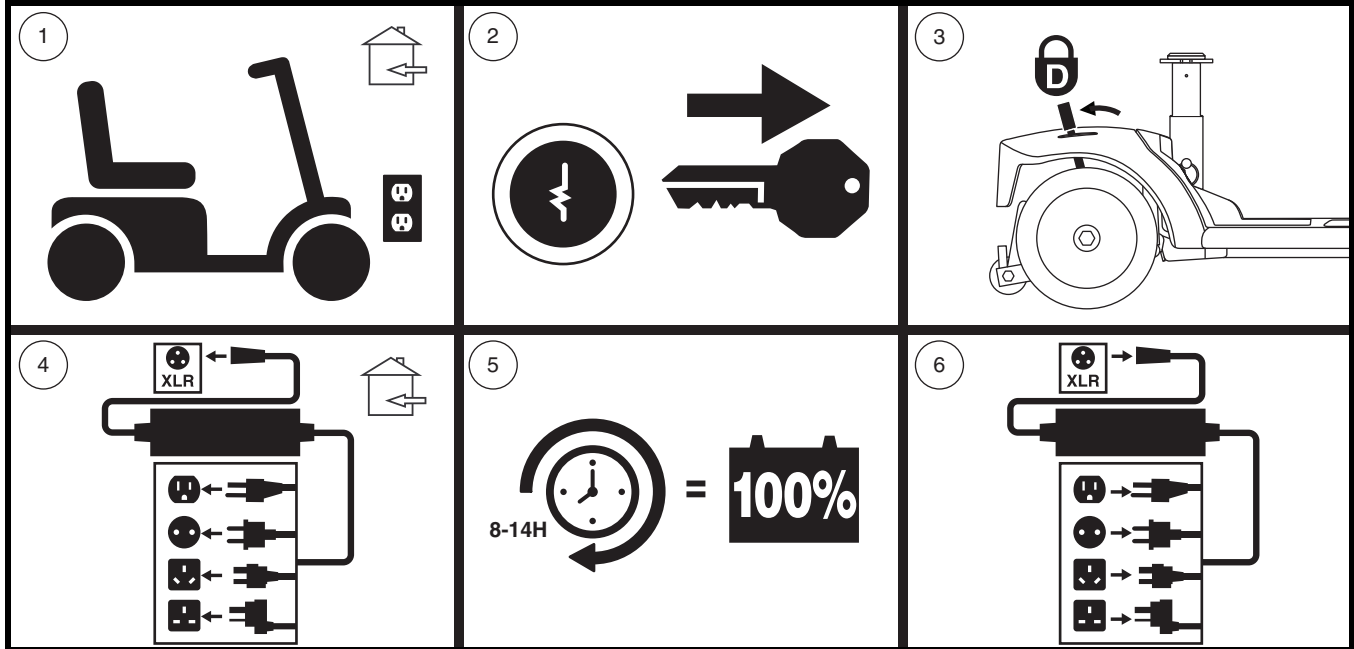

Figure 14. Battery Charging Procedures Diagram



WARNING! The LED lights on the charger indicate different charger conditions at various times. If the LED does not indicate that charging is complete within 24 hours, unplug the charger from the outlet and contact your Provider. Refer to the operating instructions supplied with the charger for a complete explanation of these indicators.

NOTE: There is a charger inhibit function on your Travel Scooter. The Travel Scooter will not run and the battery condition meter will not operate while the batteries are charging (when the battery pack is being charged on the Travel Scooter).

FREQUENTLY ASKED QUESTIONS

How does the charger work?

When your Travel Scooter's battery voltage is low, the charger works harder, sending more electrical current to the batteries to bring up their charge. As the batteries approach a full charge, the charger sends less and less electrical current. When the batteries are fully charged, the current sent from the charger is at nearly zero amperage. Therefore, when the charger is plugged in, it maintains the charge on your Travel Scooter's batteries, but does not overcharge them. Refer to the manual supplied with the battery charger for charging instructions.

Can I use a different charger?

Chargers are selected precisely for particular applications and are especially matched to the type, size, and chemical formulation of specific batteries. For the safest and most efficient charging of your Travel Scooter's batteries, we recommend use of the charger supplied as original equipment with your product only. Any charging method resulting in batteries being charged individually is especially prohibited.

III. BATTERIES AND CHARGING

What if my Travel Scooter's batteries will not charge?

- Ensure that the fuse on the battery pack is in working condition. See figure 6 or 7.
- Ensure both ends of the charger power cord are inserted fully.

How often must I charge the batteries?

Two major factors must be considered when deciding how often to charge your Travel Scooter's batteries:

- All day use on a daily basis.
- Infrequent or sporadic use.

With these considerations in mind, you can determine how often and for how long you should charge your Travel Scooter's batteries. The battery charger was designed so that it will not overcharge your Travel Scooter's batteries. However, you may encounter some problems if you do not charge your batteries often enough and if you do not charge them on a regular basis. Following the guidelines below will provide safe and reliable battery operation and charging.

- If you use your Travel Scooter daily, charge its batteries as soon as you finish using it for the day. Your Travel Scooter will be ready each morning. We recommend that you charge your Travel Scooter's batteries for at least 8 to 14 hours after daily use. We recommend that you charge the batteries for an additional 4 hours after the battery charger indicates that charging is complete.
- If you use your Travel Scooter once a week or less, charge its batteries at least once a week for at least 24 hours.

NOTE: Keep your batteries fully charged and avoid deeply discharging your batteries. Refer to the manual supplied with the battery charger for charging instructions. We recommend charging your batteries for at least 48 continuous hours once per month to improve battery performance and battery life.

How can I ensure maximum battery life?

Fully charged deep-cycle batteries provide reliable performance and extended battery life. Keep your Travel Scooter's batteries fully charged whenever possible. Protect your Travel Scooter and batteries from extreme heat or cold. Batteries that are regularly and deeply discharged, infrequently charged, stored in extreme temperatures, or stored without a full charge may be permanently damaged, causing unreliable performance and limited service life.

NOTE: To extend battery life, always turn off Travel Scooter and remove the key when not in use.

How can I get maximum range or distance per charge?

Rarely will you have ideal driving conditions—smooth, flat, hard driving surfaces with no wind or curves. Often, you will face hills, sidewalk cracks, uneven and loosely packed surfaces, curves, and wind, all of which affect the distance or running time per battery charge. Below are a few suggestions for obtaining the maximum range per battery charge.

- Always fully charge your Travel Scooter's batteries prior to daily use.
- Plan your route ahead to avoid as many hills, cracked, broken, or soft surfaces as possible.
- Limit your baggage weight to essential items.
- Try to maintain an even speed while your Travel Scooter is in motion.
- Avoid stop-and-go driving.
- We recommend charging your batteries for at least 48 continuous hours once per month to improve battery performance and battery life.
- Make sure all harness connections are secured properly.

III. BATTERIES AND CHARGING

What type and size of battery should I use?

Your Travel Scooter requires two deep cycle batteries. We recommend only sealed, maintenance-free types such as AGM or Gel-Cell. Do not use wet-cell batteries, which have removable caps. Refer to the specifications table for size as batteries differ depending on manufacture.



WARNING! Corrosive chemicals are contained in batteries. Use only AGM or Gel-Cell batteries to reduce the risk of leakage or explosive conditions.

NOTE: Sealed batteries are not serviceable. Do not remove the caps.

Why do my new batteries seem weak?

Deep-cycle batteries employ a different chemical technology than that used in car batteries, nickel-cadmium batteries (nicads), and other common battery types. Deep-cycle batteries are specifically designed to provide power, drain down their charge, and then accept a relatively quick recharge (8 to 14 hours).

We work closely with our battery manufacturer to provide batteries that best suit your Travel Scooter's specific electrical demands. Fresh batteries are shipped fully charged to our customers. During shipping, the batteries may encounter temperature extremes that can influence their initial performance. Heat diminishes the charge on the battery; cold slows the available power and extends the time needed to recharge the battery.

It may take a few days for the temperature of your Travel Scooter's batteries to stabilize and adjust to their new room or ambient temperature. More importantly, it takes a few charging cycles (partial draining followed by full recharging) to establish the critical chemical balance that is essential to a deep-cycle battery's peak performance and long life.

Follow these steps to properly break in your Travel Scooter's new batteries for maximum efficiency and service life.

1. Fully recharge any new battery prior to its initial use. This charging cycle brings the battery up to about 88% of its peak performance level.
2. Operate your new Travel Scooter in familiar and safe areas. Drive slowly at first, and do not travel too far from your home or familiar surroundings until you have become accustomed to your Travel Scooter's controls and have properly broken in your Travel Scooter's batteries.
3. Fully recharge the batteries. They should be at over 90% of their peak performance level.
4. Operate your Travel Scooter again, then fully recharge the batteries.
5. After four or five charging cycles, the batteries are able to receive a charge of 100% of their peak performance level and are able to last for an extended period of time.

What about public transportation?

If you intend to use public transportation with your Travel Scooter, you must contact the transportation provider in advance to determine their specific requirements.

III. BATTERIES AND CHARGING

How do I change a battery in my Travel Scooter?



MANDATORY! Battery posts, terminals, and related accessories contain lead and lead compounds. Wear goggles and gloves when handling batteries and wash hands after handling.



WARNING! Always use two batteries of the exact same type, chemistry, and amp-hour (Ah) capacity. Refer to the product specifications insert and in the manual supplied with the battery charger for recommended type and capacities.

WARNING! Do not mix old and new batteries. Always replace both batteries at the same time.



WARNING! Contact your Provider if you have any questions regarding the batteries in your Travel Scooter.

WARNING! Do not replace the batteries while the Travel Scooter is occupied.

WARNING! The batteries on your Travel Scooter should only be serviced or replaced by an authorized Provider or a qualified technician.



PROHIBITED! Keep tools and other metal objects away from battery terminals. Contact with tools can cause electrical shock.

You may need the following to change your batteries:

- Metric/standard socket set and ratchet
- Adjustable wrench



WARNING! Do not lift beyond your physical capability. Ask for assistance when necessary while disassembling or assembling your scooter.

WARNING! Do not pull on electrical harness wires directly to detach them from the Travel Scooter. Always grasp the connector itself when disconnecting the harness to prevent wire damage.

To change batteries in Battery Pack Style A (see figure 6):

1. Remove the battery pack from the Travel Scooter.
2. Carefully turn the pack upside down.
3. Remove the screws from the perimeter of the battery pack.
4. Carefully turn the pack right side up and remove the lid.
5. Disconnect the black (-) and red (+) battery cables from the battery terminals of each battery.
6. Remove the old batteries.
7. Place the new batteries into the battery pack.
8. Connect the red battery cable to the positive (+) battery terminal of each battery.
9. Connect the black battery cable to the negative (-) battery terminal of each battery.
10. Position the lid back onto the battery pack ensuring all wires are inside the pack so they don't become pinched.
11. Carefully turn the pack upside down.
12. Reinstall all screws and tighten.

III. BATTERIES AND CHARGING

NOTE: Some batteries require the removal of a nut and bolt when disconnecting the battery cable from the battery terminal. See figure 15.

To change batteries in Battery Pack Style B (see figure 6):

1. Disconnect the battery harness and remove the battery pack from the Travel Scooter. See figure 16.
2. Unzip the battery pack to expose the batteries.
3. Disconnect the black (-) and red (+) battery cables from the battery terminals of each battery.
4. Remove the old batteries.
5. Place the new batteries into the battery pack.
6. Connect the red battery cable to the positive (+) battery terminal of each battery.
7. Connect the black battery cable to the negative (-) battery terminal of each battery.
8. Completely zip the battery pack.
9. Reinstall the battery pack and connect the battery harness.

To change batteries in Battery Pack Style C (see figure 6):

1. Remove the seat and rear shroud.
2. Disconnect the battery harnesses and tie-down strap then remove the battery pack from the Travel Scooter. See figure 16.
3. Unzip the battery pack to expose the batteries.
4. Disconnect the black (-) and red (+) battery cables from the battery terminals of each battery.
5. Remove the old batteries.
6. Place the new batteries into the battery pack.
7. Connect the red battery cable to the positive (+) battery terminal of each battery.
8. Connect the black battery cable to the negative (-) battery terminal of each battery.
9. Completely zip the battery pack closed.
10. Reinstall the battery pack then connect the battery harnesses and battery tie-down strap.
11. Reinstall the rear shroud and seat.

NOTE: If you encounter a damaged or cracked battery, immediately enclose it in a plastic bag and contact your local waste disposal agency or authorized Provider for instructions on disposal and battery recycling which is our recommended course of action.

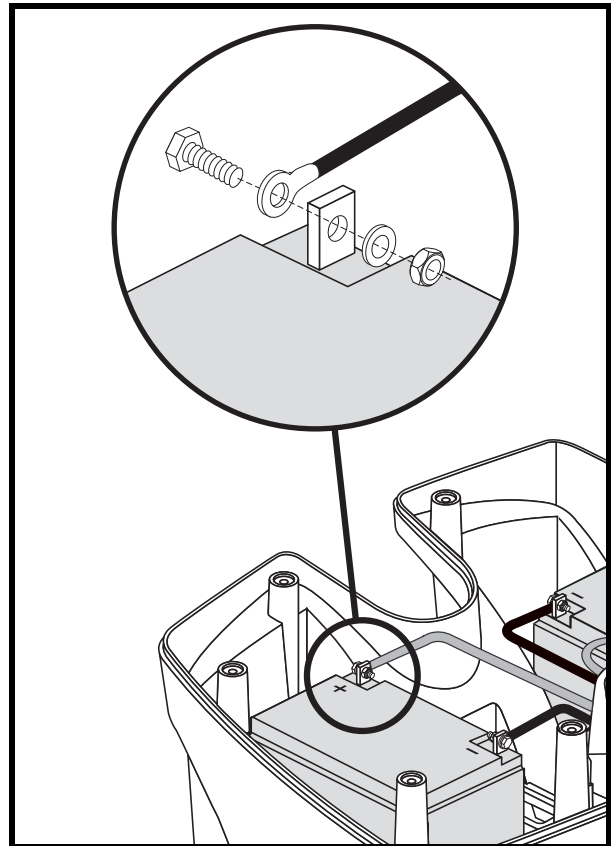

Figure 15. Disconnecting the Battery Cable on a 17-22 Ah Battery Box

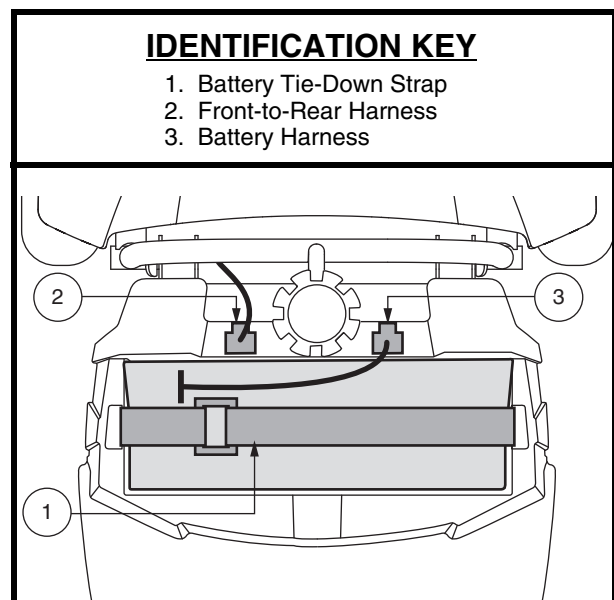

Figure 16. Battery Tie-down Strap

IV. OPERATION

BEFORE GETTING ONTO YOUR TRAVEL SCOOTER

- Have you fully charged the batteries? See III. “Batteries and Charging.”
- Is the manual freewheel lever in the drive (rearward) position? Never leave the manual freewheel lever in the forward position unless you are manually pushing your Travel Scooter.
- Ensure the tiller lock knob is in the unlocked position. See VI. “Disassembly and Assembly.”

GETTING ONTO YOUR TRAVEL SCOOTER

1. Make certain that the key is removed from the key switch.



WARNING! Never attempt to get onto or off of your Travel Scooter without first removing the key from the key switch. This will prevent the Travel Scooter from moving if accidental throttle control lever contact is made.

2. Stand at the side of your Travel Scooter.
3. Disengage the seat rotation lever and rotate the seat until it is facing you.
4. Make certain that the seat is secured into position.
5. Position yourself comfortably and securely in the seat.
6. Disengage the seat rotation lever and rotate the seat until you are facing forward.
7. Make certain that the seat is secured into position.
8. Make certain that your feet are safely on the floorboard.

PRE-RIDE ADJUSTMENTS AND CHECKS

- Is the seat at the proper height? See V. “Comfort Adjustments.”
- Is the seat secured into place?
- Is the tiller at a comfortable setting and secured into place? See V. “Comfort Adjustments.”
- Is the key fully inserted into the key switch and turned clockwise to the “on” position?
- Does the Travel Scooter’s horn work properly?
- Is your proposed path clear of people, pets, and obstacles?
- Have you planned your route to avoid adverse terrain and as many inclines as possible?

OPERATING YOUR TRAVEL SCOOTER

WARNING! The following can adversely affect steering and stability while operating your Travel Scooter:



- **Holding onto or attaching a leash to walk your pet.**
- **Carrying passengers (including pets).**
- **Hanging any article from the tiller.**
- **Towing or being pushed by another motorized vehicle.**

WARNING! Keep both hands on the tiller and your feet on the floorboard at all times while operating your Travel Scooter. This driving position gives you the most control over your vehicle.

- Set the speed adjustment dial to your desired speed.
- Press your thumb against the appropriate side of the throttle control lever.
- The electromechanical disc park brake automatically disengages and the Travel Scooter accelerates smoothly to the speed you preselected with the speed adjustment dial.
- Pull on the left handgrip to steer your Travel Scooter to the left.
- Pull on the right handgrip to steer your Travel Scooter to the right.
- Move the tiller to the center position to drive straight ahead.
- To stop, slowly release the throttle control lever. The electronic brakes will automatically engage when your Travel Scooter comes to a stop.

IV. OPERATION

NOTE: *Your Travel Scooter's reverse speed is slower than that of the forward speed you preset with the speed adjustment dial.*

GETTING OFF OF YOUR TRAVEL SCOOTER

1. Bring your Travel Scooter to a complete stop.
2. Remove the key from the key switch.



WARNING! Never attempt to get onto or off of your Travel Scooter without first removing the key from the key switch. This will prevent the Travel Scooter from moving if accidental throttle control lever contact is made.

3. Disengage the seat rotation lever and rotate the seat until you are facing toward the side of your Travel Scooter.
4. Make certain that the seat is secured into position.
5. Carefully and safely get out of the seat and stand to the side of your Travel Scooter.
6. You can leave the seat facing to the side to facilitate boarding your Travel Scooter next time.

POWER DOWN TIMER FEATURE

Your Travel Scooter is equipped with an energy saving automatic power down timer feature designed to preserve your Travel Scooter's battery life. If you mistakenly leave the key in the key switch and in the "on" position but do not use your Travel Scooter for approximately 20 minutes, the Travel Scooter's controller shuts down automatically.

If the power down timer feature takes effect, perform the following steps to resume normal operation.

1. Remove the key from the key switch.
2. Reinsert the key and power up your Travel Scooter.

V. COMFORT ADJUSTMENTS

TILLER ANGLE ADJUSTMENT (See figure 17)



WARNING! Remove the key from the key switch before adjusting the tiller or the seat. Never attempt to adjust the tiller or the seat while the Travel Scooter is in motion.

NOTE: In order to fully lower the tiller, you must first remove the seat and battery pack. Remove the seat by pulling it straight up and off of the Travel Scooter.

SEAT ROTATION ADJUSTMENT

The seat rotation lever, located on the right side of the seat base, secures the seat into several positions. See figure 18.

1. Pull up on the seat rotation lever to disengage the seat.
2. Rotate the seat to the desired position.
3. Release the lever to secure the seat into place.

ARMREST WIDTH ADJUSTMENT

The armrest width can be adjusted inward or outward.

1. Loosen the armrest adjustment knobs. See figure 18.
2. Use the attached ring to pull and remove the detent pins.
3. Slide the armrests in or out to the desired width.
4. Align the adjustment holes on the seat frame and armrest, then reinsert the detent pins.
5. Tighten the armrest adjustment knobs.

NOTE: Pivot the armrests upward to aid in getting onto and off of your Travel Scooter.

SEAT HEIGHT ADJUSTMENT

The seat can be repositioned to different heights. See figure 19.

1. Remove the seat and battery pack from your Travel Scooter.
2. Use the attached ring to pull and remove the detent pin from the lower seat post.
3. Raise or lower the upper seat post to the desired seat height.
4. While holding the upper seat post at that height, align the adjustment holes of the upper and lower seat posts.
5. Fully insert the detent pin.
6. Replace the battery pack and seat.

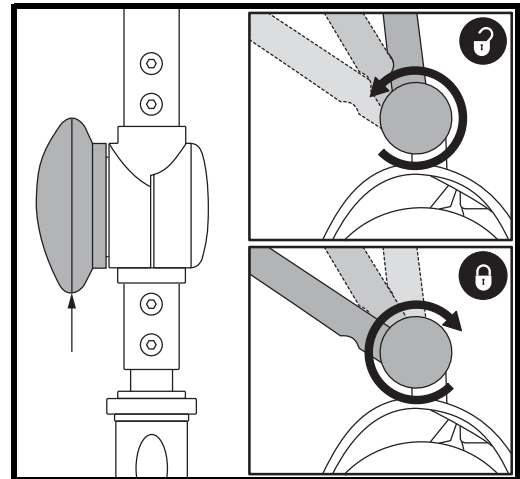

Figure 17. Tiller Adjustment Knob

IDENTIFICATION KEY

1. Armrest Adjustment Knobs
2. Detent Pins
3. Seat Rotation Lever

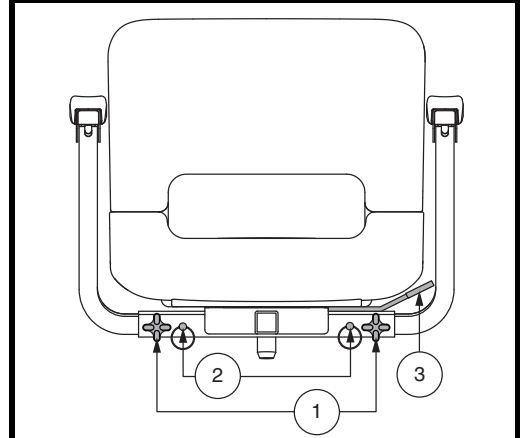

Figure 18. Seat Adjustments

IDENTIFICATION KEY

1. Upper Seat Post
2. Lower Seat Post
3. Detent Pin

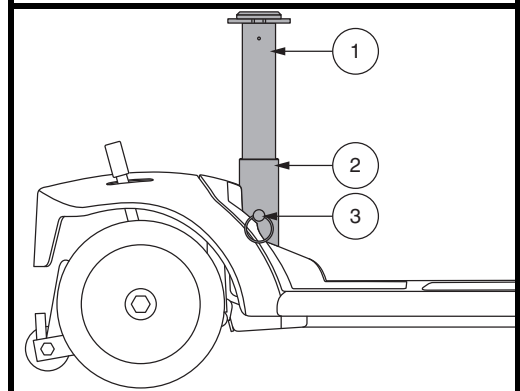

Figure 19. Seat Height Adjustment

V. COMFORT ADJUSTMENTS

SEAT SUSPENSION ADJUSTMENT (IF EQUIPPED)

The seat post acts as a shock absorber and can be adjusted for different degrees of ride comfort. Use the set screws that are visible through the adjustment window on the side of the post as a guide when making adjustments. Slide the rubber boot towards the top of the post to expose the setscrews. See **figure 20**.

To make seatpost adjustments:

1. Remove the seat from the Travel Scooter.
2. Remove the upper seat post from the Travel Scooter by removing the detent pin from the lower portion of the seat post, then lifting the post straight up and off the Travel Scooter. See **figure 19**.
3. Insert a 13 mm socket with an extension into the bottom of the post. See **figure 20**.
4. Rotate clockwise to soften the ride or rotate counterclockwise to stiffen the ride.
5. Reinstall the seat post and seat.

POSITIONING BELT (OPTIONAL)

Your scooter seat may be equipped with an auto-type positioning belt that can be adjusted for operator comfort. See **figure 22 or 23**. The positioning belt is designed to help support the operator so that he or she does not slide down or forward in the seat. The positioning belt is not designed for use as a restraining device.



WARNING! The positioning belt should be secured at all times. Never allow the positioning belt to hang or drag on the floor as it may become entangled.

To install the positioning belt (if required):

1. Remove the seat from your scooter.
2. Place the seat upside down so that you can see the bottom of the seat base. See **figure 21**.
3. Use a wrench to remove the two rear bolts on the outermost part of the seat frame.
4. Insert the bolt through the appropriate ends of the positioning belt and then reinstall the bolts back into the seat frame.
5. Tighten the bolts.

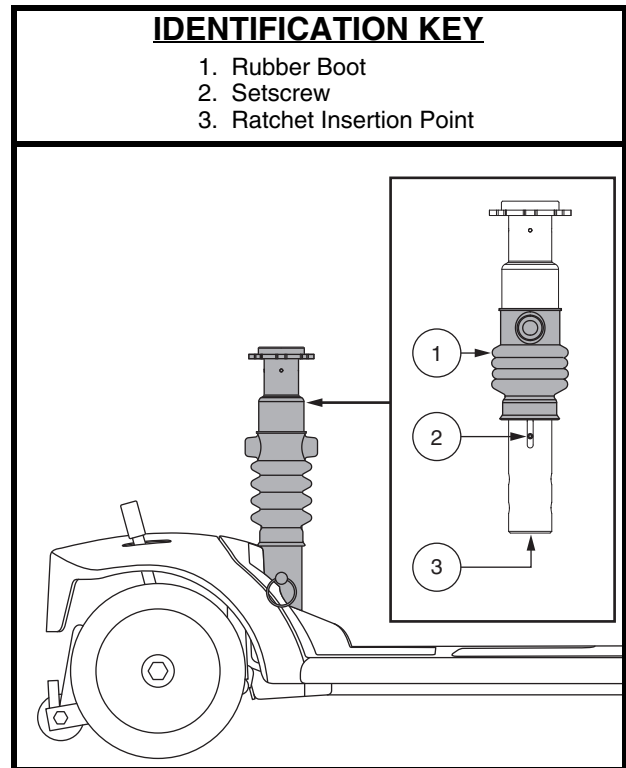

Figure 20. Seat Suspension Adjustment

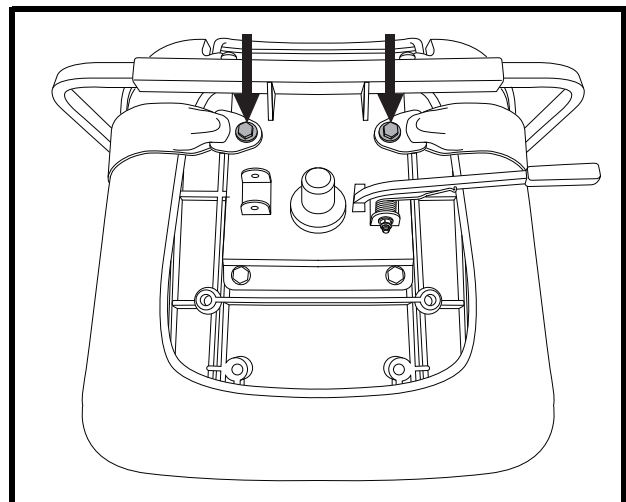

Figure 21. Positioning Belt Bolts

V. COMFORT ADJUSTMENTS

Metal tab style positioning belt

To adjust the positioning belt for operator comfort:

1. Insert the metal tab on the right side of the belt into the plastic housing on the opposite strap until you hear a “click.” See figure 22.
2. Pull the strap on the right side of the belt until it is secure, but not so tight as to cause discomfort.

To release the positioning belt:

1. Press the push button mechanism on the plastic housing.

Reusable hook and loop fastener style positioning belt

To adjust the positioning belt for operator comfort:

1. Align the two sides of the belt placing the looped-end side directly above the coarser side (“hook”) of the opposite belt. Press firmly together to fasten. See figure 23.

To release the positioning belt:

1. Grasp the looped-end side of the belt and pull up to detach from the other side of the belt.

MANDATORY! Make sure the positioning belt is properly secured to the scooter and is adjusted for operator comfort before each use.



MANDATORY! Inspect the positioning belt for loose parts or damage, including tears, worn spots, bent hardware, or damaged latch mechanisms, dirt or debris, before each use of the scooter. If you discover a problem, contact your authorized Provider for maintenance and repair.

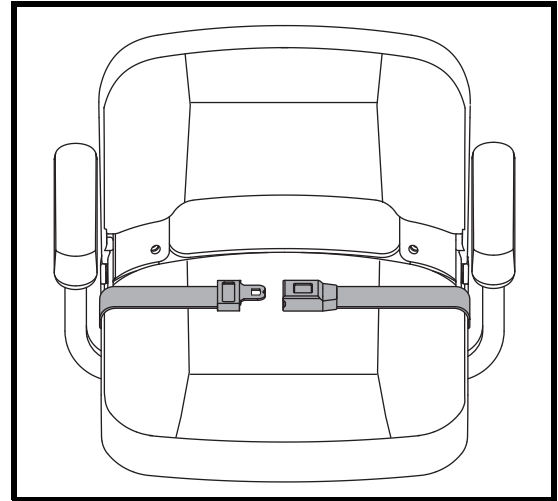

Figure 22. Positioning Belt - Metal Tab Style

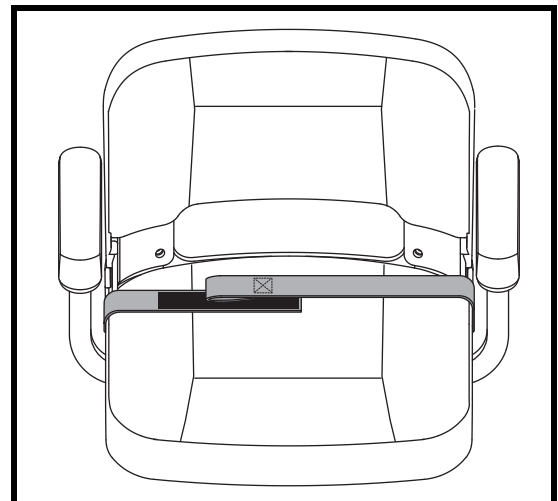

Figure 23. Positioning Belt - Reusable Hook and Loop Fastener Style

VI. DISASSEMBLY AND ASSEMBLY

DISASSEMBLY

You can disassemble the Travel Scooter into several pieces. See **figure 24**. No tools are required to disassemble or assemble your Travel Scooter. Always disassemble or assemble your Travel Scooter on a level, dry surface with sufficient room for you to work and move around—about 5 feet (1.5 meters) in all directions. Remember that some Travel Scooter components are heavy and you may need assistance when lifting them.



WARNING! Do not lift weight beyond your physical capability. Ask for assistance when necessary while disassembling or assembling your Travel Scooter.

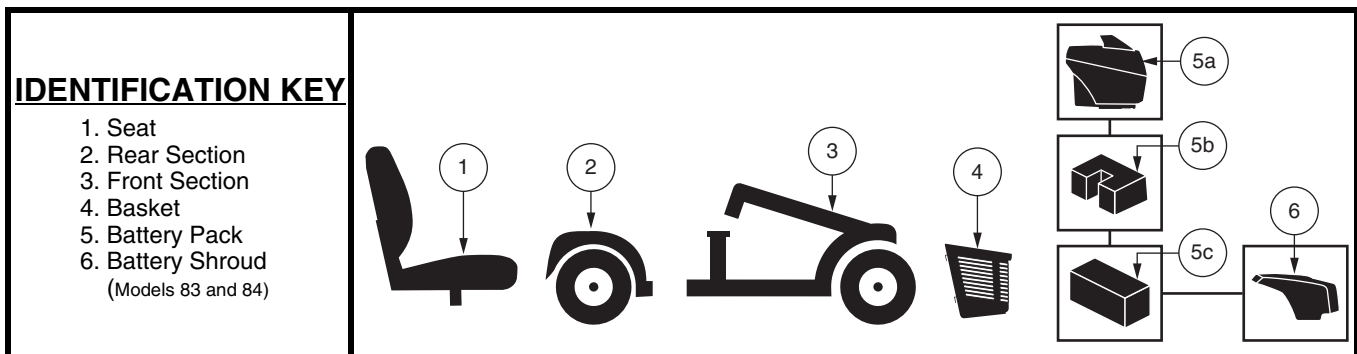

Figure 24. Disassembled Travel Scooter

Disassembly Procedures - Models 36, 83, and 84

1. Remove the key from the key switch.
2. Lock the tiller in the straight ahead position by pushing the tiller lock knob in and turning it clockwise 90°. See **figure 25**. The front wheel must face forward in order to lock the tiller.
3. Remove the seat by lifting it straight up and off of the Travel Scooter. If you encounter resistance when removing the seat, disengage the seat rotation lever and swivel the seat back and forth while lifting up on the seat.
4. Remove the rear shroud by lifting it straight up and off of the Travel Scooter. (Models 83/84 only).
5. Disconnect the battery harness. See **figure 16**.
6. Disconnect the front-to-rear harness. See **figure 16**.
7. Disconnect the battery tie-down strap. (Models 83/84 only). See **figure 16**.
8. Remove the battery pack from the Travel Scooter by lifting it straight up and off of the Travel Scooter.

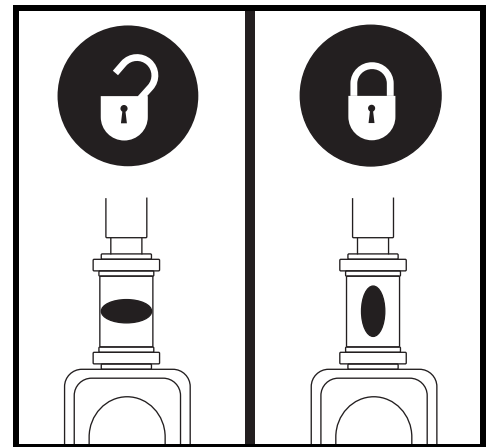

Figure 25. Tiller Lock Knob

Disassembly Procedures - Models 40X, 44X, 40E, 44E, 40LX, 44LX, 50LX, 54LX, 53, 53HD, 54, 54HD, 73, and 74

1. Remove the key from the key switch and then lock the tiller in the straight ahead position by pushing the tiller lock knob in and turning it clockwise 90°. See **figure 25**. The front wheel must face forward in order to lock the tiller.
2. Remove the seat by lifting it straight up and off of the Travel Scooter. If you encounter resistance when removing the seat, disengage the seat rotation lever and swivel the seat back and forth while lifting up on the seat.
3. Remove the battery pack by lifting the pack straight up and off of the Travel Scooter.

VI. DISASSEMBLY AND ASSEMBLY

NOTE: Please check the Travel Scooter Features Table on the inside of the front cover to determine if your Travel Scooter has a frame release lever or a lock-up pin before attempting to separate the frame.

Frame Separation

1. With the seat and battery pack removed (see Disassembly Procedures on previous page), lower the tiller and tighten the tiller adjustment knob. See figure 17.
2. Remove the frame lock-up pin. (Models 36, 83, and 84 only)
3. Lift up on the frame release lever, (**OR, lift the seat post for models 36, 83, and 84**) and pivot the rear section backwards, until the frame hooks are no longer resting on the lower frame tube.
4. Slowly separate the two sections of the Travel Scooter. See figure 26.

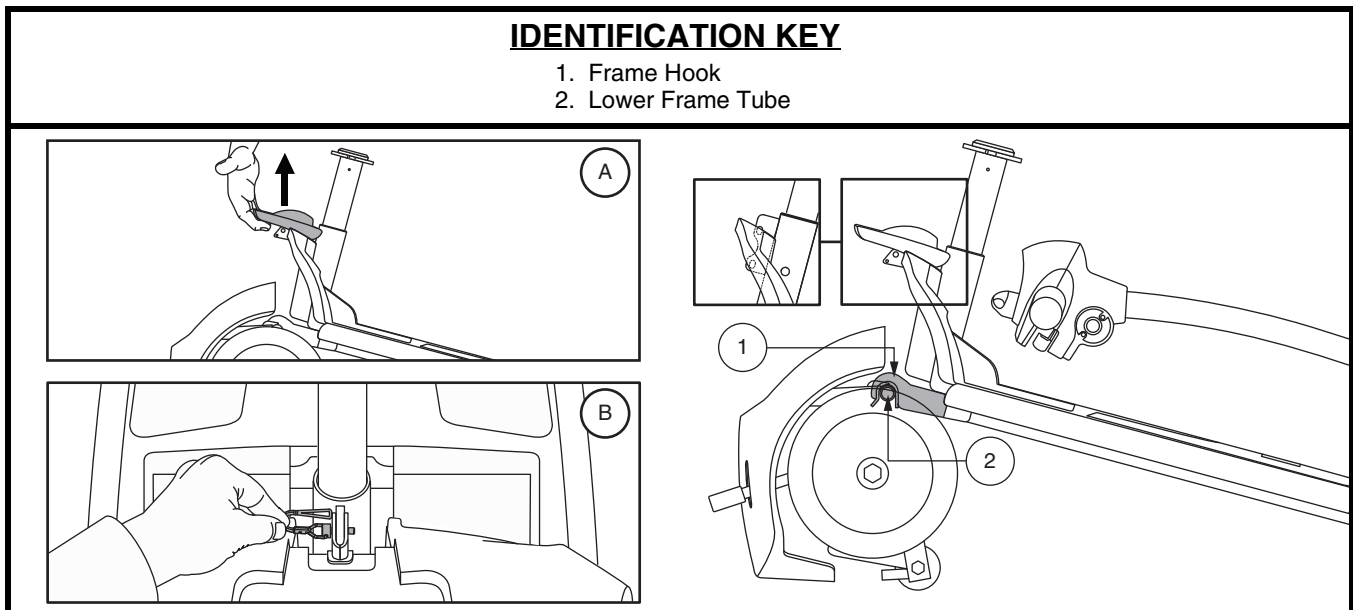

Figure 26. Frame Release Lever (Style A) and Frame Release Lock-up Pin (Style B)

ASSEMBLY

NOTE: Before attempting assembly, tilt the rear half of the Travel Scooter slightly back on the anti-tip wheels as shown in figure 26.

1. Use the frame release lever (or the seat post for models 36, 83, and 84 only) to lift the front section as you align the frame hooks of the front section with the lower frame tube of the rear section. See figure 26.
2. Once the frame hooks are over the lower frame tube, lower the front section and pivot the rear section simultaneously. This will engage the frame lock-up automatically for models 40X, 44X, 40E, 44E, 40LX, 44LX, 50LX, 54LX, 53, 53HD, 54, 54HD, 73, and 74. For models 36, 83, and 84, you will also need to reinstall the frame lockup pin to complete the body assembly. See figure 26.
3. Raise the tiller and fully tighten the tiller adjustment knob. See figure 17.
4. Reinstall the battery pack. For models 36, 83, and 84, make sure to reconnect the battery and front-to-rear harnesses.
5. Reinstall the seat and rotate it until it is secured into place.
6. Unlock the tiller by turning the tiller lock knob 90° counterclockwise. See figure 25.



WARNING! After assembly, make absolutely certain the tiller lock knob is in the unlocked position before riding your Travel Scooter.

VII. BASIC TROUBLESHOOTING

Any electromechanical device occasionally requires some troubleshooting. However, most of the problems that may arise can usually be solved with a bit of thought and common sense. Many of these problems occur because the batteries are not fully charged or because the batteries are worn down and can no longer hold a charge.

DIAGNOSTIC BEEP CODES

The diagnostic beep codes for your Travel Scooter are designed to help you perform basic troubleshooting quickly and easily. A diagnostic beep code will sound in the event one of the conditions listed below develops. Depending on the model you own, your Travel Scooter will communicate by one of the coding methods as follows:

1. A beep code will begin with a series of fast beeps directly followed by slower beeps which indicates the actual code. The beep code is only beeped once. To repeat the beep code, remove the key, then reinsert it and turn it to the “on” position, **OR**
2. A beep code will identify the condition, pause, then repeat the beep code. The beep code will continue to alert you in this manner until the scooter is turned off.

NOTE: Your Travel Scooter will not run unless the beep code condition is resolved and the Travel Scooter has been turned off, then turned back on.

BEEP CODE	CONDITION	SOLUTION
■ (1)	Battery voltage is too low to operate the Travel Scooter.	Charge batteries as soon as possible.
■ ■ (2)	Battery charge is too low.	Charge batteries.
■ ■ ■ (3)	The Travel Scooter's battery voltage is too high to operate the scooter, or the charger is still connected to the off-board charger port.	Unplug charger and/or turn key off, then back on again. If traveling down a slope, reduce Travel Scooter speed to the minimum setting.
■ ■ ■ ■ (4)	Current limit time out.	Turn the Travel Scooter off for a few minutes, then turn your Travel Scooter back on.
■ ■ ■ ■ ■ (5)	The manual freewheel lever is in the (forward) freewheel position.	Remove the key from the key switch, then push the manual freewheel lever to the drive (rearward) position and restart your Travel Scooter.
■ ■ ■ ■ ■ ■ (6)	Throttle control lever not at center position at start up.	Verify that the batteries are fully charged. If the batteries are fully charged, then return the throttle control lever to center position, turn Travel Scooter off then back on.
■ ■ ■ ■ ■ ■ ■ (7)	Speed pot error.	Contact your authorized Provider for assistance.
■ ■ ■ ■ ■ ■ ■ ■ (8)	Motor volts error.	Contact your authorized Provider for assistance.
■ ■ ■ ■ ■ ■ ■ ■ ■ (9)	Other internal errors.	Contact your authorized Provider for assistance.

What if my Travel Scooter does not move when I press the throttle control lever?

- When the manual freewheel lever is pushed forward, the brakes are disengaged and all power to the motor/transaxle assembly is cut.
- Pull back on the manual freewheel lever, turn the Travel Scooter off, and then back on to return to normal operation.

VII. BASIC TROUBLESHOOTING

What if all the systems on my Travel Scooter seem to be “dead”?

- Make certain that the key is in the “on” position.
- Check that the batteries are fully charged.
- Push in the main circuit breaker reset button. See II. “Your Travel Scooter.”
- Make certain that the battery pack is seated properly.
- Make certain that the battery and front-to-rear harnesses are connected properly. (Models 36, 83, and 84 only)
- Be sure the power down timer feature has not been activated. See IV. “Operation.”
- Check the tiller console fuse located under the battery pack.

To check a fuse:

1. Remove the fuse by pulling it out of its slot.
2. Examine the fuse to be sure it is blown. See **figure 27**.
3. Insert a new fuse of the proper rating.



WARNING! The replacement fuse must exactly match the rating of the old fuse. Failure to use properly rated and approved fuses may cause damage to the electrical system.

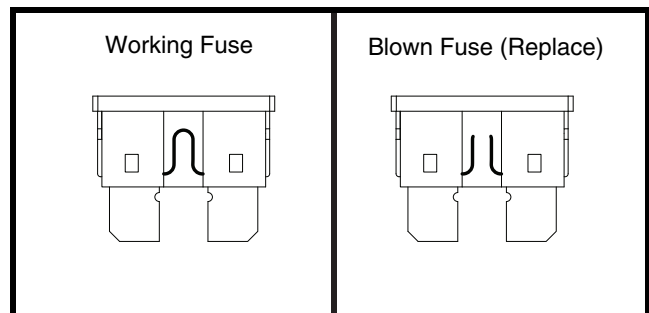

Figure 27. Fuse Replacement

What if the Travel Scooter’s batteries won’t charge?

- Check the fuse located on the battery pack or the console. Replace if necessary.
- During the charging process, if the charger LEDs never indicate a full charge, check the fuse located on the battery pack or the console. Replace if necessary, or have your authorized Provider or qualified technician check and/or replace the fuse.
- Ensure both ends of the charger power cord are connectly properly.
- If the battery pack fuse continually blows, contact your authorized Provider for service.

What if the main circuit breaker repeatedly trips?

- If the main circuit breaker trips repeatedly, see your authorized Provider for service.
- Charge the Travel Scooter’s batteries more frequently. See III. “Batteries and Charging.”
- If the problem continues, have both of your Travel Scooter’s batteries load tested by your authorized Provider.
- You may also perform the load test yourself. Battery load testers are available at most automotive parts stores.
- Follow the directions supplied with the load tester.
- See III. “Batteries and Charging” or “Product Specifications Sheet” for information about your Travel Scooter’s battery type.

What if the battery condition meter dips way down and the motor surges or hesitates when I press the throttle control lever?

- Fully charge your Travel Scooter’s batteries. See III. “Batteries and Charging.”
- Have your authorized Provider load test each battery.
- Or, see the previous troubleshooting question for load testing the batteries yourself.

If you experience any problems with your Travel Scooter that you are not able to solve, immediately contact your authorized Provider for information, maintenance, and service.

VIII. CARE AND MAINTENANCE

Your Travel Scooter requires a minimal amount of care and maintenance. If you do not feel confident in your ability to perform the maintenance listed below, you may schedule inspection and maintenance at your authorized Provider. The following areas require periodic inspection and/or care and maintenance.

TIRES

Regularly inspect your Travel Scooter's tires for signs of damage or wear.

WHEEL REPLACEMENT

Your Travel Scooter is equipped with solid tire inserts. If you have a damaged or worn tire, the entire wheel must be replaced. Contact your authorized Provider for information regarding replacement wheels for your Travel Scooter.



WARNING! Wheels on your Travel Scooter should only be serviced/replaced by a qualified technician.

WARNING! Be sure that the key is removed from the key switch and the scooter is not in freewheel mode before performing this procedure.

Follow these easy steps for a quick and safe repair for solid tires:

1. Remove the key from the key switch and ensure your Travel Scooter is not in freewheel mode.
2. Elevate the side of the Travel Scooter of which you are removing the tire. Place wooden blocks under the frame to elevate the Travel Scooter.
3. Remove the drive wheel nut and washer from the axle. **See figure 28.**
4. Pull the wheel off the axle.
5. Slide the new wheel onto the axle. Make sure the the axle key is in the axle slot.



WARNING! Ensure that the axle key is properly installed into the axle slot when mounting the wheel. If not installed securely, the braking system is disengaged which may cause personal injury and/or product damage may result.

6. Reinstall the washer and drive wheel nut onto the axle and tighten.



WARNING! Make sure that both the nut and washer are reinstalled and tightened properly.

7. Remove the blocks from beneath the Travel Scooter.

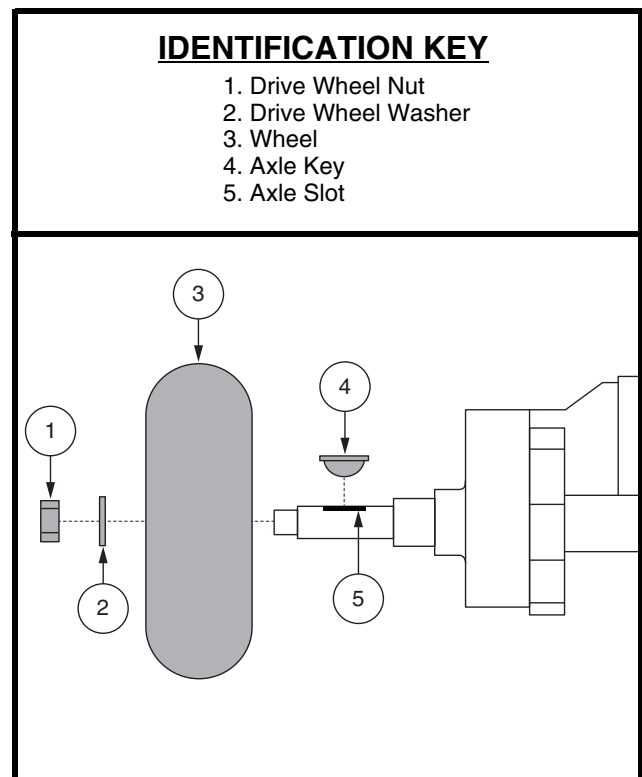

Figure 28. Wheel Replacement

VIII. CARE AND MAINTENANCE

EXTERIOR SURFACES

Bumpers, tires, and trim can benefit from an occasional application of a rubber or vinyl conditioner.



WARNING! Do not use a rubber or vinyl conditioner on the Travel Scooter's vinyl seat or tire tread. They will become dangerously slippery.

CLEANING AND DISINFECTION

- Use a damp cloth and mild, non-abrasive cleanser to clean the plastic and metal parts of your Travel Scooter. Avoid using products that may scratch the surface of your Travel Scooter.
- If necessary, clean your product with an approved disinfectant. Make sure the disinfectant is safe for use on your product before application.



WARNING! Follow all safety instructions for the proper use of the disinfectant and/or cleaning agent before applying it to your product. Failure to comply may result in skin irritation or premature deterioration of upholstery and/or Travel Scooter finishes.

BATTERY TERMINAL CONNECTIONS

Make certain that the terminal connections remain tight and are not corroded.

WIRING HARNESSSES

- Regularly check all wiring connections.
- Regularly check all wiring insulation, including the charger power cord, for wear or damage.
- Have your authorized Provider repair or replace any damaged connector, connection, or insulation that you find before using your Travel Scooter again.



PROHIBITED! Even though the Travel Scooter has passed the necessary testing requirements for ingress of liquids, you should keep electrical connections away from sources of dampness, including direct exposure to water or bodily fluids and incontinence. Check electrical components frequently for signs of corrosion and replace as necessary.



WARNING! Do not pull on electrical harnesses directly to detach them from the scooter. Always grasp the connector itself when disconnecting the harness to prevent wire damage.

ABS PLASTIC SHROUDS

The shroud pieces are formed from durable plastic and may be coated with an advanced formula urethane paint. A light application of car wax will help the shrouds retain their high gloss.

AXLE BEARINGS AND THE MOTOR/TRANSAXLE ASSEMBLY

These items are all prelubricated, sealed, and require no subsequent lubrication.

MOTOR BRUSHES

The motor brushes are housed inside of the motor/transaxle assembly. They should be inspected periodically for wear by your authorized Provider.

CONSOLE, CHARGER AND REAR ELECTRONICS

- Keep these areas free of moisture.
- Allow these areas to dry thoroughly if they have been exposed to moisture before operating your Travel Scooter again.

VIII. CARE AND MAINTENANCE

NYLON LOCK NUT REPLACEMENT

Any nylon insert lock nut removed during the periodic maintenance, assembly, or disassembly of the Travel Scooter must be replaced with a new nut. Nylon insert lock nuts should not be reused as it may cause damage to the nylon insert, resulting in a less secure fit. Replacement nylon insert lock nuts are available at local hardware stores or through your authorized Provider.

STORING YOUR TRAVEL SCOOTER

If you plan on not using your Travel Scooter for an extended period of time, it is best to:

- Fully charge its batteries prior to storage.
- Remove the battery pack from the Travel Scooter.
- Store your Travel Scooter in a warm, dry environment.
- Avoid storing your Travel Scooter where it will be exposed to temperature extremes.
- Recommended storage temperature: -104°F/-75°C to 158°F/70°C.

Batteries that are regularly and deeply discharged, infrequently charged, stored in extreme temperatures, or stored without a full charge may be permanently damaged, causing unreliable performance and limited service life. It is recommended that you charge the Travel Scooter batteries periodically throughout periods of prolonged storage to ensure proper performance.



WARNING! Always protect batteries from freezing temperatures and never charge a frozen battery. Charging a frozen battery can result in damage to the battery.

For prolonged storage, you may wish to place several boards under the frame of your Travel Scooter to raise it off of the ground. This takes the weight off the tires and reduces the possibility of flat spots developing on the areas of the tires contacting the ground.

DISPOSAL OF YOUR TRAVEL SCOOTER

Your Travel Scooter must be disposed of according to applicable local and national statutory regulations. Contact your local waste disposal agency or authorized Provider for information on proper disposal of packaging, metal frame components, plastic components, electronics, batteries, neoprene, silicone, and polyurethane materials.

Please fill out the following information for quick reference:

Provider: _____
Address: _____
Phone Number: _____
Purchase Date: _____

* I NFMANU4392 *

--

Product Serial # / Numéro de série