

# Rascal Powerchair Model P200

Owners Manual & Service Record



Model P200

**ELECTRIC MOBILITY** **EURO**

*Rascal*



Rascal P200

Electric Mobility Euro Ltd offers the Rascal P200 Powerchair for convenient indoor and outdoor use. The P200 is a sturdy powerchair providing a comfortable seating position for people with disabilities who need a powerchair that has good range, removable seat cushion, adjustable seat angle, adjustable seat back angle and adjustable armrests. The P200 can be quickly adapted to suit a wide variety of users.

So long as this powerchair is maintained and operated in accordance with this manual it should last for many years, and provide you with freedom and independence.

Please read this manual thoroughly before using this powerchair. If you have any doubts about warnings or instructions, ask your dealer for an explanation. If at any time you feel you may not be able to control the vehicle safely, do not drive, but consult your dealer for a solution.

If you think the powerchair may be damaged, do not drive it but contact your dealer for advice.

We suggest that you keep this manual in a safe place. It contains essential information on the operation of the Powerchair and also includes the maintenance records.

### **Notice**

All Electric Mobility Vehicles are sold through authorised dealers. Make sure your dealer demonstrates all the features of the product prior to, or when, it is delivered.



### **Warning!**

This manual contains important safety notices. Please take time to read and understand them. Ignoring them may endanger you or others.

---

# Contents

Dealer information	4
Features and layout	4
Safety information	5
Intended use	5
Safety information	6
Controls - joystick	8
Controls - driving controls & accelerator	9
Freewheel device	10
Brakes	10
Seat adjustment	11
Joystick controller adjustment	12
Height / width adjustable armrest	12
Swing away footrests	13
Transferring	13
Driving your vehicle	13
Driving your vehicle - hazards	14
Transporting your powerchair	15
Battery charging	15
Battery care	16
User maintenance	16
Servicing & maintenance	17
Additional safety information	17
Engineer's checklist	18
Troubleshooting guide	19
Diagnostic table	20
Frequently asked questions	21
Guarantee & warranty	22
Technical information regarding EMI	22
Technical specification - P200	23
Service log	24
Brochure request	25
Warranty card - dealer information	25

## Dealer Information

**This is your contact number  
for service and support**

Dealer Stamp

Telephone:

Email:

Product Model Number

Serial Number

Date of Purchase

Owner

For product information see serial number plate located on the painted frame beneath the armrest (left side).

### Manufacturer

**ELECTRIC  
MOBILITY EURO**

Electric Mobility Euro Limited

Canal Way, Ilminster, Somerset TA19 9DL

Company Registration in England No. 2419231

## Features and Layout

Photo shows the P200 Powerchair. See the Technical Specification sheet for detailed weights and performance.



---

# Safety Information



**Read this manual thoroughly before driving or operating the vehicle.**

If you have any doubt about the content of this manual phone your dealer to resolve the problem. Please read this manual, and ensure your powerchair is serviced regularly.



Within this manual there are important safety notices. They are clearly marked with the sign (left) Make sure that you understand all these notices. If you have any doubt, contact your dealer.

© 2009 Electric Mobility Euro Ltd.

No liability is assumed with respect to the use of any information contained in this publication. While every precaution has been taken in the preparation of this publication Electric Mobility Euro Ltd. assumes no responsibility for errors or omissions nor is any liability assumed for damages resulting from the use of information contained in this publication. This publication, as well as the operational details described herein, is subject to change without notice.

---

## Intended use of the vehicle

This vehicle is designed for use by adults with a disability (up to the maximum recommended weight – see Technical Specification sheet) who require a robust, adjustable, comfortable powerchair with a good range.

The P200 powerchair is intended for use indoors, for use in shopping precincts and trips on reasonably paved areas. Kerbs should be avoided, but the P200 Powerchair can mount kerbs and small obstacles up to that specified in the Technical Specification.

Users could endanger themselves and others if they are not capable of driving this powerchair safely. Dealers will advise on the most suitable vehicle from the Electric Mobility range, but it is up to users to ensure that they have the manual dexterity to drive the vehicle, adequate sight and hearing to perceive danger in time, and can at all times operate the Powerchair safely in the expected conditions. If in doubt we suggest you consult a healthcare professional or your nearest dealer for advice on the most suitable powerchair for your particular condition. Users should also regularly assess their ability to operate their vehicle safely.

This Powerchair has relatively small front wheels for good manoeuvrability so it should not be used on uneven, potholed or rutted surfaces or slippery grassy areas.



# Safety Information

## General Warnings

**Warning !** The operation of Powerchairs can endanger the life of the driver or third parties. Any driver should **always** be fully capable of operating this vehicle safely.

**Warning !** Sitting for long periods may increase the chance of thromboses or pressure sores. Users prone to such conditions are advised to take medical advice.

**Warning !** These Powerchairs have been designed and tested for drivers up to the maximum user weight recorded in the Technical Specification. This weight should **never** be exceeded.

**Warning !** Do not exceed the specification; do not modify this powerchair or use it other than a powerchair.

**Warning !** Passengers, even children, should never be carried.

**Warning !** Electromagnetic interference may affect the performance of this Powerchair:

- Do not operate devices such as CB radios or mobile phones while the vehicle is switched on.
- Avoid getting close to transmitter masts, such as television and radio stations.

If your vehicle ever starts to operate by itself switch it off and report this to your Dealer.

**Warning !** The operation of any Powerchair may affect sensitive electronic circuits such as alarm systems, garage door closing mechanisms, or automatic doors in shops.

**Driving** Before you drive refer also to “Driving Your Vehicle” ...later in this manual

**Warning ! Freewheel device** Before getting on the Powerchair, always check that both the freewheel levers are in the “Drive” Position on **both** the motors. When the levers are in the freewheel position there is **no** braking and the Powerchair could run down a slope and cause injury or even death. Always apply both the handbrakes when you are at rest.

**NEVER SIT ON THE POWERCHAIR WHEN IN FREEWHEEL UNLESS AN ATTENDANT HAS FIRM CONTROL OF THE POWERCHAIR. NEVER ALLOW AN ATTENDANT TO LEAVE YOU ALONE WHEN YOUR POWERCHAIR IS IN FREEWHEEL, UNLESS BOTH HANDBRAKES HAVE BEEN APPLIED AND THE POWERCHAIR CANNOT MOVE.**

**Warning ! Transferring On and Off** Do not attempt to get on or off your Powerchair unless it is switched off, at rest, , both the handbrakes are applied, and the power chair is on a stable level surface. Never get on and off on a hill.

**Warning ! Damage** Before driving off check the Powerchair for damage, particularly that which might affect the controls, wheels, brakes and drive motors.

**Warning ! Footrest** Before switching on your Powerchair, always put the footrest down and place your feet firmly on it. If you drive forward with your feet still on the ground, your feet could become trapped under the Powerchair and serious injury could result.

**Warning ! Armrests** Do not use armrests as a support when getting in or out of your powerchair. Make sure they are secure before you start off otherwise you might fall out.



---

**Warning ! Seat Belt** It is advisable to use your seatbelt whenever you use your vehicle.

**Warning ! Battery Charge** Before driving off always check the battery indicator. If you are in any doubt, ensure all the batteries are fully charged before starting on a journey.

**Warning ! Castoring** Be aware that, if you set off when the castors are not straight, the initial movement could be sideways.

**Warning ! Power** Unless there is an emergency, do not switch the power off when moving. The Powerchair will stop very suddenly. Centre the joystick and your Powerchair will come to a controlled stop.

**Warning ! Slopes** On steep slopes the Powerchair could topple over. Always try to avoid crossing a slope. If you have to cross a slope, take great care to avoid tipping. Never make sharp turns on slopes. Never drive on slippery or icy slopes. Never back down a slope as your Powerchair could tip over backwards. Ensure that the backrest is upright before tackling a slope or kerb. If you are not comfortable with the hill gradient, consider an alternative route. See Driving Your Vehicle – Hazards for more advice.

**Warning ! Kerbs** You should try to avoid driving up or down kerbs as this may cause the Powerchair to topple. Use access ramps wherever possible. **Never** attempt kerbs greater than that in the Technical Specification. If you have to climb or descend a low kerb, always tackle it straight on. Lean forward when climbing a kerb and back when descending a kerb. See Driving Your Vehicle – Hazards for more advice.

**Warning ! Speed** Turning at maximum speed might cause the Powerchair to topple over. Always slow down for turns. Always slow down when amongst pedestrians and ensure you do not run into them.

**Warning ! Stopping** If the Powerchair stops suddenly when turning, the Powerchair might topple. Take care when turning.

**Warning ! Leaning Over** Do not lean sideways, as this could cause the Powerchair to topple.

**Warning ! Escalators** Never drive this Powerchair onto an escalator as this could result in severe injury.

**Warning ! Driving in poor visibility** Powerchairs are not easily seen. Consider wearing a high visibility jacket to warn others of your presence. Avoid using your P200 Powerchair in poor visibility.

**Warning ! Roads** Powerchairs are not for use on roads, apart from crossing roads at designated places.

**Warning ! If the vehicle is left out in the sun,** surfaces could become extremely hot. Always try to park the vehicle in the shade.

**Warning !** This vehicle is not suitable for use as a seat for an occupant when in a motor vehicle.



## Controls - Joystick Assembly

Before driving your vehicle it is important to familiarise yourself with the controls. Do not attempt to drive the vehicle before reading the rest of this Handbook.

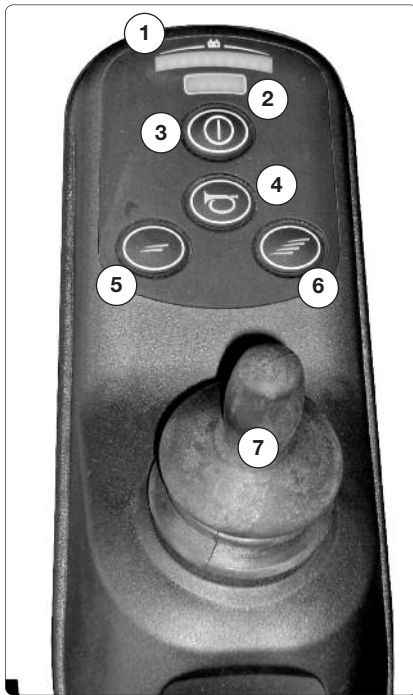

### Description of controls

- 1. Battery Indicator:** These lights show the level of charge in the batteries. When in the green lights show the batteries are fully charged. When in the yellow and red lights show the batteries need recharging and when only the red lights show the batteries **urgently** need recharging. Note: When the vehicle is climbing an incline or starting off, the level may drop momentarily; this is normal.
- 2. Maximum Speed Indicator:** This shows what speed setting has been selected by the controls 5 and 6. The more lights that show, the higher the maximum speed. It is advisable to set the maximum speed at the slowest setting until you are familiar with controlling your P200 Powerchair.
- 3. Power On Off Button:** Switch the power on and off using the power button. Remember to switch off **when not in use**. Do not leave the ignition on when not in use, especially when charging the vehicle. Note that this switch can also be used to “lock” the Powerchair to prevent it being used, or stolen. (see unlocking and locking page 9)
- 4. Horn:** Press the button and the horn will sound. Release and the horn will cease.
- 5/6. Speed Controls:** These controls enable you to increase or decrease the top speed of your Powerchair. When the speed increase button (6) is pressed the maximum speed the powerchair can achieve is increased; when the decrease button (5) is pressed the maximum achievable speed is reduced. The speed indicator shows a number of lamps to indicate the maximum speed set. Set the maximum speed to low until you are confident of driving your Powerchair safely. Do not adjust the speed when the vehicle is moving, but reset it when you are stationary. If you become alarmed at your speed release the joystick and the vehicle will slow down immediately.
- 7. Joystick:** The more you move the joystick forward, the faster you will go forwards. Move the joystick back and you will go back. Move the joystick to the right and you will turn to the right; move it to the left and you will turn left.

**Charging Point:** The charging point is situated beneath the joystick controller at the front.





---

# Controls - Driving Controls/Accelerator

## **Joystick control - To operate, turn on the power.**

Firstly make sure your wrist is supported on the armrests. If it is not supported, a jolt may cause a movement of the joystick and an involuntary change in direction of speed. Find an open level area with no obstructions to practice controlling the vehicle until you are confident that you can drive safely. Note. The controls can be changed to the other arm for customers with a left-hand bias. Please contact your local dealer for information.

**Going Forward or Backwards:** Gently push the joystick away from you and your Powerchair will move forward, pull it backwards and it will move backwards. Release pressure on the stick and the vehicle will stop. The further you move the stick the faster you will go.

**Turning Left or Right:** Push the joystick to the right and your Powerchair will move right, move the joystick to the left and the Powerchair will go left. Practice turning while in gentle forward motion to familiarise yourself with driving the vehicle.

**Braking:** Whenever the joystick is in the central position, the automatic brake will operate. Practice stopping on level ground to ensure that you know how quickly you can expect your Powerchair will come to a stop.

**Sleep Mode:** With the power on, If you do not operate the joystick for a while, then the controller will go into "sleep mode" to preserve the batteries. Any button press or joystick movement will re-activate the controller and you can then drive normally.

**Joystick Disabling during Start-Up:** To prevent sudden unexpected movements, the joystick is disabled during start-up. If the joystick is operated when the power button is pressed, the lamps will flash slowly. By centring the joystick this indication will stop and the joystick will operate normally.

**Note:** The controller has a diagnostic mode. The lamps will flash to indicate that the controller has detected an error or fault. If this happens refer to the diagnostic table at the back of this manual, unless it is simply the result of the joystick not being central at start up, which can be cleared as above.

**Locking Your Vehicle for Security.** This powerchair controller is equipped with a keyless lock feature which can be used to restrict use by unauthorised individuals.

### **To Lock**

- Turn 'ON' power (depress and release power button).
- Depress and hold the power button. After a second the controller will beep. Release the power button after the beep.
- Push the joystick forward until the controller beeps.
- Pull the joystick backward until the controller beeps.
- Release the joystick (there will now be a long beep - the powerchair is now locked).

### **To Unlock**

- Turn 'ON' power (depress and release the power button).
- Push the joystick forward until the controller beeps.
- Pull the joystick backward until the controller beeps.
- Release the joystick (there will now be a long beep - the powerchair is now unlocked).

Ask your dealer to demonstrate all these functions and make sure you can operate all the modes of the controller before you take your vehicle home.



## Freewheel Device

When the vehicle is switched off the brakes are automatically engaged. This is called “Failsafe Braking”. Also, if the batteries are flat, the brakes are applied. There may be occasions where you may wish to move the vehicle without power. To do this there is a freewheel device fitted on each motor. The freewheel device allows the vehicle to be pushed without power. To activate, first locate the levers on the end of each drive motor. - see Illustration.

- Make sure the ignition is switched **off**.
- Move **both** the levers into the freewheel position. The vehicle can now be pushed in freewheel. Note that if the levers are too stiff to move a small movement of the chair back or forward will make it easier to operate the levers. Get your dealer to show you.
- Move both the levers to engage drive. The vehicle is now braked. This is the normal operating position.

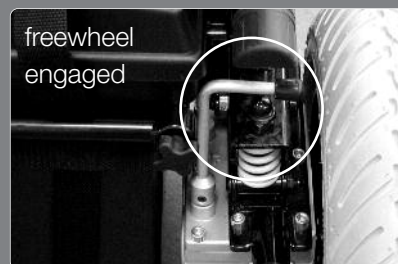

### **IF YOU ARE NOT COMPLETELY SURE OF THIS FEATURE CONTACT YOUR DEALER BEFORE OPERATING THE POWERCHAIR.**

- Push the lever **DOWN** and rotate sideways towards the drive wheel to enable the vehicle to be moved without power. Braking is disabled. **NEVER** sit on the vehicle with the lever in this position.
- Rotate the lever to the **DRIVE ENGAGED** position This is the normal operating position. The brakes are enabled, and the vehicle can only operate with the lever in this position.

**NEVER SIT ON THE POWERCHAIR WHEN IN FREEWHEEL UNLESS AN ATTENDANT HAS FIRM CONTROL OF THE POWERCHAIR. NEVER ALLOW AN ATTENDANT TO LEAVE YOU ALONE WHEN YOUR POWERCHAIR IS IN FREEWHEEL, UNLESS BOTH HANDBRAKES HAVE BEEN APPLIED AND THE POWERCHAIR CANNOT MOVE.**

## Brakes

The P200 Powerchair is fitted with an automatic braking system which is applied when the joystick is in the central position. Release the joystick and the Powerchair will slow to a stop. When the Powerchair stops an automatic brake will



engage. This will stop the vehicle rolling forwards or backwards. When you start, this brake will automatically disengage. If the battery should go flat this brake automatically engages. The P200 is also fitted with a handbrake on each of the the rear wheels. Push the lever forward to engage each brake. Never leave the powerchair in freewheel without engaging **both** brakes. Both brakes should be engaged before you get on or off the powerchair.



**Warning!** If the freewheel devices are in “freewheel” the braking is disabled. Never select the freewheel devices if the Powerchair is on a slope or could be pushed onto a slope.

**Never** leave one motor in Drive and the other in freewheel. You could damage your Powerchair or cause injury. Never leave one handbrake engaged and the other off; this could cause a sudden turn on starting

# Seat Adjustment

If you need help with any of these adjustments ask your dealer to assist you.

## Seat Angle Adjustment (1)

The seat angle is adjustable to four different positions

- Seat vertical 90°
- Seat reclined by 3.5° to 93.5°
- Seat reclined by 7° to 97°
- Seat reclined by 10.5° to 100.5°

## Adjusting the seat angle (2)

- Loosen the thumbscrew.
- Adjust bracket to desired position.
- Tighten the thumbscrew to lock the seat in place. Be sure the screw is firmly tightened.

## Backrest Angle Adjustment (3)

The backrest angle is adjustable to seven different positions

- Vertical - 90° - upright position for driving outdoors
- Reclined 5° to 95°
- Reclined 10° to 100°
- Reclined 15° to 105°
- Reclined 20° to 110°
- Reclined 25° to 115°
- Reclined 30° to 120°

For reasons of operator forward visibility and vehicle stability, it is suggested that the most upright back angle be chosen that is consistent with operator comfort.

## Resetting the Back Angle (4)

- Note that at the pivot point of the seat back, a screw is positioned through the pivot that limits backward motion of the seat back. Both pivots are imprinted with the stop angles. Observe the current stop position.
- Remove the nut washer and screw from the stop position of each pivot using the allen key and spanner provided.
- If you need to recline the back more, reposition the stop screws into stop positions 1 higher than was observed in the first step. If you wish to reduce the back angle, reposition the stop screws into positions 1 lower than observed in the first step.
- Replace the nuts and washers onto the stop screws to lock the setting.

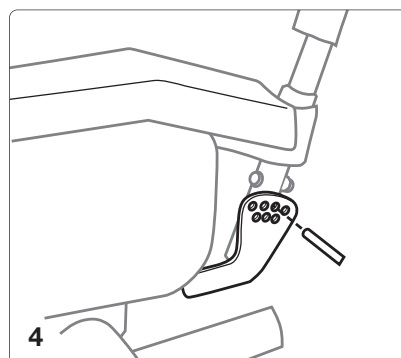
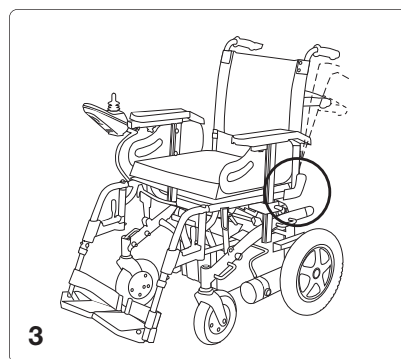
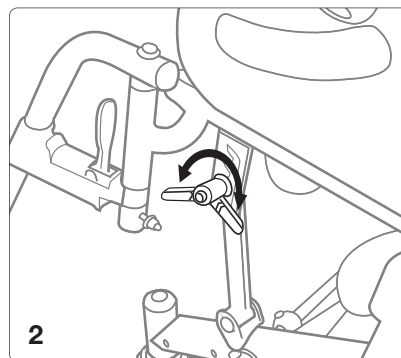
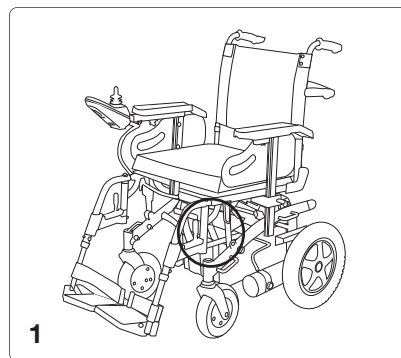

**Warning!** Do **not** use the armrest as a support when getting in and out of your Powerchair – Armrests are not designed to fully support your weight.

**Warning!** Reclining angles in excess of 100° are only for use when the chair is stationary, on a flat surface with the power off.

**Warning!** Always return the seat to the upright or 95° position before starting off. If the seat back is tilted too far back, tipping over backwards is more likely, especially if travelling up ramps, kerbs or hills.



## Joystick Controller Adjustment

The joystick controller position can be adjusted by

- Loosening the thumbscrew.
- Sliding the joystick tube in or out to the most comfortable position.
- Re-tighten the thumbscrew and ensure that the controller is secure.

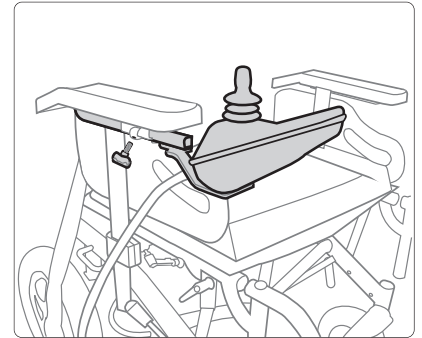
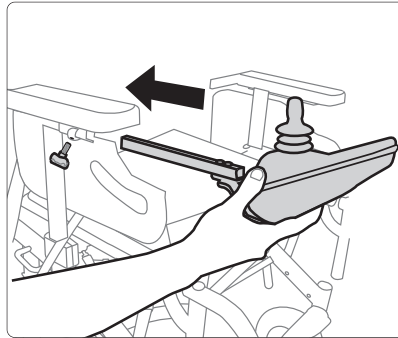

The joystick can be positioned along side the armrest by holding onto the body of the controller and gently moving it outwards. The controller will swing round to any position you find most comfortable for driving. The controller will then be outside the armrest; be careful not to impact the controller when manoeuvring.

Ask your dealer if you wish to have the joystick on the left hand armrest and they will make this change for you. Alternatively ask them to explain how this can be done.



## Height and Width Adjustable Armrests

### Setting the Armrest height (1)

- Locate the lever retaining the armrest
- Loosen the lever
- Pull the armrest up or down to select the most comfortable height
- Tighten the lever and ensure that the armrest is secure

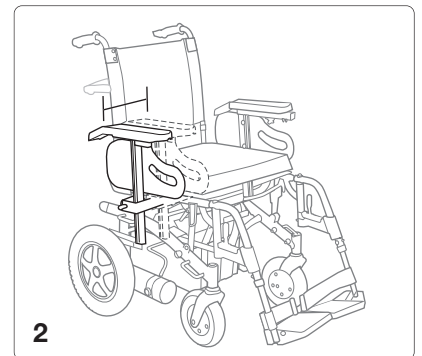
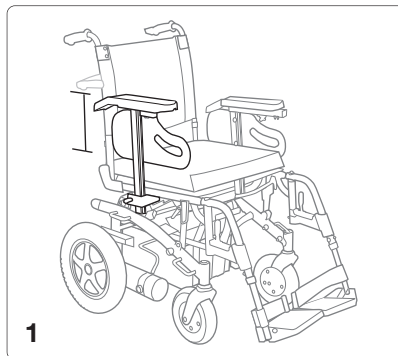

It may be better to have someone else adjusting height while you are sitting in the chair and making sure the armrests are in a comfortable position before they are locked in place.

### Setting the Armrest width (2)

- Locate the knob below the seat retaining the armrest
- Loosen the lever
- Pull the armrest in or out to select the width required
- Repeat with the other armrest
- Tighten the levers making sure that the armrests are equidistant from the centre of the seat and ensure that both armrests are secure.



**Warning!** Always check the knobs and levers are tight before driving the Powerchair

**Warning!** Do not use the armrest as a support when getting in and out of your Powerchair  
Armrests are not designed to fully support your weight.

---

## Swing Away Footrest

- Press the plastic lever to release the locking mechanism. This allows either;
  1. The footrest to be lifted out or,
  2. The footrest to swing left or right.To return the footrest to the standard seating position, reverse this process.

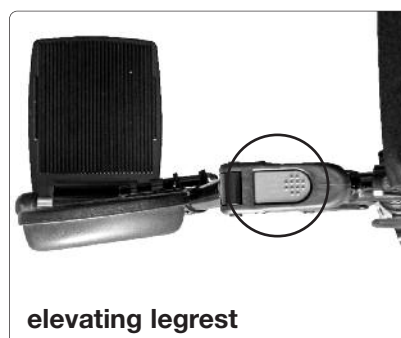
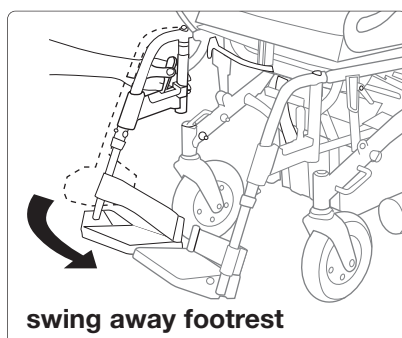

### Elevating Legrest (optional)

The P200 powerchair has optional elevating legrests. When fitted these can be used to support your lower leg. To adjust the legrest angle, press the top of the footrest attachment (see photo) to achieve desired angle. When you want to get out of the powerchair, press the top of the footrest attachment (see photo) and the footrests will lower to the driving position. You should not normally drive with your legs in the elevated position.

---

## Transferring In And Out Of Your Powerchair

### Transferring into your Powerchair

- Make sure your powerchair is stable on a level surface, both the handbrakes are applied and it is not in freewheel.
- Try and push the powerchair before getting in, to make sure the brakes are engaged.
- Ensure that the controller is turned off before you try and get into your powerchair.
- We recommend moving the footrest to the vertical position.
- With your back to the chair, steady yourself with the armrests and lower yourself gently into the seat; do not put undue weight onto the armrests !
- Before moving off disengage **both** handbrakes.

### Getting out of your Powerchair

When getting out make sure your powerchair is on a level surface and the powerchair is not in freewheel.

- Engage both handbrakes.
- Switch the controller power off before you try to get out.
- Raise the footrests to the vertical position.
- Place your feet between the legrests and
- Raise yourself gently into a standing position using the armrests to steady yourself.

If you feel at all uncertain about getting out, seek assistance before you try!

---

## Driving Your Vehicle

**Warning!** Whether or not this is your first mobility vehicle, please read these guidelines as all vehicles differ. Failure to do this may cause damage to you, a third party or the vehicle.



1. **Before you set out**, do check the weather forecast. We suggest that you make sure you are wearing suitable clothing, whether your journey is long or short.
  2. **If you are taking medication** check with your doctor or physician that your ability to control the vehicle will not be impaired and do not drink alcohol and drive.
  3. **Only use the vehicle for the purpose its intended for.** Do not drive through water or on slippery surfaces; do not transport more than one person; do not tow other vehicles or carry excess weight.
-



- 
4. **Before sitting in your Powerchair**, check both the freewheel levers are **not** in the freewheel position
  5. **Check the battery charger is disconnected.**
  6. **Check the backrest is upright**
  7. **Ensure your feet are securely on the footrests.**
  8. **Check you have adjusted the seat** as instructed in this manual – get comfortable. Secure your seat belt.
  9. **Make sure the way ahead is clear.**
  10. **Disengage both handbrakes** by firmly moving them back onto the "Brake Off" position.
  11. **Switch on the power.** Check the battery level indicator is in the green area.
  12. **Speed Control.** Set the speed control to a low setting.
  13. **Gently push the joystick in the direction** you wish to go. The vehicle will now move off. The further you push the joystick the faster the vehicle will go.
  14. **To brake, return the joystick to the neutral position.** If you become unsure or feel unsafe release the joystick immediately.
  15. **As you get accustomed to the power** you can increase the speed.
  16. **Switch off when not in use.** To conserve your batteries and prevent the vehicle accidentally moving, always turn off the power when your Powerchair is not in use.
- 

## Driving Your Vehicle – Hazards

Before driving the Powerchair you should be aware that, under certain circumstances it could become unstable and tip over. Your Powerchair has been designed to operate on paved, even surfaces and should not be used on rough, rutted, soft or slippery terrain.

**Getting in and out of the vehicle:** When getting in make sure that the vehicle is on level ground, both handbrakes are engaged, and not in freewheel mode. Ensure that the armrests are secure. When getting out, park on level, stable ground, switch off the Powerchair and engage both handbrakes before leaving your seat. Make sure you get out of the vehicle in a safe area.

**Seat Back Position:** Always drive with the seat back in an upright position.

**Kerbs and Obstacles:** Always try to avoid kerbs and obstacles. Never ride up or down kerbs or obstructions higher than that in the Technical Specification Sheets. Always tackle obstacles head on. Never drive or turn across a slope. Note that the anti-tip rollers at the rear of the Powerchair may contact the kerb as you descend; this is normal.

**Hills & Slopes: Going Up Hill. Lean slightly forward when going up.** Remember that the seat back should be in the upright position. Make sure you have enough speed to climb the slope. **Do not stop or turn the vehicle around.** If you have to turn while climbing an incline, keep going until you reach a level area. If you have to start on an incline, lean forward and apply power slowly – do not start and stop. If you are not comfortable about tackling a gradient, consider an alternative route. Note: Always check that the battery level is high; going up hill takes a lot of energy. If the level drops too low the vehicle will cut out leaving you stranded.

**Hills & Slopes: Going Down Hill. Lean back in the seat when going down,** Turn the speed control dial to low. If you are not comfortable about tackling a gradient, consider an alternative route.

**Try to avoid crossing slopes – always try to drive straight up and down the slope NEVER BACK DOWN A SLOPE!**

**Turning:** Always **slow down** before a turn; turning at speed can cause the powerchair to topple. Look in the direction you are travelling – If there is a blind corner sound the horn.

**Turning Circle:** So you can judge the turning circle, practice manoeuvring your powerchair. This is important to avoid tipping off kerbs, and when going into and out of lifts or entrances.

**Bad Weather:** If it is snowing or icy stay at home! Remember that ice, snow and slippery surfaces such as manhole covers, wet grass and drains could affect braking and steering. Use caution at all times.

---

**Shower Rooms or Washing:** Never take your powerchair into a shower or steam room, and never hose it down. Its sensitive electronics could malfunction if they get wet or damp.

**Tyres:** Your vehicle is fitted with solid tyres that will not puncture. Should they become damaged they should be replaced by your dealer. It is important that they are not worn to ensure the handbrakes work effectively. Do not attempt to replace them yourself.

---

## Transporting your Powerchair

Contact your dealer for advice on how best to transport your powerchair in your vehicle. You may prefer to use ramps rather than lifting the components. By removing the two pins at the base of the seat back it is possible to fold the back flat for transportation.

**Warning!** Transporting the Powerchair involves lifting and handling heavy parts. Weights are given in the Technical Specification; consider if you need help in handling parts before you try to lift them. The P200 can be transported in Estate cars and MPVs using ramps. Contact your dealer for advice on how best to transport your Powerchair in your vehicle, they can provide and demonstrate the use of suitable ramps.



**Warning!** Pinching or Crushing. Be careful to avoid being pinched or having your hands crushed when lifting or handling parts. Wear gloves whenever possible.

**Warning!** Only use ramps to position the Powerchair into the back of a vehicle. Do not try to lift your Powerchair - back injury may result!

---

## Battery Charging

**Warning!** When charging batteries **NEVER** smoke, or charge batteries in a place where there are naked flames such as gas-fired heaters as, under exceptional circumstances, batteries may give off gases that could ignite and explode. Always make sure that battery box is not damaged.



**Warning!** When charging batteries **NEVER** connect or disconnect the charger while it is still connected to the mains.

The charging socket is located underneath the Joystick controller. When the vehicle is charged remove the plug. The battery charger has a red indicating lamp. When the charger is connected and switched on at the mains the lamp will show red. The second light shows

- Yellow when charging
- Green shows full charge
- Off to indicate OK to disconnect the charger

Always ensure that the lamp goes out before switching off and disconnecting the charger at the mains.

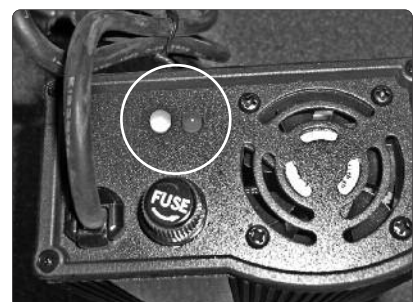



---

## Connection Instructions

When you receive your Powerchair the batteries are only partially charged - always fully charge them overnight before use.

1. **Place you machine in an area that is dry and well ventilated.** Make sure a power point is nearby.
  2. **Check the vehicle is switched off.**
  3. **Check the mains switch is off.** Never connect or disconnect the charger with the mains on.
  4. **Connect the charger to the charging point as above.**
  5. **Connect the mains plug and switch on the charger.** Check the power light shows red.
  6. **The charger lamp shows yellow** when charging and then changes to green when the battery is fully charged.
  7. **Wait until the charging lamp goes out then,**
  8. **Switch off the mains and remove the charging plug from the joystick.** Do not leave the charger plugged in with the power off. This will gradually discharge your battery.
- 

## Battery Care

The batteries are the lifeblood of your vehicle. Their characteristics can change depending on charging, temperature, usage and other factors. Listed below are guidelines to prolong battery life.

- After using your vehicle always charge it at the end of the day - even after a short journey.
- If you do not use your vehicle for a prolonged period, place it on charge once a week, overnight.
- Always use the correct charger with the correct batteries.
- If the batteries have been flat for a long time (about 2 months) it is recommended you contact your dealer before charging:
- Do not charge the vehicle in the open – it may rain and the battery charger is not waterproof.
- Keep the vehicle in a well-ventilated area and away from any naked flame.
- Do not part-charge the batteries. Allow the charger to complete its cycle for every battery fitted.

Batteries are expensive to replace – it is wise to look after them. Batteries are heavy – make sure you always lift them correctly.

**Note:** Return your unserviceable batteries to your supplier or ensure they are disposed of in accordance with the environmental regulations applicable at the time.



**Warning!** If batteries are damaged or frozen they could heat up when charging and, in an extreme case, explode.

---

## User Maintenance

It is important for safety that you carry out the following checks

### Daily or Before Use

- Visually check the machine for damage.
- Visually check the tyres for damage.
- Check that the seat is secure.
- Check the armrests are secure and tight.
- Batteries should be fully charged.
- Check the operation of the brakes and if you have any concerns, contact your dealer.
- Keep your vehicle clean by using a damp cloth and soapy water – **never** use a hose.

---

### Important – Possible faults

As you get used to your vehicle you will get a feel for how it behaves. If something feels unusual, for instance the vehicle does not accelerate or brake smoothly; the vehicle tries to turn to one side, the brakes are not holding on a slope or the controller operates strangely, contact your dealer immediately and explain to the engineer exactly what the problem is.

### Disposal

Contact your dealer for advice before you consider disposing of your Powerchair. They will be aware of the environmental regulations in force at the time and will assist you to meet the applicable environmental legislation.

---

## Servicing and Maintenance

- 1. This vehicle is designed for minimum maintenance.** However it is recommended that a competent engineer service the vehicle at least once a year. If the vehicle is used constantly we recommend a twice yearly maintenance.
- 2. Ensure the engineer stamps the Service Log** (page 24) on completion for all servicing carried out on this vehicle. Keep all receipts for servicing and repairs with this handbook. This may add value when selling the vehicle.
- 3. When the vehicle is due for its service make sure you report any concerns you have,** preferably when you book the service (See points to look out for below).
- 4. On completion of the service, always test the vehicle** before the engineer leaves and make sure you are satisfied with the work carried out.

### Points to look out for:

- Are there any strange noises from the wheels or does the frame creak ?
  - Is the battery charging up correctly – is the “full” charge green light on after charging ?
  - When turning, does the Powerchair respond equally to left and right movements of the joystick ?
  - Does the Powerchair stop smoothly when the joystick is centred ?
  - Does the Powerchair tend to pull to one side ?
  - Does the speed control work ?
  - Has anything come loose ?
  - Are the handbrakes effective ? Are they worn or loose ?
  - Are there noises or rattles that were not there before ?
  - Are there any signs of damage, corrosion or cracking ?
- 

## Additional Safety Information

### Carrying Weight on the Vehicle

**Bags or Luggage:** Never carry bags (unless they are an approved accessory) behind the seat as this could result in tipping over backwards. Only carry small bags on your lap and always ensure it does not prevent you from controlling your vehicle.

**Seat Arms:** Do not carry or attach anything to the seat arms. Anything attached to the seat arms could affect stability, or interfere with the control of the vehicle.

---

## Other Precautions

**Joystick:** Do not touch the joystick when getting in or out of your Powerchair; always make sure the Powerchair is switched off.

**Modifications:** Unauthorised modifications could result in injury or permanent damage. Such modifications will invalidate any guarantees.

**Other Items:** Only fit approved products or accessories.

## Child Safety

This product is designed to be operated by adults. Children should not be allowed to tamper with the controls or play on the vehicle. Do not carry children as passengers. The product is designed for single person use only. Keep all packaging well away from children. They could be harmed.

---

## Engineer's Checklist for Powerchairs

Obtain all comments from the customer on the condition and serviceability of the Powerchair and then complete an Initial diagnostic road test. Record all defects to be corrected. Now check, test and complete the following:

- Wheel bearings for wear and lubricate
- Operation of the joystick especially to detect if there is any asymmetrical operation of the motors
- The On/Off switch for correct functioning
- The speed indicator for correct indications
- The Speed Increase and Decrease buttons for correct operation
- Wear or damage to tyres or wheels
- Handbrake effectiveness, damage, corrosion or wear
- Bodywork fixtures for damage, corrosion or cracking
- Levers and knobs securing armrests and joystick  
Do they tighten and secure properly?  
Do they need replacing?
- Joystick play, correct operation and response and carry out any necessary adjustment/replacement
- Battery contacts & signs of corrosion
- Check all cables for damage, abrasion, corrosion and that screening is intact. Replace as necessary
- Seat mounting and catch for wear or damage
- Motor brush wear/speed check
- Electromagnetic brake operation
- Freewheel operation on both motors independently
- Frame for damage or cracks
- General check for corrosion, repair or protect as necessary
- All operational controls work correctly
- Battery condition and charger operation
- Tighten all nuts & bolts
- Operation of the joystick in forward, reverse, turning, and stopping smoothly
- Correct all defects found and determine if the vehicle is roadworthy
- Final road test and operation of lights, indicators and hazard warnings
- Clean vehicle/customer road test

### Important Note for the Engineer

Enquire if the customer is satisfied with the product. Please report all points good or bad directly to: Electric Mobility 01460 258100 If you have any comments please include them.

---

# Troubleshooting Guide

This table is a guide to fault finding. The fault may be a simple fix. If you have any doubts phone your dealer.









Symptom	Solution
<ul style="list-style-type: none"><li>• <b>Powerchair does not move.</b> when power is switched on.</li></ul>	<ul style="list-style-type: none"><li>• Batteries flat - check level.</li><li>• Is the charger connected?</li><li>• Is either freewheel engaged?</li><li>• Freewheel has been selected while power is on Ensure neither freewheel is selected; switch off and on</li></ul>
<ul style="list-style-type: none"><li>• <b>Vehicle pulls to one side.</b></li></ul>	<ul style="list-style-type: none"><li>• Check for tyre damage or punctures.</li><li>• Freewheel selected on one side</li><li>• Motor failure - contact dealer.</li><li>• Binding Bearings – contact dealer</li></ul>
<ul style="list-style-type: none"><li>• <b>Vehicle behaves erratically when driven.</b> or judders or cuts out ?</li></ul>	<ul style="list-style-type: none"><li>• Possible electronic problems - contact dealer.</li></ul>
<ul style="list-style-type: none"><li>• <b>Short Range</b></li></ul>	<ul style="list-style-type: none"><li>• Check tyres for damage.</li><li>• Check batteries are fully charging.</li><li>• Check vehicle moves easily in freewheel</li></ul>

Remember, to save the batteries, the Powerchair controller has a sleep mode which is activated if the joystick is not moved for a period of time. Any button press should restore operation, but, if this does not work, switch the Powerchair off and then on again. Remember also that you may have inadvertently disabled the powerchair by locking it (see page 9). Press the power button selecting off and then press it again. The powerchair should then show the battery level and function normally. If, after several attempts it still will not operate call your dealer.

Your dealer is there to help you but they can only do this if you give them as much information as possible. Remember correct information will get the problem fixed quicker and may save you money. Phone the dealer and explain exactly what the problem is, recounting as much detail as possible including the indicated faults.

## Diagnostic Table

Your Powerchair controller provides diagnostic information by lamp indications on the Battery Level Indicator. Individual lamps will flash to indicate a fault as below:

	<b>1 Bar - Low Battery Voltage</b> The battery needs charging or there is a bad connection to the battery. Check the connections to the battery. If the connections are good, try charging the battery.
	<b>2 Bar - Left Motor Disconnected</b> The left motor has a bad connection. Check all the connections and leads between the left motor and the Power Module.
	<b>3 Bar - Left Motor Wiring Trip</b> The left motor has a short circuit to a battery. Check all the connections and leads between the left motor and the battery.
	<b>4 Bar - Right Motor Disconnected</b> The right motor has a bad connection. Check all the connections and leads between the right motor and the Power Module.
	<b>5 Bar - Right Motor Wiring Trip</b> The right motor has a short circuit to a battery. Check all the connections and leads between the right motor and the battery.
	<b>7 Bar - Possible Joystick Trip</b> A joystick trip is indicated. Make sure that the joystick is in the centre position before switching on the power.
	<b>8 Bar - Possible Control System Trip</b> A control system trip is indicated. Make sure that all connections are secure.
	<b>9 Bar - Solenoid Brake Trip</b> The parking brakes have a bad connection. Check the parking brake and motor connections. Make sure the system connections are secure.
	<b>10 Bar - High Battery Voltage</b> An excessive voltage has been applied to the Power Module. This is usually caused by a poor battery connection. Check the battery connections.

---

## Frequently Asked Questions

### ***I want to transport my vehicle in a car.***

There are various techniques. It depends on what type of vehicle you own and your physical capability. The usual way is to use specialist ramps which can be provided by your dealer. Make sure your dealer has demonstrated the easiest way of loading your powerchair into your car. See "Transporting your Powerchair" - page 15.

### ***Can I fit weatherproofing such as a canopy?***

No, the Rascal Powerchairs are too small to have canopies as they can adversely affect stability and handling.

### ***How long will my battery last ?***

This is a difficult question as it depends on many factors. The life of a battery depends upon the number of cycles the battery goes through, the peak loads and on the conditions of use. Some general advice about battery care:

- Keep it charged, and do not let the battery run completely flat.
- Ensure all you battery is fully charged at the end of the charging cycle
- Batteries may not perform as well in very cold weather.
- Change your battery if you find it is not performing as well as new.

Care can prolong the life of the batteries but remember that, in time, all batteries will fail to perform to specification.

### ***What range can I expect ?***

The generally expected range shown in the Technical Specification sheet. However, range can be affected by many things such as:

- Temperature. Cold weather can reduce the output of the batteries.
- Type of terrain. Obviously climbing hills takes more energy than driving on the flat.
- Weight of the person.
- The condition and charge of the batteries.
- Faulty or old batteries or a faulty charger

Important Rule: Always use the correct charger with the correct batteries and ensure all batteries are charged before you start out.

### ***How long should I keep my vehicle before I change it?***

It is important that the vehicle you have suits your needs and abilities. Your Rascal Powerchair should serve you well for many years but change it if at any time you feel it no longer meets your needs. Consult your dealer on the condition of your vehicle and remember vehicles of any type become more expensive to maintain the older they get.

---

## Additional Information

Owners Manual: Replacement copies are available from: Electric Mobility Euro Ltd. Canal Way, Ilminster, Somerset, TA19 9DL Telephone: 01460 258100.

If you are visually impaired, please contact the Company to discuss your requirements. However, you should not drive a vehicle in a public place if you cannot see well enough to ensure your own, and others safety.

**Important note on the BHTA Highway Code:** On page 3 of the Code under "Consider Investing in a mobile phone" Read the section of this manual under "Safety Information". If in doubt contact your dealer. For Information regarding other Electric Mobility products contact your dealer or log on to the Electric Mobility Website [www.electricmobility.co.uk](http://www.electricmobility.co.uk)

Each vehicle comes with a copy of the BHTA Highway Code. Please make sure you read it. Telephone BHTA on 02077 022 141 for a new copy.

---

## Guarantee and Warranty

### Lifetime Frame Guarantee

Electric Mobility Euro Ltd guarantees the frame of its vehicles to be free from defect in materials and workmanship under normal use as described in this document for the lifetime of the vehicle. Should a defect in materials or workmanship appear, Electric Mobility Euro Ltd, will repair, or at its option, replace the frame to the original owner.

### One Year Limited Warranty

Electric Mobility Euro Ltd warrants its products against defects in material and workmanship for a period of one year, providing the products are properly assembled, operated and maintained in accordance with the vehicle Owners Manual. This limited warranty is limited to the original purchaser. This limited warranty commences on the date of the original retail purchase or original use, whichever occurs first, providing the warranty card is fully and correctly filled out and returned to Electric Mobility Euro Ltd Customer Service Department within 15 days from receipt of product. If a defective part appears within the stated limited warranty period and the purchaser has given Electric Mobility Euro Limited immediate notice the Company will repair the part or at its option replace the part with a similar part. No allowance will be made for repairs to any equipment without the expressed written or verbal approval of Electric Mobility Euro Limited. Any description, specifications, samples, models, bulletins or similar materials used in connection with the sales of Electric Mobility Euro Limited products are for the sole purpose of identifying the equipment and are not to be construed as expressed warranties. This limited warranty applies only to the original purchaser of the equipment and is not transferable. Electric Mobility Euro Ltd shall not be liable for special, indirect or consequential damage. Electric Mobility Euro Ltd's liability on any claim of any kind including negligence for any loss or damage arising out of, connected to, or resulting from the order of the performance thereof the design, manufacture, sale, delivery, resale, direction and instructions, inspection, repair or use of any equipment covered by or furnished by, under this order, shall in no case exceed the price paid by the purchaser for the equipment. This limited warranty does not cover normal maintenance service, or periodic adjustments necessitated by use of wear. Under no circumstances will charges for labour, consequential damage or repair expense be allowed after 30 days from receipt of product.

---

## Technical Information Regarding EMI

### Important Technical Information regarding Electromagnetic Interference (EMI)

The intensity of interference from electromagnetic energy is measured in volts per meter (v/m), which refers to the strength of the electrical source (voltage) as it relates to the distance away from the object being considered (in meters). Resistance of a scooter/wheelchair to certain EMI intensity is commonly called its "immunity level". 20 volts/meter is a generally achievable and useful immunity level against interference from radio wave sources (the higher the immunity level, the greater protection).

Your powerchair has been tested and found to meet the required immunity level from Electromagnetic Interference (20v/m): the recommended density of interference from electromagnetic energy.



**Warning!** Even with the immunity level of 20 volts/meter, certain precautions must be followed to ensure your scooter/wheelchair will not be affected by outside electromagnetic sources.

- Do not operate devices such as CB radios or mobile phones while the vehicle is switched on.
  - Avoid getting close to transmitter masts, such as television and radio masts.
  - Note you may experience interference when close to ambulance or fire stations.
- If your vehicle starts to operate by itself switch it off and report this to your Dealer.



## Technical Specification - Rascal Powerchair P200

Powerchair type Class	Class A, B or C	Class B
Department of Transport Class	Class 1 2 or 3	Class 2
Overall dimensions fully assembled	length x width x height mm (in)	1090 (43) x 670 (26) x 1000 (39)
Overall dimensions seat folded	length x width x height mm (in)	1090 (43) x 670 (26) x 760 (30)
Maximum carrying capacity - not to be exceeded	kg (lb)	136 (300)
Mass (weight) including batteries	kg (lb)	90 (198)
Battery voltage and capacity	volts and ampere hours	12V 50Ah x 2
Mass (weight) of batteries	kg (lb)	2 x 18.2 (40)
Type of seat		Non detachable, integral to powerchair
Seat width	mm (in)	457 (18)
Wheel size	front/rear mm (in)	210 (8.25) / 355 (14)
Type of tyres	type	Solid
Maximum speed	km/h (m.p.h.)	6.2 (4)
Minimum braking distance from maximum speed	m (ft)	1.2 (4)
Range on full charge and flat ground	km (miles)	Up to 26 (16.2)
The turn-around width	m (ft)	1.30 (4' 3")
The maximum safe slope	degrees of slope	8° - Do not exceed the powerchair may topple
The maximum climbing ability facing upwards	degrees of slope	8°
Ground clearance	mm (in)	50 (2)
Maximum obstacle climbing ability	mm (in)	50 (2)
Maximum safe descendable kerb height	mm (in)	50 (2)

---

# Service Log

**Notice for the Service Engineer.**

Please make sure this part is stamped and dated after each service.

**Dealer stamp - 1st Service**



**Dealer stamp - 2nd Service**



**Dealer stamp - 3rd Service**

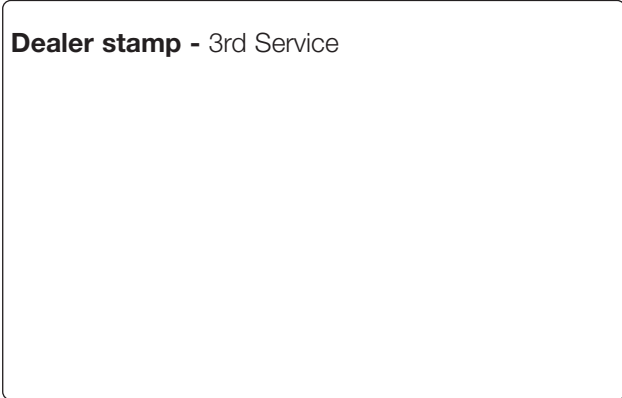

**Dealer stamp - 4th Service**

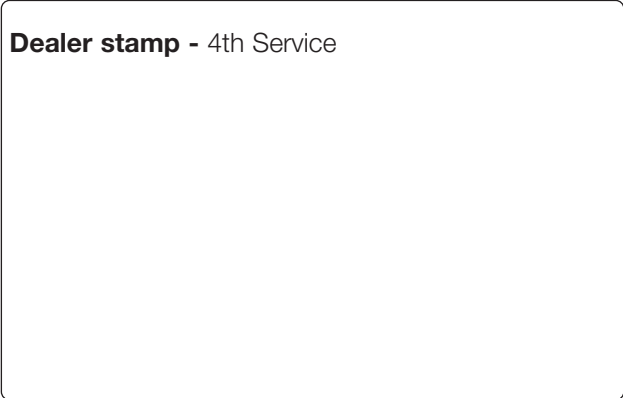

**Dealer stamp - 5th Service**

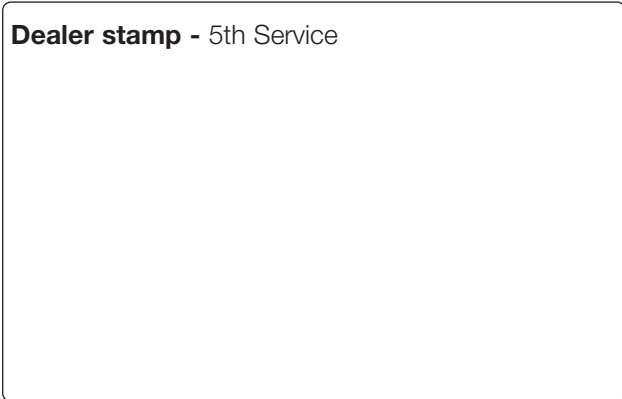

**Dealer stamp - 6th Service**

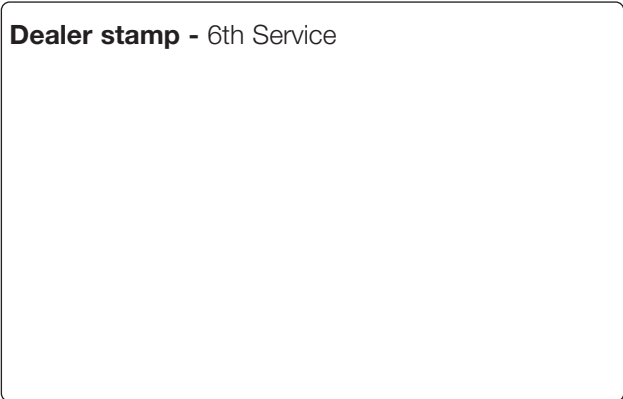

**Dealer stamp - 7th Service**



**Dealer stamp - 8th Service**



# Brochure Request

Do you have a friend or colleague that would be interested in an Electric Mobility product?  
If so cut out this coupon and send it to the address shown on the back of the manual.

My Dealer's Company name is:	
<hr/>	
<input type="checkbox"/>	Please can I have a free no-obligation home demonstration.
<input type="checkbox"/>	Please send me a brochure of the range of products.
My friend's name is:	
<hr/>	
My friend's address is:	
<hr/>	
<hr/>	
County:	Postcode:
<hr/>	
My friend's telephone number is:	
<hr/>	

If you are visually impaired, please contact the Company to discuss your requirements. However, you should not drive a vehicle in a public place if you cannot see well enough to ensure your own, and others safety.

Postage will be paid by: Electric Mobility Euro Ltd., FREEPOST (SWBI 1045), Ilminster, Somerset, TA19 9ZA



# Dealer Information - Warranty Card

This section is to be filled out by the Dealer and sent to Electric Mobility Euro Ltd.

Dealer:	
<hr/>	
Product Description:	
<hr/>	
Serial No.:	Invoice No.:
<hr/>	
Customer Name & Address:	
<hr/>	
<hr/>	
County:	Postcode:
<hr/>	
Telephone No.:	
<hr/>	
Date received at Dealers:	
<hr/>	

Postage will be paid by: Electric Mobility Euro Ltd., FREEPOST (SWBI 1045), Ilminster, Somerset, TA19 9ZA



**Electric Mobility Euro Ltd.,  
FREEPOST (SWBI 1045),  
Ilminster,  
Somerset,  
TA19 9ZA**

**Electric Mobility Euro Ltd.,  
FREEPOST (SWBI 1045),  
Ilminster,  
Somerset,  
TA19 9ZA**

---

## Notes

---

## Rascal Powerchair Model P200

Manufactured by



**Electric Mobility Euro Limited**, Canal Way, Ilminster, Somerset TA19 9DL  
Telephone: 01460 258100 [www.electricmobility.co.uk](http://www.electricmobility.co.uk)

E. and O.E. Issue 1: 05/09